

# SLIM QUBE SSQUHT

## Installation & Maintenance

## Installation Instructions

### 1.0 General

- 1.1 It is important these Installation and Maintenance Instructions are fully adhered to.
- 1.2 Full details of the unit supplied are shown on the product nameplate. If in doubt about any detail contact Elta Fans Ltd or its agents for clarification.
- 1.3 All electrical installation must be carried out by suitably qualified and competent personnel in accordance with all current statutory requirements.
- 1.4 These instructions cover only the Elta Fans Ltd product and do not include the supply or installation of any safety equipment that may be required e.g. adequate guarding or protection from rotating parts and proper electrical isolation.
- 1.5 Any declarations made by Elta Fans Ltd about product installation and safety, are dependent on the fan equipment being used within installations which themselves meet the requirements of the relevant Standards and Directives of your region.
- 1.6 Electrical Installation shall comply with BS7671 and EN60079-0.
- 1.7 The fan must be protected to IP20 as described in EN60529 to protect against foreign particles.
- 1.8 The hazardous area in which the fan may be installed is defined by the ATEX code, which can be found on the fan label, drawing and Certificate of Conformity.
- 1.9 The fan is designed for use in an ambient temperature of -20°C up to +40°C.
- 1.10 Zone separation between the inside and outside of the fan can be no more than one zone (e.g. Zone 1 inside the fan, Zone 2 outside the fan).- Except when installed using a flexible duct connection where there is no Zone separation.  
Note:- NOT SUITABLE FOR 'Zone 0' USE!
- 1.11 The ignition minimizing properties of the fan and its accessories can only be retained if routine inspections, services and cleaning are carried out.
- 1.12 The installer should provide easy access to the fan to facilitate future maintenance.
- 1.13 The installer should ensure the fan is adequately supported.
- 1.14 This product is not intended for use by persons (including children) with reduced physical, sensory or mental capabilities, or lack of experience and knowledge, unless they have been given supervision or instruction concerning use of the product by a person responsible for their safety.  
Children should be supervised to ensure that they do not play with the product
- 1.15 At end-of-life, the unit must be disposed of in an environmentally friendly manner by suitably qualified and competent personnel in accordance with the requirements of applicable Standards and Directives.

### 2.0 Installation

**WARNING** – The fan must be isolated from the power supply during installation and maintenance. The fan must be earthed in accordance with the local regulations.

- 2.1 Upon receipt, the fan equipment should be visually inspected to check for any damage. Ensure that the impeller is free to rotate.
- 2.2 If there are any queries concerning the fan equipment, Elta Fans Ltd should be contacted prior to the installation.
- 2.3 The fan must be securely mounted and the panels adjusted to suit the desired position to suit the application.
- 2.4 Check the details on the motor/fan rating plate to ensure that the correct power supply (voltage, frequency and phase) is available. An incorrect power supply will lead to permanent damage to the motor.
- 2.5 Refer to the appropriate wiring diagram. Ensure that all earth connections are made.
- 2.6 Means for electrical disconnection must be incorporated in the wiring installation in accordance with the relevant wiring and electrical regulations.
- 2.7 Precaution must be taken to locate the exhaust discharge terminal so as to avoid the backflow of gases into the room from the open flue of gas or other fuel burning appliances.

### 3.0 Storage

- 3.1 The storage place must be vibration free, clean, dry and not subject to extreme temperature variations.
- 3.2 When storing for prolonged periods, whereby non rotation of motor occurs, we recommend electrical and bearing inspection, as they may have incurred damage or require possible re-lubrication.

**WARNING** – Elta Fans Ltd should be consulted in instances where speed controllers or inverter devices are to be used.

### 4.0 Start Up

- 4.1 Before power is supplied to the unit, check that the wiring is correct as per the fan connection diagram.
- 4.2 At initial start-up, check that impeller rotation and airflow direction is correct.
- 4.3 Check that the motor amperage draw does not exceed the nameplate rating.

### 5.0 Fan Maintenance

- 5.1 Inspection of the fan at least once every 12 months is recommended to ensure that the motor, fan blades, and supporting guards, are clean. Any build up of dust and deposits on the blades or guards should be removed using a non-abrasive cleaner.
- 5.2 All fastenings should be checked for tightness. In addition, all rotating items should be checked.
- 5.3 Bearings are of the 'sealed for life' type and will not need a detailed inspection.
- 5.4 The range has an easily removable motor/impeller assembly, and panel arrangement fixed to Multi- thread "U" nuts, ideal for frequent cleaning.

# SLIM QUBE SSQUHT



## Installation Instructions

**Table 1: Operational Maintenance**

Activity	Frequency
Inspect AV mounts for Corrosion or “Sag”	6 months
Check earth bonding	6 months
Dampers check rubber stops and grease (lithium based) pivot points, by removing plastic caps	Yearly
Check fixings tightness and conditions of brass track and rivets	26,000 hours / 3 years
Inspect and clean impeller	26,000 hours / 3 years
Remove dirt from motor cooling fins	26,000 hours / 3 years
Check operation of anti-condensation heaters	26,000 hours / 3 years
Check for even tip clearance between impeller and casing – For ATEX 10% of motor shaft diameter with 2mm minimum and 13mm maximum.	26,000 hours / 3 years
Check motor Amps	26,000 hours / 3 years
Any corrosion - treat with suitable chemicals	26,000 hours / 3 years
Check casing seals	26,000 hours / 3 years

**Table 2: Terminal Box Maintenance**

Activity	Frequency
Check that lid seal is in place and not damaged	Each time the enclosure is opened
Check that lid fixing screws are in place and secured	Each time the enclosure is closed
Check that the mounting bolts are tight and free from corrosion	Annually
Check security of all cable glands	Annually
Check that all screw clamps terminals are secure	Annually and each time enclosure is opened
Check enclosure for damage	Annually

### 6.0 Guarantee

Elta Fans Ltd will, free of charge, within a period of 1 year from the date of dispatch from their works, repair or at its option replace any goods which are provided to have defects as a result of defective materials or workmanship. The goods MUST be returned to Elta Fans Ltd carriage paid for examination.

### 7.0 Wiring

**WARNING** – Correct rotation must be ensured as Air flow direction will be correct even if the impeller is rotating in the wrong direction. Incorrect direction of rotation will result in lower air volumes, increased noise and higher electrical current, which will harm the motor.

# SLIM QUBE SSQUHT



## Wiring Diagrams

Please use the table(s) below to match up the product code and the wiring diagram number.

### Three Phase 380V - 415V / 50Hz

Page No.	Product Code	Wiring Diagram No.
5	<a href="#">SSQU1/4-3HT</a>	152-600
5	<a href="#">SSQU2/4-3HT</a>	152-600
5	<a href="#">SSQU22/4-3HT</a>	152-600
5	<a href="#">SSQU3/4-3HT</a>	152-600
5	<a href="#">SSQU23/4-3HT</a>	152-600
5	<a href="#">SSQU4/4-3HT</a>	152-600
6	<a href="#">SSQU24/4-3BHT</a>	152-601
6	<a href="#">SSQU4/4-3BHT</a>	152-601
5	<a href="#">SSQU4/6-3HT</a>	152-600

# 152-600

## Wiring Diagrams

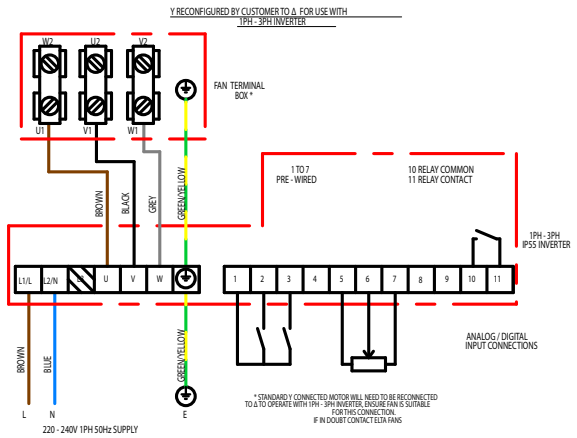
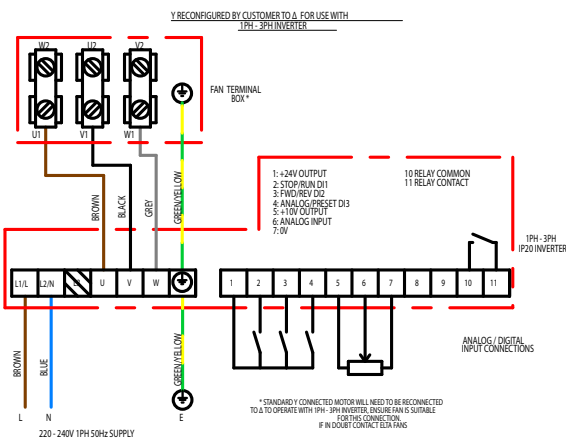
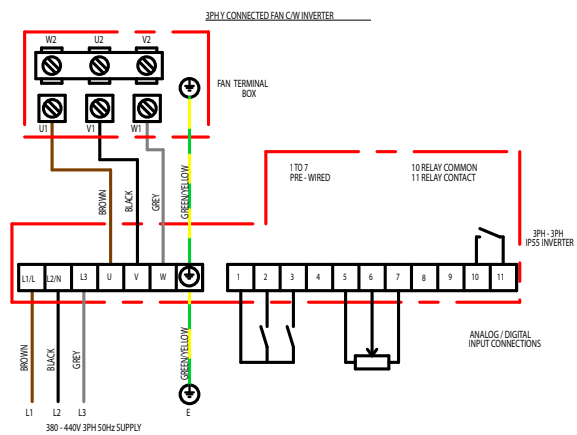
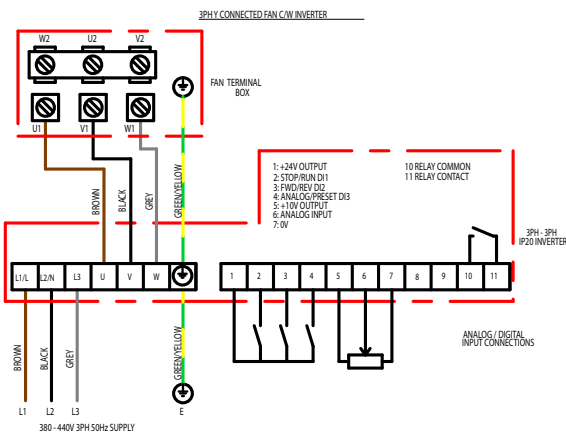
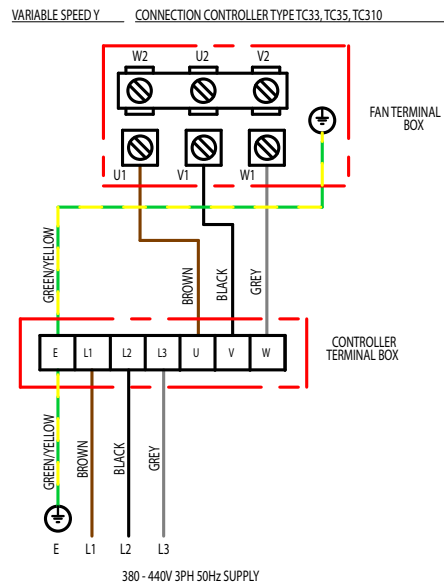
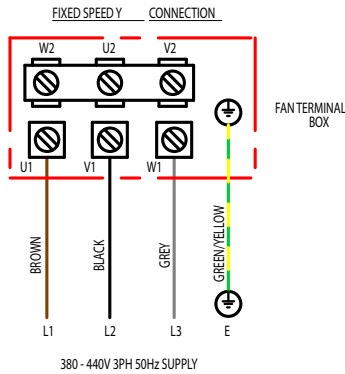

All wiring and control equipment must comply to the latest IEE regulations, in particular part 552-01-02/03.  
 MK-152-600 Issue B: 29.04.2015  
 Check the individual product accessories table for fan controller compatibility.

# 152-601

## Wiring Diagrams

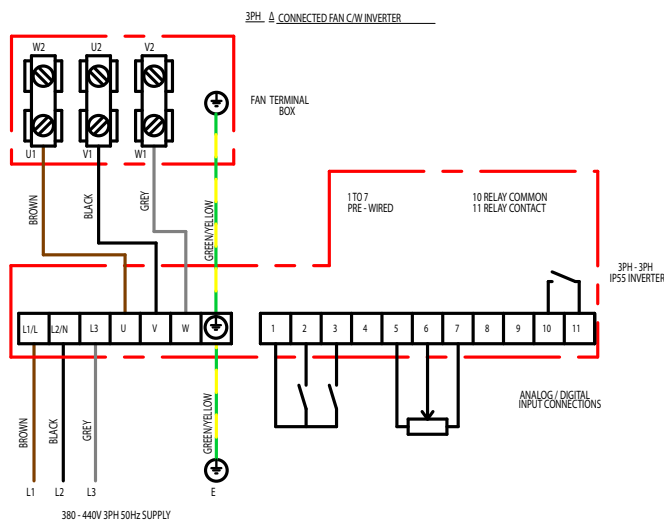
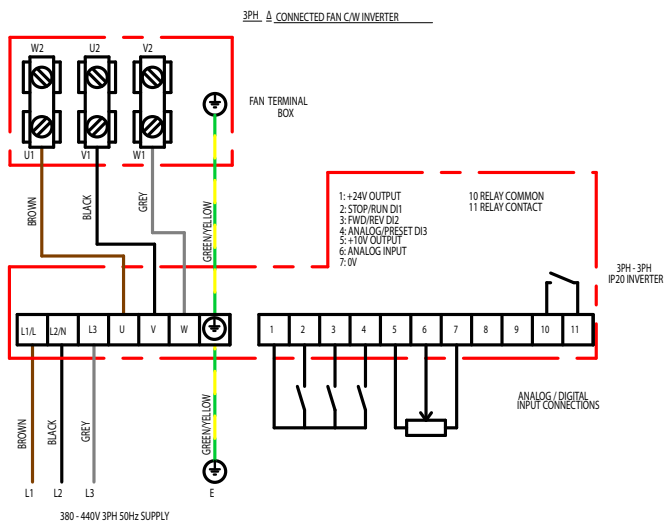
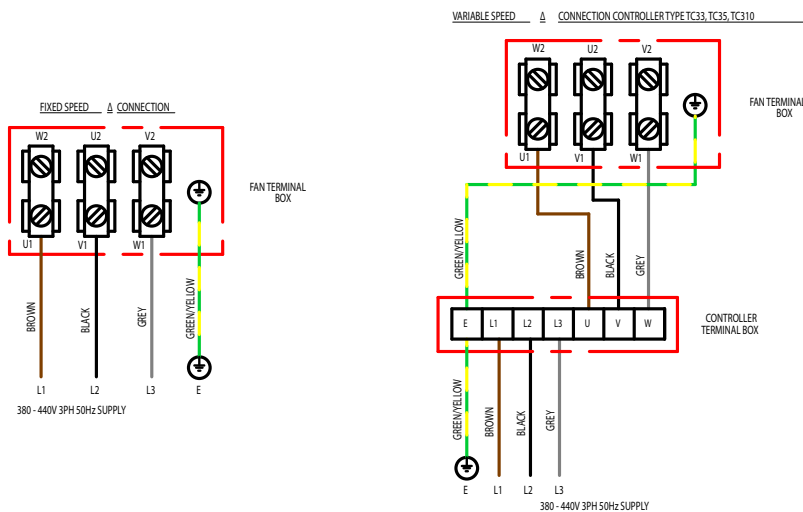

All wiring and control equipment must comply to the latest IEE regulations, in particular part 552-01-02/03.

MK-152-601 Issue B: 15.07.2013

Check the individual product accessories table for fan controller compatibility.



## Building Services

Tel **+44 (0) 1384 275800**  
Fax **+44 (0) 1384 275810**  
Email **bs@eltafans.co.uk**

46 Third Avenue, Pensnett Trading Estate, Kingswinford,  
West Midlands, DY6 7US United Kingdom

## Applied Technology & Building Services Export

Tel **+44 (0) 1489 566500**  
Fax **+44 (0) 1489 566555**  
Email **at@eltafans.co.uk / export@eltafans.co.uk**

17 Barnes Wallis Road, Segensworth East Industrial Estate,  
Fareham, Hampshire, PO15 5TT United Kingdom

**eltafans.com**

535-IOM0034 Issue C



BS EN ISO 9001:2015 FM 556465

