



TWINFLOW STDR

Installation & Maintenance

TWINFLOW STDR



Installation Instructions

1.0 General

- 1.1 It is important these Installation and Maintenance Instructions are fully adhered to.
- 1.2 Full details of the unit supplied are shown on the product nameplate. If in doubt about any detail contact Elta Fans Ltd or its agents for clarification.
- 1.3 All electrical installation must be carried out by suitably qualified and competent personnel in accordance with all current statutory requirements.
- 1.4 These instructions cover only the Elta Fans Ltd product and do not include the supply or installation of any safety equipment that may be required e.g. adequate guarding or protection from rotating parts and proper electrical isolation.
- 1.5 Any declarations made by Elta Fans Ltd about product installation and safety, are dependant on the fan equipment being used within installations which themselves meet the requirements of the relevant Standards and Directives of your region.
- 1.6 The fan is designed for use in an ambient temperature of -20°C up to +60°C and up to 95% relative humidity. The fan is not suitable for corrosive or explosive atmospheres.
- 1.7 The installer should provide easy access to the fan to facilitate future maintenance.
- 1.8 The installer should ensure the fan is adequately supported.
- 1.9 This product is not intended for use by persons (including children) with reduced physical, sensory or mental capabilities, or lack of experience and knowledge, unless they have been given supervision or instruction concerning use of the product by a person responsible for their safety.
Children should be supervised to ensure that they do not play with the product.
- 1.10 At end-of-life, the unit must be disposed of in an environmentally friendly manner by suitably qualified and competent personnel in accordance with the requirements of applicable Standards and Directive

2.0 Installation

WARNING – The fan must be isolated from the power supply during installation and maintenance. The fan must be earthed in accordance with the local regulations.

- 2.1 Upon receipt, the fan equipment should be visually inspected to check for any damage. Ensure that the impeller is free to rotate.
- 2.2 If there are any queries concerning the fan equipment, Elta Fans Ltd should be contacted prior to the installation.
- 2.3 The fan must be securely mounted in the desired position to suit the application.
The fan is only suitable for horizontal mounting.
- 2.4 Check the details on the motor rating plate to ensure that the correct power supply (voltage, frequency and phase) is available.
An incorrect power supply will lead to permanent damage to the fan motor.
- 2.5 Refer to the appropriate wiring diagram. Ensure that all earth connections are made.
- 2.6 Means for electrical disconnection must be incorporated in the wiring installation in accordance with the relevant wiring and electrical regulations.
- 2.7 Precaution must be taken to locate the exhaust discharge terminal so as to avoid the backflow of gases into the room from the open flue of gas or other fuel burning appliances.

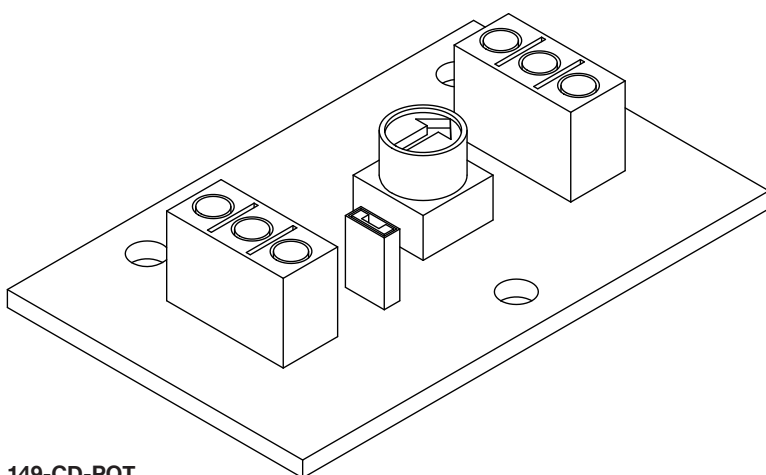

149-CD-POT

Level / Speed	OHMS (Ω)
10	10 (Ω)
9	9 (Ω)
8	8 (Ω)
7	7 (Ω)
6	6 (Ω)
5	5 (Ω)
4	4 (Ω)
3	3 (Ω)
2	1.5 (Ω)
1	500 (Ω)
0	1 (Ω)

Please note: This is an estimated adjustment guide

TWINFLOW STDR



Installation Instructions

149-CD-POT

The 149-CD-POT is a commissioning device designed to be used with our EC range of fans.

This device will be as standard with our box fan range from May 2018.

The device will allow the installer to set the maximum operating speed of the fan that it is connected to.

The installer or commissioning engineer can adjust the fan speed using the potentiometer built onto the 149-CD-POT board.

This potentiometer can either be used for single speed adjustment or to set a maximum speed for the fan to operate at when an external control source is used.

If external speed control is required, the jumper connection next to the potentiometer on the board would need to be removed, the installer can then connect to ST1 (using the diagram provided).

When an external speed control is fitted, the maximum speed setting available to the external control is limited by the potentiometer setting of the commissioning device.

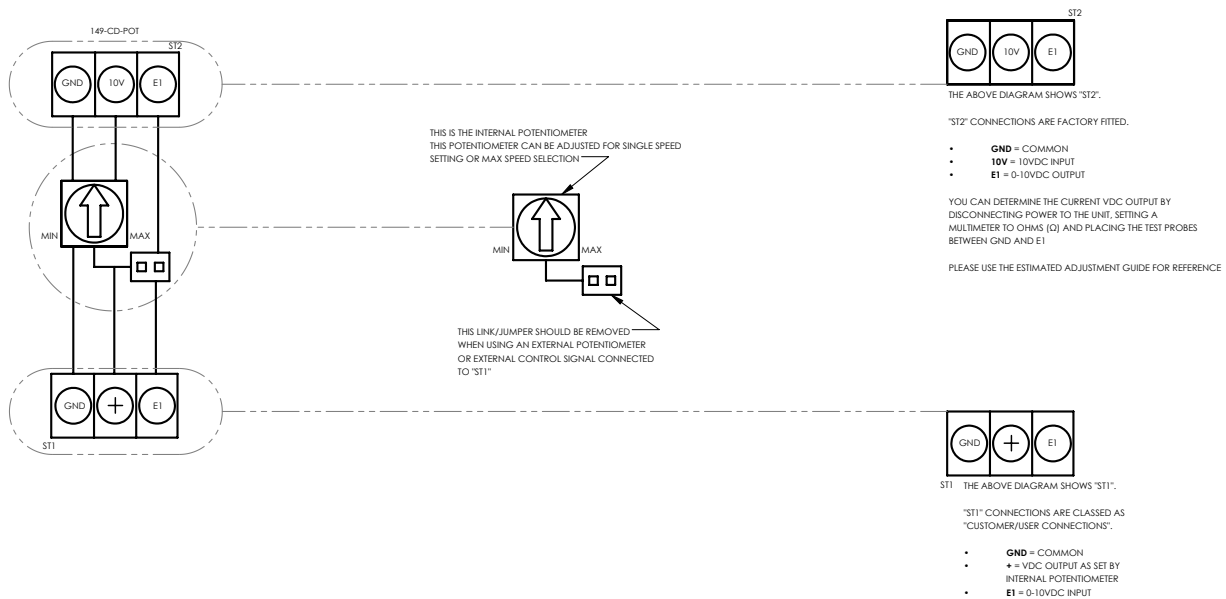

All wiring and control equipment must comply to the latest IEE regulations, in particular part 552-01-02/03.

149-CD-POT Issue A: 10.07.2018

Check the individual product accessories table for fan controller compatibility.

3.0 Start Up

3.1 Before power is supplied to the unit, check that the wiring is correct as per the fan connection diagram.

3.2 At initial start-up, check that impeller rotation and airflow direction is correct.

3.3 Check that the motor amperage draw does not exceed the nameplate rating.

4.0 Fan Maintenance

4.1 Inspection of the fan at least once every 12 months is recommended to ensure that the motor, fan blades, and supporting guards, are clean. Any build up of dust and deposits on the blades or guards should be removed using a non-abrasive cleaner.

4.2 All fastenings should be checked for tightness. In addition, all rotating items should be checked.

4.3 Bearings are of the 'sealed for life' type and will not need a detailed inspection.

WARNING – STDR fans are fitted with an auto-reset thermal contact which switches the fan off in the event of a fault condition.

Once the motor cools down the fan may start unexpectedly.

Fuses /circuit breakers are used to provide short circuit protection only. A starter panel with overload protection should be used to protect the motor.

Only a suitably qualified and competent person may carry out maintenance after the electrical supply has been isolated.

TWINFLOW STDR

Installation Instructions

Table 1: Operational Maintenance

Activity	Frequency
Inspect AV mounts for Corrosion or “Sag”	6 months
Check earth bonding	6 months
Dampers check rubber stops and grease (lithium based) pivot points, by removing plastic caps	Yearly
Check fixings tightness and conditions of brass track and rivets	26,000 hours / 3 years
Inspect and clean impeller	26,000 hours / 3 years
Remove dirt from motor cooling fins	26,000 hours / 3 years
Check operation of anti-condensation heaters	26,000 hours / 3 years
Check for even tip clearance between impeller and casing – For ATEX 10% of motor shaft diameter with 2mm minimum and 13mm maximum.	26,000 hours / 3 years
Check motor Amps	26,000 hours / 3 years
Any corrosion - treat with suitable chemicals	26,000 hours / 3 years
Check casing seals	26,000 hours / 3 years

Table 2: Terminal Box Maintenance

Activity	Frequency
Check that lid seal is in place and not damaged	Each time the enclosure is opened
Check that lid fixing screws are in place and secured	Each time the enclosure is closed
Check that the mounting bolts are tight and free from corrosion	Annually
Check security of all cable glands	Annually
Check that all screw clamps terminals are secure	Annually and each time enclosure is opened
Check enclosure for damage	Annually

5.0 Storage

- 5.1 If the fan is not to be used immediately then it should be stored in a clean, dry, vibration free and lockable location.
- 5.2 The impeller must be spun by hand (ensuring that it does not come to rest in the same position) on a monthly basis to prevent hardening of the grease and possible damage to the bearings.
- 5.3 All items to be stored on pallets that afford adequate protection from damage, dust and high humidity.
- 5.4 If storage periods of longer than 1 month are anticipated then Elta (or their Agent) should be contacted prior to storage taking place, to ensure the storage area provisions will not be detrimental to the well being of Elta products.

6.0 Guarantee

Elta Fans Ltd will, free of charge, within a period of 1 year from the date of dispatch from their works, repair or at its option replace any goods which are proved to have defects as a result of defective materials or workmanship. The goods MUST be returned to Elta Fans Ltd carriage paid for examination.

TWINFLOW STDR

Wiring Diagrams

Please use the table(s) below to match up the product code and the wiring diagram number.



Single Phase 200V - 277V / 50Hz or 60Hz

Page No.	Product Code	Wiring Diagram No.
6	STDR315-1EC	152-02298951-CD
7	STDR400-1EC	152-2MOEA03K1-CD
7	STDR500-1EC	152-2MOEA03K1-CD

Three Phase 380V - 480V / 50Hz or 60Hz

Page No.	Product Code	Wiring Diagram No.
8	STDR500-3EC	152-2MOEA03K3-CD

152-02298951-CD



Wiring Diagrams

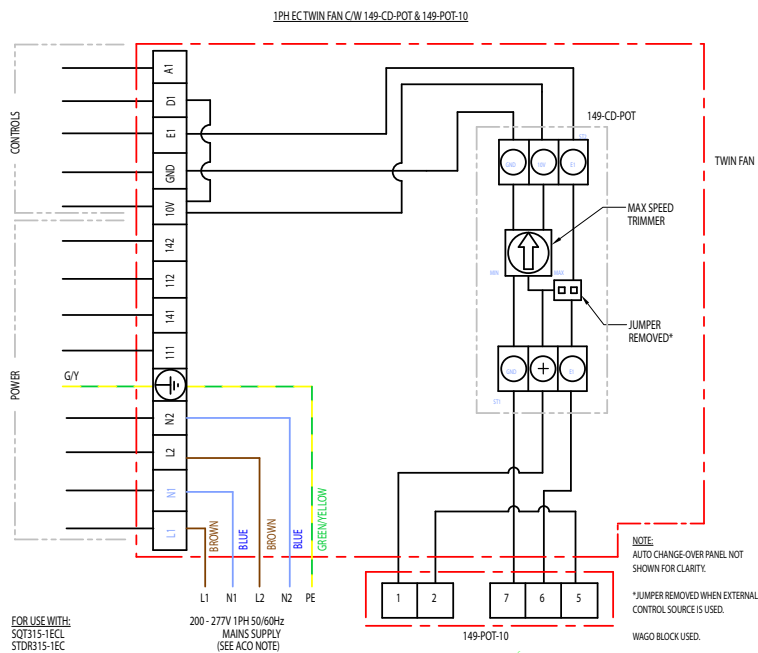
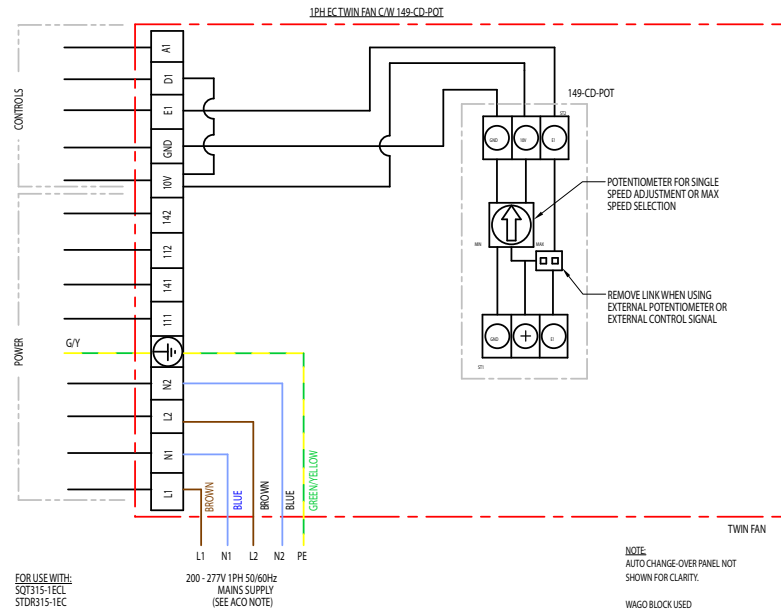

All wiring and control equipment must comply to the latest IEE regulations, in particular part 552-01-02/03.
MK-152-00298951-CD Issue B: 20.06.2018
Check the individual product accessories table for fan controller compatibility.

152-2MOEA03K1-CD



Wiring Diagrams

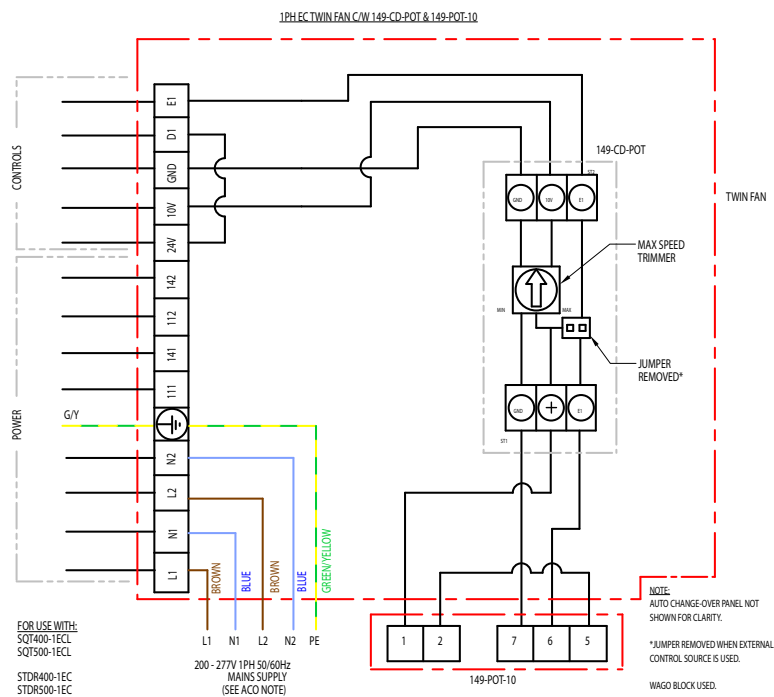
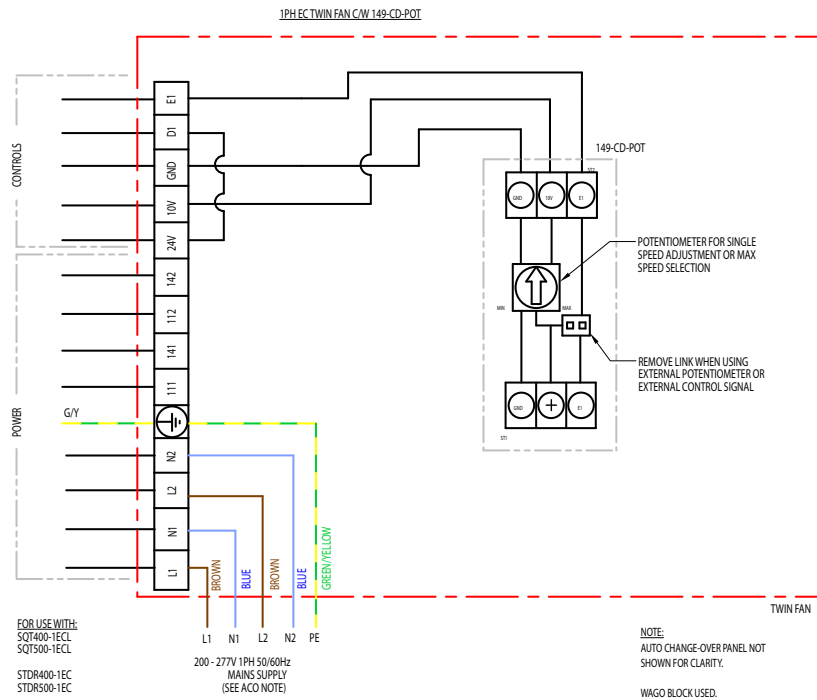

All wiring and control equipment must comply to the latest IEE regulations, in particular part 552-01-02/03.

MK-152-2MOEA03K1-CD Issue C: 25.03.2021

Check the individual product accessories table for fan controller compatibility.

Building Services

Tel **+44 (0) 1384 275800**
Fax **+44 (0) 1384 275810**
Email **bs@eltafans.co.uk**

46 Third Avenue, Pensnett Trading Estate, Kingswinford,
West Midlands, DY6 7US United Kingdom

Applied Technology & Building Services Export

Tel **+44 (0) 1489 566500**
Fax **+44 (0) 1489 566555**
Email **at@eltafans.co.uk / export@eltafans.co.uk**

17 Barnes Wallis Road, Segensworth East Industrial Estate,
Fareham, Hampshire, PO15 5TT United Kingdom

eltafans.com

535-IOM0039 Issue F



BS EN ISO 9001:2015 FM 556465

