



# HPFA

Pedestal  
Circulating Fan

# HPFA

## Product Overview

- Air volume flow rates up to 3.83 m<sup>3</sup>/s
- Three speed settings
- Adjustable height
- Suitable for operating temperatures up to +45°C
- Smooth oscillation through 90° arc
- 30° Adjustable airflow direction
- Available in **AC**

**The HPFA Pedestal Fan is a floor mounted air circulation fan designed to provide powerful, effective positive air movement, improving the environmental conditions in a wide variety of industrial, commercial and residential building services applications.**

### Construction

The all metal fan casing provides a long lasting robust construction. Guards are black painted wire with additional radial supports to provide increased stiffness. The HPFA is supported by a heavy duty cast iron base which provides added sturdiness and durability for the unit.

### Warranty

Each HPFA has a 12 month warranty.

### Motors

Motors are three speed induction, with sealed for life bearings, suitable for operating temperatures up to +45°C.

### Impeller

The fan blades are constructed from high quality aluminium, fully balanced, with epoxy powder coated black finish for aesthetic appearance.

### Electrical

All units are suitable for Single Phase 220V to 240V 50Hz operation.

### Typical Applications

- Industrial Warehousing
- Gymnasiums
- Factories
- Marquees and Workshops



### Contents

Page	Information
3	Performance SFP & Electrical Data
4	Dimensional Data
5	Notes

### Product Coding

Code	Reference
<b>HPFA</b>	Product Range
<b>650</b>	Diameter
e.g.	<b>HPFA650</b>

## Performance, SFP & Electrical Data

**Single Phase** 220V to 240V / 50Hz

Product Code	Speed r/min	Air Delivery Max m <sup>3</sup> /s	Electrical Data		dBA @ 3m
			Power W	FLC Amps	
HPFA650	890	1.830	130	0.56	46
	1050	2.830	148	0.62	50
	1380	3.830	170	0.80	59

## Dimensional Data

### Single Phase

Product Code	A	B	C	D (min-max)	E	Weight kg
HPFA650	360	690	30°	1460-1860	525	23

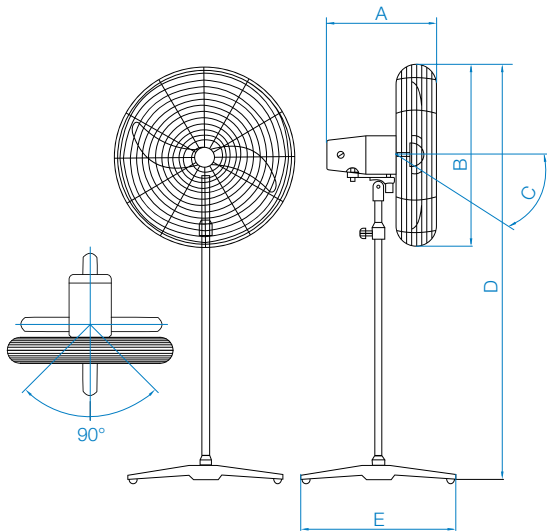

Dimensions are in mm.







## Building Services

Tel **+44 (0) 1384 275800**  
Fax **+44 (0) 1384 275810**  
Email **info@eltafans.co.uk**

46 Third Avenue, Pensnett Trading Estate, Kingswinford,  
West Midlands, DY6 7US United Kingdom

## Applied Technology & Building Services Export

Tel **+44 (0) 1489 566500**  
Fax **+44 (0) 1489 566555**  
Email **at@eltafans.co.uk / export@eltafans.co.uk**

17 Barnes Wallis Road, Segensworth East Industrial Estate,  
Fareham, Hampshire, PO15 5ST United Kingdom

**eltafans.com**

HPFA-11-2018 Issue A



BS EN ISO 9001:2015 FM 556465

