

Installation manual

ARCO D - Axial fan

Read this manual carefully before using the product and keep it in a safe place for reference.

This product was constructed up to standard and in compliance with regulations relating to electrical equipment and must be installed by technically qualified personnel.

The manufacturer assumes no responsibility for damage to persons or property resulting from failure to observe the regulations contained in this booklet.

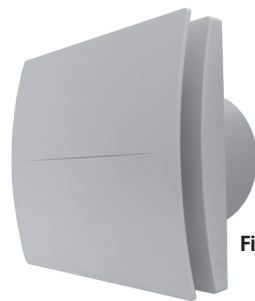

Fig. 1

PRECAUTIONS FOR INSTALLATION, USE AND MAINTENANCE

- The device should not be used for applications other than those specified in this manual.
- After removing the product from its packaging, verify its condition. In case of doubt, contact a qualified technician. Do not leave packaging within the reach of small children or people with disabilities.
- Do not touch the appliance with wet or damp hands/feet.
- This appliance can be used by children aged from 8 years and above and persons with reduced physical, sensory or mental capabilities or lack of experience and knowledge if they have been given supervision or instruction concerning use of the appliance in a safe way and understand the hazards involved. Children shall not play with the appliance. Cleaning and user maintenance shall not be made by children without supervision.
- Do not use the product in the presence of flammable vapours, such as alcohol, insecticides, gasoline, etc...
- If any abnormalities in operation are detected, disconnect the device from the mains supply and contact a qualified technician immediately. Use original spare parts only for repairs.
- The electrical system to which the device is connected must comply with regulations.
- Before connecting the product to the power supply or the power outlet, ensure that:
 - the data plate (voltage and frequency) correspond to those of the electrical mains
 - the electrical power supply/socket is adequate for maximum device power. If not, contact a qualified technician.
- The device should not be used as an activator for water heaters, stoves, etc., nor should it discharge into hot air/fume vent ducts deriving from any type of combustion unit. It must expel air outside via its own special duct.
- Operating temperature: 0°C up to +50°C.
- The device is designed to extract clean air only, i.e. without grease, soot, chemical or corrosive agents, or flammable or explosive mixtures.
- Do not leave the device exposed to atmospheric agents (rain, sun, snow, etc.).
- Do not immerse the device or its parts in water or other liquids.
- Turn off the main switch whenever a malfunction is detected or when cleaning.
- For installation an omnipolar switch should be incorporated in the fixed wiring, in accordance with the wiring regulations, to provide a full disconnection under overvoltage category III conditions (contact opening distance equal to or greater than 3mm).
- If the supply cord is damaged, it must be replaced by the manufacturer, its service agent

or similarly qualified persons in order to avoid a hazard.

- Do not obstruct the fan or exhaust grille to ensure optimum air passage.
- Ensure adequate air return into the room in compliance with existing regulations in order to ensure proper device operation.
- If the environment in which the product is installed also houses a fuel-operating device (water heater, methane stove etc., that is not a “sealed chamber” type), it is essential to ensure adequate air intake, to ensure good combustion and proper equipment operation.
- Install the product so that the impeller is not accessible from the air outlet side as verified by contact with the Test Finger (test probe “B” of the norm EN61032) in compliance with the current safety regulations.

• Ceiling installation

In order to guarantee the IPX4 degree of protection against moisture in case of ceiling installation, use the appropriate ceiling mount kit, which is not included. Use only the rear entry hole for supply cables. If there is a possibility of condensation along the air discharge duct, provide a drainage system to prevent condensation from discharging into the environment through the fan.

Attention: do not mount the product on the ceiling without this kit.

• Window installation

In case of window installation it is necessary to use the appropriate window kit, which is not included.

Attention: do not mount the product on the window without this kit.

INTRODUCTION

ARCO D (Fig. 1) is an axial fan designed to ensure air extraction in small/medium-sized rooms such as bathrooms, toilets and kitchens.

Suitable for air discharge directly to the outside or in the presence of short linear duct (less than 1.5m). Wall, ceiling or window installation (Fig. 2).

TECHNICAL SPECIFICATIONS

- Material: high quality, impact and UV-resistant ABS colour RAL 9010.
- Design front cover removable for cleaning without the use of tools.
- Rear reinforcement ring to prevent spigot deformation during installation.
- High efficiency aerodynamic fan with “winglet” blades to optimise quietness and efficiency.
- Single phase induction motor with integral thermal protection.
- Integral back draught shutters.
- Motor mounted on ball bearings that guarantee a longer product life cycle (30.000h) and suitable for cold climates.
- The fan is double insulated: no earth connection is required.
- Suitable for continuous or intermittent operation.
- IPX4 degree of protection.
- Power supply 220V to 240V~ 50/60Hz.

Model	Airflow (max)		Static pressure Pa max	Power W max	Sound pressure dB(A) @3m
	L/s	m³/h			
ARCO D 100	23.1	83	27	8	32
ARCO D 125	39.0	140	40	14	41
ARCO D 150	70.7	253	51	24	48

VERSIONS

STANDARD

The fan is operated using a separate ON/OFF switch or via a light switch (Fig. 14A).

PULL CORD

The fan is operated using an integrated pull cord switch (Fig.14C).

WITH TIMER (over-run)

The fan is provided with a timer circuit which is adjustable from aprox. 1 minute to 25 minutes via trimmer (Fig. 15B).

Operation: connected according to the diagram in Fig. 14B, after the light is switched on, the fan activates with a delay of max 1.5 seconds. After the light is switched off, the fan continues to function for a pre-set period of time.

WITH HUMIDISTAT & TIMER

The fan is equipped with a humidity detector, whose threshold is adjustable from 50% to 95% Relative Humidity, and with a timer which is adjustable from aprox. 1 minute to 25 minutes via corresponding trimmer (Fig. 15D).

Turn the trimmer HY completely clockwise and the humidistat function is deactivated.

Automatic humidistat operation: connected according to the diagram in Fig. 14D, when the percentage of Relative Humidity exceeds the pre-set intervention threshold, the fan starts up automatically. When the percentage of Relative Humidity goes below the threshold, the fan continues to function for a pre-set period of time.

Operation with switch connection: connected according to the diagram in Fig. 14D, after the light is switched on, the fan activates with a delay of aprox. 1.5 seconds. After it is switched off, the fan continues to function for a pre-set period of time.

Operation via pull cord switch (HTC version): connected according to the diagram in Fig. 15C. By switching on, the fan activates with a delay of aprox. 1.5 seconds. After switching off, the fan continues to function for a pre-set period of time

Attention: When the relative humidity level is higher than the pre-set threshold, automatic operation with humidistat has priority over manual operation, or rather the fan cannot be stopped via switch.

STANDARD CONFORMITY

2014/35/EU Low Voltage Directive (LVD)

2014/30/EU Electromagnetic Compatibility (EMC),

in conformity with the following standards:

Electrical Safety: EN60335-1(2012)+A11+A13; EN 60335-2-80(2003)+A1+A2.

Electromagnetic Compatibility: EN 55014-1(2017); EN 55014-2(2015); EN 61000-3-2(2014); EN 61000-3-3(2013).

INSTALLATION (Fig.2)

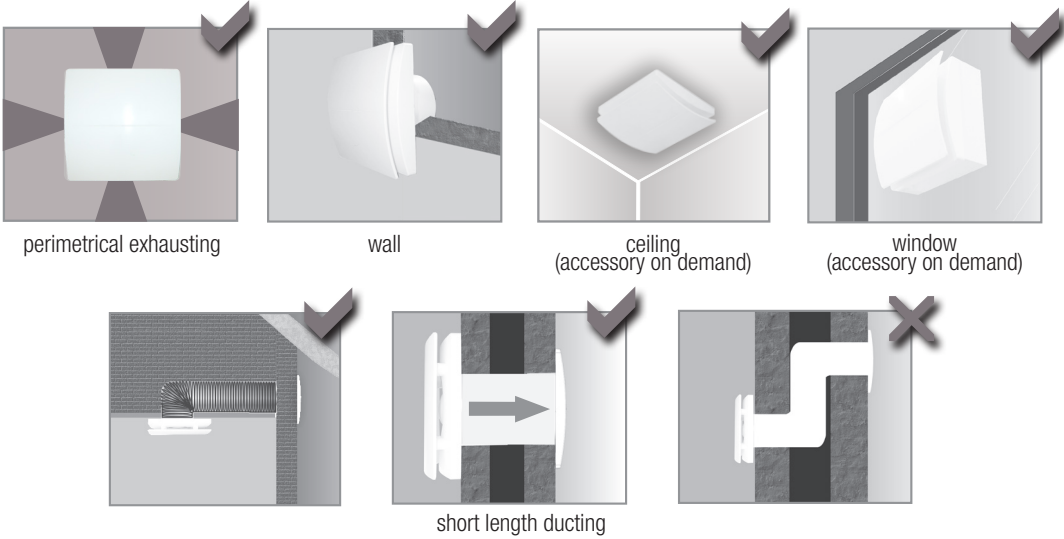

MOUNTING AND ELECTRICAL WIRING

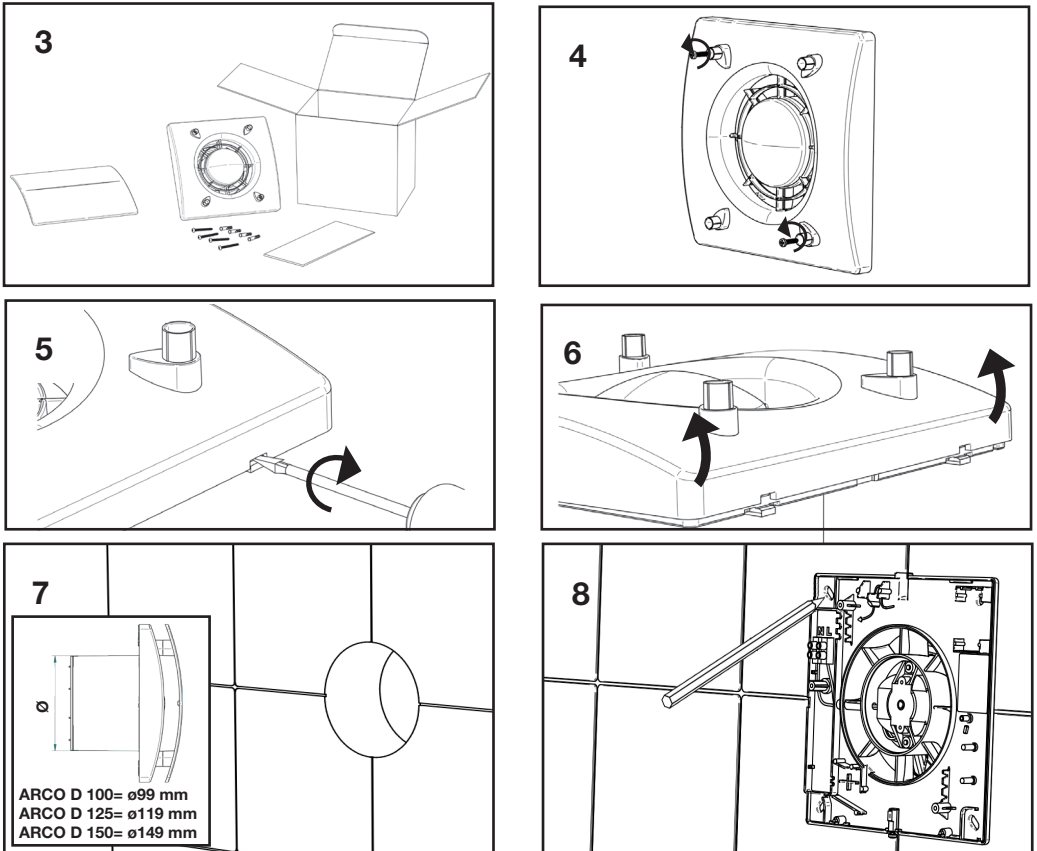

SURFACE CABLE

H03VV-F ; H05VV-F

BASE/STD $\left\{ \begin{array}{l} 2 \times 0,5 \div 1,5 \text{ mm}^2 \\ 3 \times 0,5 \div 1,5 \text{ mm}^2 \end{array} \right.$
T-HT $\left\{ \begin{array}{l} 3 \times 0,5 \div 1,5 \text{ mm}^2 \\ 4 \times 0,5 \div 1 \text{ mm}^2 \end{array} \right.$

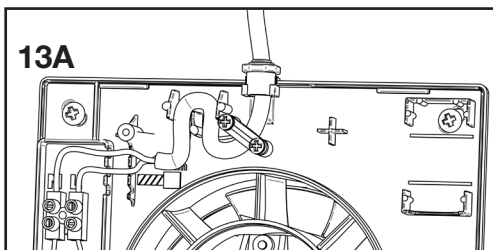
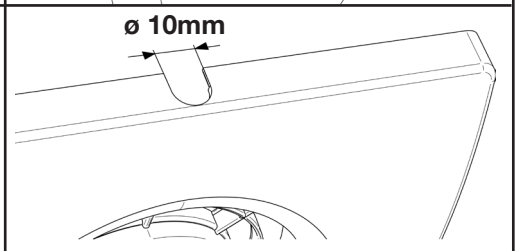
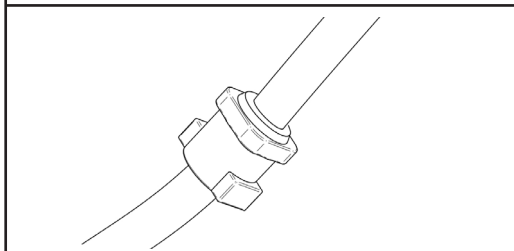
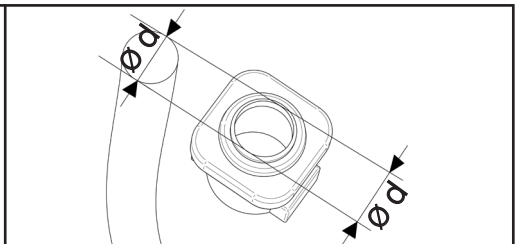
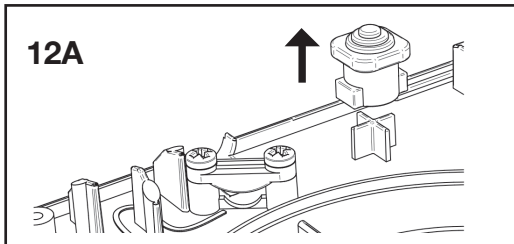
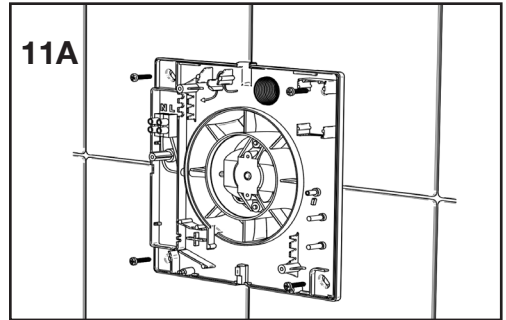
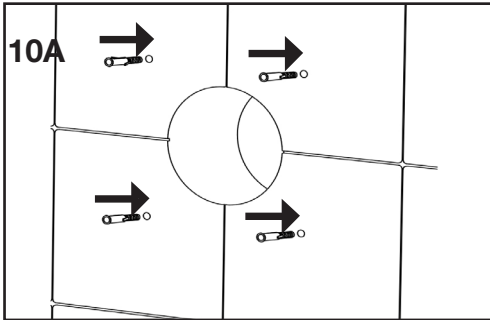
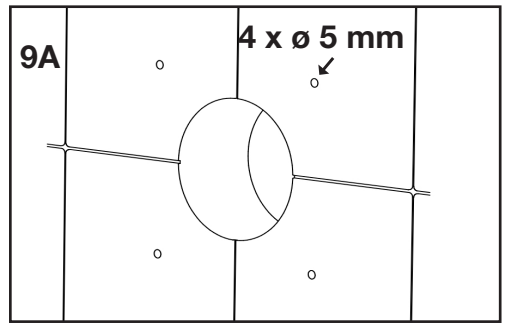

RECESSED CABLE ENTRY

H03VV-F ; H05VV-F

BASE/STD $\left\{ \begin{array}{l} 2 \times 0,5 \div 1,5 \text{ mm}^2 \\ 3 \times 0,5 \div 1,5 \text{ mm}^2 \end{array} \right.$
T-HT $\left\{ \begin{array}{l} 3 \times 0,5 \div 1,5 \text{ mm}^2 \\ 4 \times 0,5 \div 1 \text{ mm}^2 \end{array} \right.$

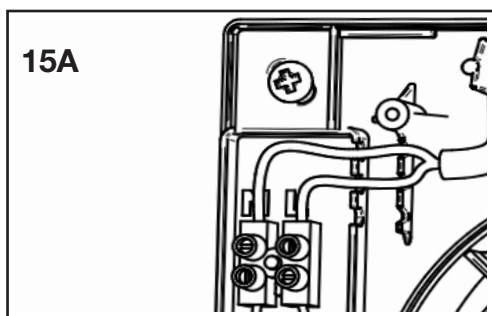
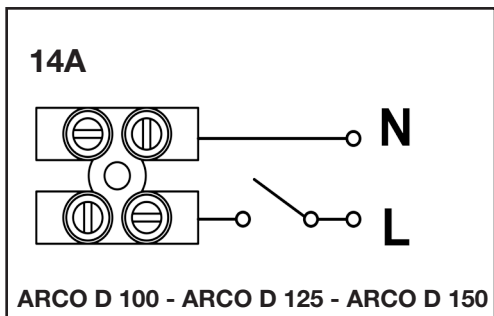
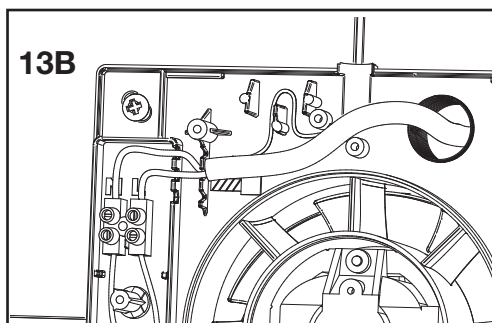
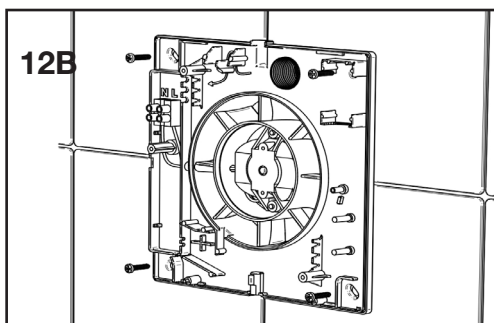
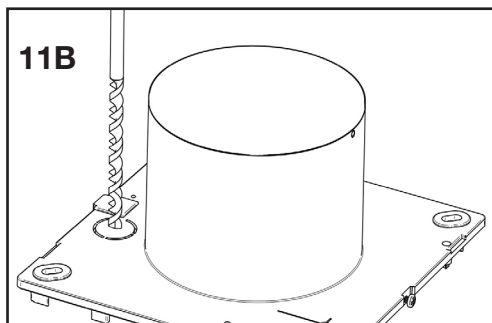
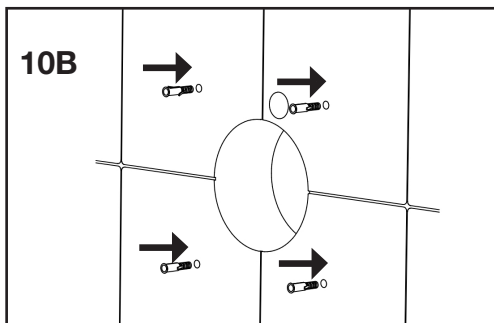
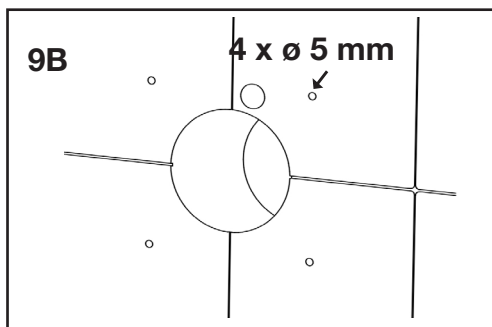

14B

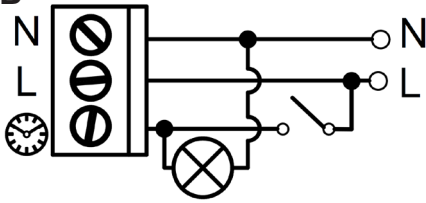

ARCO D 100T - ARCO D 125T - ARCO D 150T

15B

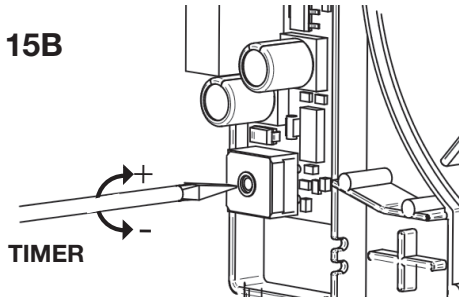

TIMER

14C

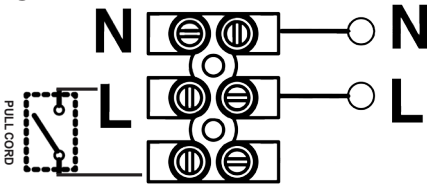

ARCO D 100C - ARCO D 125C - ARCO D 150C

15C

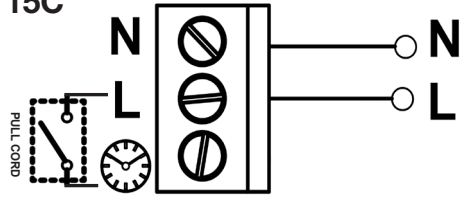

ARCO D 100HTC - ARCO D 125HTC
ARCO D 150HTC

14D

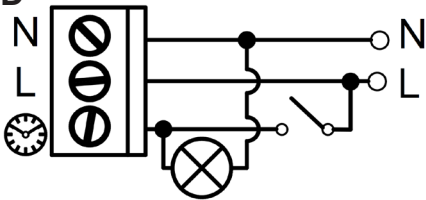

ARCO D 100HT - ARCO D 125HT
ARCO D 150HT

15D

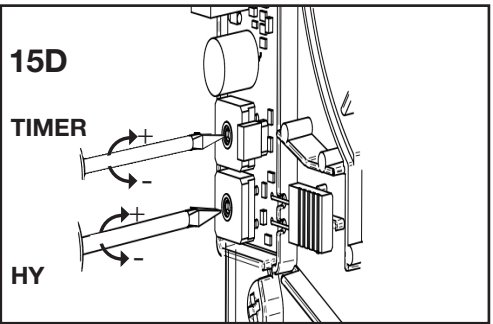

TIMER

HY

16

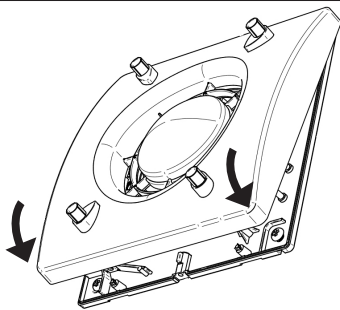

17

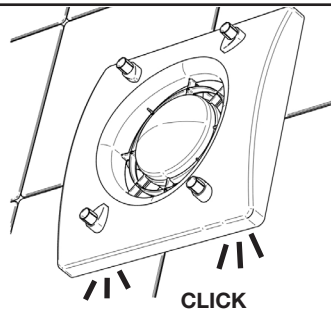

CLICK

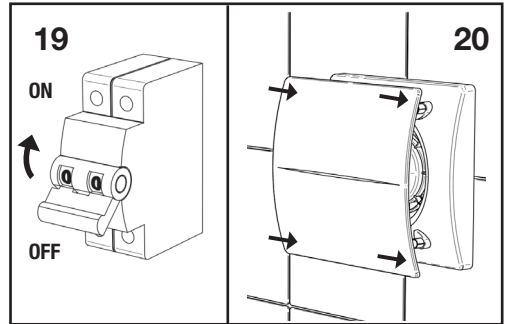
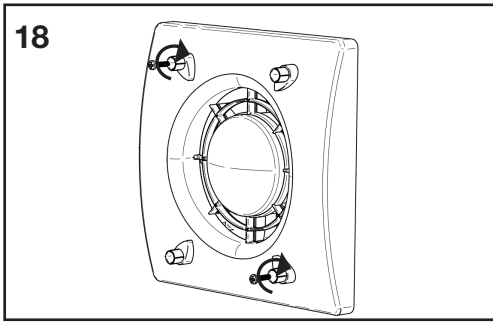

MAINTENANCE / CLEANING

The unit should be cleaned regularly as explained in this leaflet to maintain performance and warranty cover. Cleaning should be carried out as and when required but please note intervals between cleaning should not exceed 6 months. The installer should explain this cleaning regime to the homeowner/occupier and ask the homeowner/occupier to keep a record of the cleaning done on this leaflet as this will be required to be provided by the homeowner/occupier to claim against any product failure under warranty.

Year	Required Maintenance
1	Inspect, clean if required
2	Inspect, clean if required
3	Inspect, clean if required

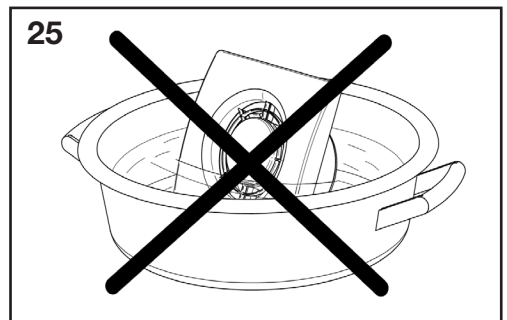
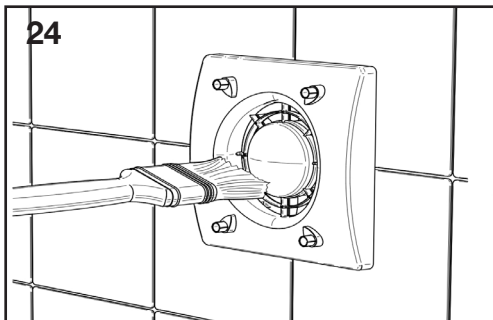
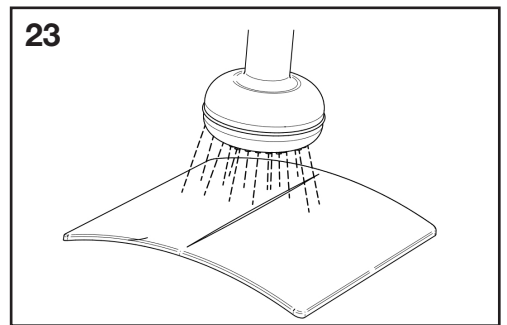
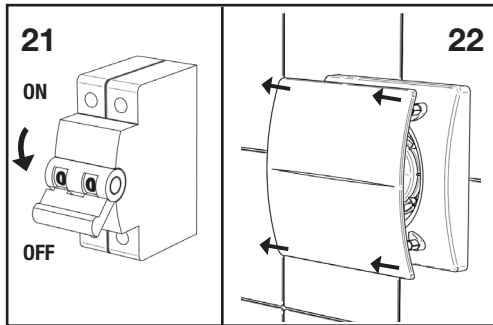

ErP Directive - Regulations 1253/2014 - 1254/2014

a)	Mark	-	ELTA FANS	
b)	Model	-	ARCO D 100, ARCO D 100T, ARCO D 100C	ARCO D 100HT, ARCO D 100HTC
c)	SEC class	-	E	C
c1)	SEC warm climates	kWh/m ² .a	-2,9	-9,6
c2)	SEC average climates	kWh/m ² .a	-10,5	-24
c3)	SEC cold climates	kWh/m ² .a	-23,9	-49,1
	Energy label	-	No	
d)	Unit typology	-	Residential - unidirectional	
e)	Type of drive	-	single speed drive	
f)	Type of Heat Recovery System	-	absent	
g)	Thermal efficiency of heat recovery	%	N/A	
h)	Maximum flow rate	m ³ /h	83	83
i)	Electric power input at maximum flow rate	W	8,3	8,3
j)	Sound power level (L _{WA})	dBA	47	47
k)	Reference flow rate	m ³ /h	83	83
l)	Reference pressure difference	Pa	10	10
m)	Specific power input (SPI)	W/m ³ /h	0,1	0,1
n1)	Control factor	-	1	0,65
n2)	Control typology	-	Manual control (no DCV)	Local demand control
o1)	Maximum internal leakage rate	%	N/A	
o2)	Maximum external leakage rate	%	N/A	
p1)	Internal mixing rate	%	N/A	
p2)	External mixing rate	%	N/A	
q)	Visual filter warning	-	N/A	
r)	Instructions to install regulated grilles	-	check the instruction booklet	
s)	Internet address for pre/disassembly instructions	-	www.eltafans.com	
t)	Airflow sensitivity to pressure variations	%	N/A	
u)	Indoor/outdoor air tightness	m ³ /h	52	52
v1)	AEC - Annual electricity consumption - warm climates	kWh	1,4	0,9
v2)	AEC - Annual electricity consumption - average climates	kWh	1,4	0,9
v3)	AEC - Annual electricity consumption - cold climates	kWh	1,4	0,9
w1)	AHS - Annual heating saved - warm climates	kWh	6,3	11,9
w2)	AHS - Annual heating saved - average climates	kWh	14	26,2
w3)	AHS - Annual heating saved - cold climates	kWh	27,3	51,3

ErP Directive - Regulations 1253/2014 - 1254/2014

a)	Mark	-	ELTA FANS	ELTA FANS
b)	Model	-	ARCO D 125, ARCO D 125T, ARCO D 125C	ARCO D 125HT, ARCO D 125HTC
c)	SEC class	-	E	C
c1)	SEC warm climates	kWh/m ² .a	-2,7	-9,5
c2)	SEC average climates	kWh/m ² .a	-10,4	-23,9
c3)	SEC cold climates	kWh/m ² .a	-23,7	-49
	Energy label	-	No	
d)	Unit typology	-	Residential - unidirectional	
e)	Type of drive	-	single speed drive	
f)	Type of Heat Recovery System	-	absent	
g)	Thermal efficiency of heat recovery	%	N/A	
h)	Maximum flow rate	m ³ /h	140	140
i)	Electric power input at maximum flow rate	W	14,6	14,6
j)	Sound power level (L _{WA})	dBA	55	55
k)	Reference flow rate	m ³ /h	140	140
l)	Reference pressure difference	Pa	10	10
m)	Specific power input (SPI)	W/m ³ /h	0,104	0,104
n1)	Control factor	-	1	0,65
n2)	Control typology	-	Manual control (no DCV)	Local demand control
o1)	Maximum internal leakage rate	%	N/A	
o2)	Maximum external leakage rate	%	N/A	
p1)	Internal mixing rate	%	N/A	
p2)	External mixing rate	%	N/A	
q)	Visual filter warning	-	N/A	
r)	Instructions to install regulated grilles	-	check the instruction booklet	
s)	Internet address for pre/disassembly instructions	-	www.eltafans.com	
t)	Airflow sensitivity to pressure variations	%	30	30
u)	Indoor/outdoor air tightness	m ³ /h	84	84
v1)	AEC - Annual electricity consumption - warm climates	kWh	1,4	0,9
v2)	AEC - Annual electricity consumption - average climates	kWh	1,4	0,9
v3)	AEC - Annual electricity consumption - cold climates	kWh	1,4	0,9
w1)	AHS - Annual heating saved - warm climates	kWh	6,3	11,9
w2)	AHS - Annual heating saved - average climates	kWh	14	26,2
w3)	AHS - Annual heating saved - cold climates	kWh	27,3	51,3

ErP Directive - Regulations 1253/2014 - 1254/2014

a)	Mark	-	ELTA FANS	ELTA FANS
b)	Model	-	ARCO D 150, ARCO D 150T, ARCO D 150C	ARCO D 150HT, ARCO D 150HTC
c)	SEC class	-	E	C
c1)	SEC warm climates	kWh/m ² .a	-3	-9,7
c2)	SEC average climates	kWh/m ² .a	-10,7	-24,1
c3)	SEC cold climates	kWh/m ² .a	-24	-49,2
	Energy label	-	No	
d)	Unit typology	-	Residential - unidirectional	
e)	Type of drive	-	single speed drive	
f)	Type of Heat Recovery System	-	absent	
g)	Thermal efficiency of heat recovery	%	N/A	
h)	Maximum flow rate	m ³ /h	253	253
i)	Electric power input at maximum flow rate	W	24,2	24,2
j)	Sound power level (L _{WA})	dBA	63	63
k)	Reference flow rate	m ³ /h	253	253
l)	Reference pressure difference	Pa	10	10
m)	Specific power input (SPI)	W/m ³ /h	0,096	0,096
n1)	Control factor	-	1	0,65
n2)	Control typology	-	Manual control (no DCV)	Local demand control
o1)	Maximum internal leakage rate	%	N/A	
o2)	Maximum external leakage rate	%	N/A	
p1)	Internal mixing rate	%	N/A	
p2)	External mixing rate	%	N/A	
q)	Visual filter warning	-	N/A	
r)	Instructions to install regulated grilles	-	check the instruction booklet	
s)	Internet address for pre/disassembly instructions	-	www.eltafans.com	
t)	Airflow sensitivity to pressure variations	%	24	24
u)	Indoor/outdoor air tightness	m ³ /h	132	132
v1)	AEC - Annual electricity consumption - warm climates	kWh	1,3	0,9
v2)	AEC - Annual electricity consumption - average climates	kWh	1,3	0,9
v3)	AEC - Annual electricity consumption - cold climates	kWh	1,3	0,9
w1)	AHS - Annual heating saved - warm climates	kWh	6,3	11,9
w2)	AHS - Annual heating saved - average climates	kWh	14	26,2
w3)	AHS - Annual heating saved - cold climates	kWh	27,3	51,3

DISPOSAL AND RECYCLING



Information on disposal of units at the end of life.

This product complies with EU Directive 2002/96/EC.

The symbol of the crossed-out dustbin indicates that this product must be collected separately from other waste at the end of its life. The user must, therefore, dispose of the product in question at suitable electronic and electro-technical waste disposal collection centres, or else send the product back to the retailer when purchasing a new, equivalent type device.

Separate collection of decommissioned equipment for recycling, treatment and environmentally compatible disposal helps to prevent negative effects on the environment and on health and promotes the recycling of the materials that make up the equipment.

Improper disposal of the product by the user may result in administrative sanctions as provided by law.

Elta Fans Limited
Building Services
46 Third Avenue
Pensnett Trading Estate
Kingswinford
West Midlands
DY6 7US
United Kingdom
T: +44 (0) 1384 275800
F: +44 (0) 1384 275810
E: bs@eltafans.co.uk

