



DCV CONTROLLER

(For use with SQS/SQT/SSDL/STD L Units)

Operating Instructions

DCV CONTROLLER

Wiring Diagram

PCB Connections

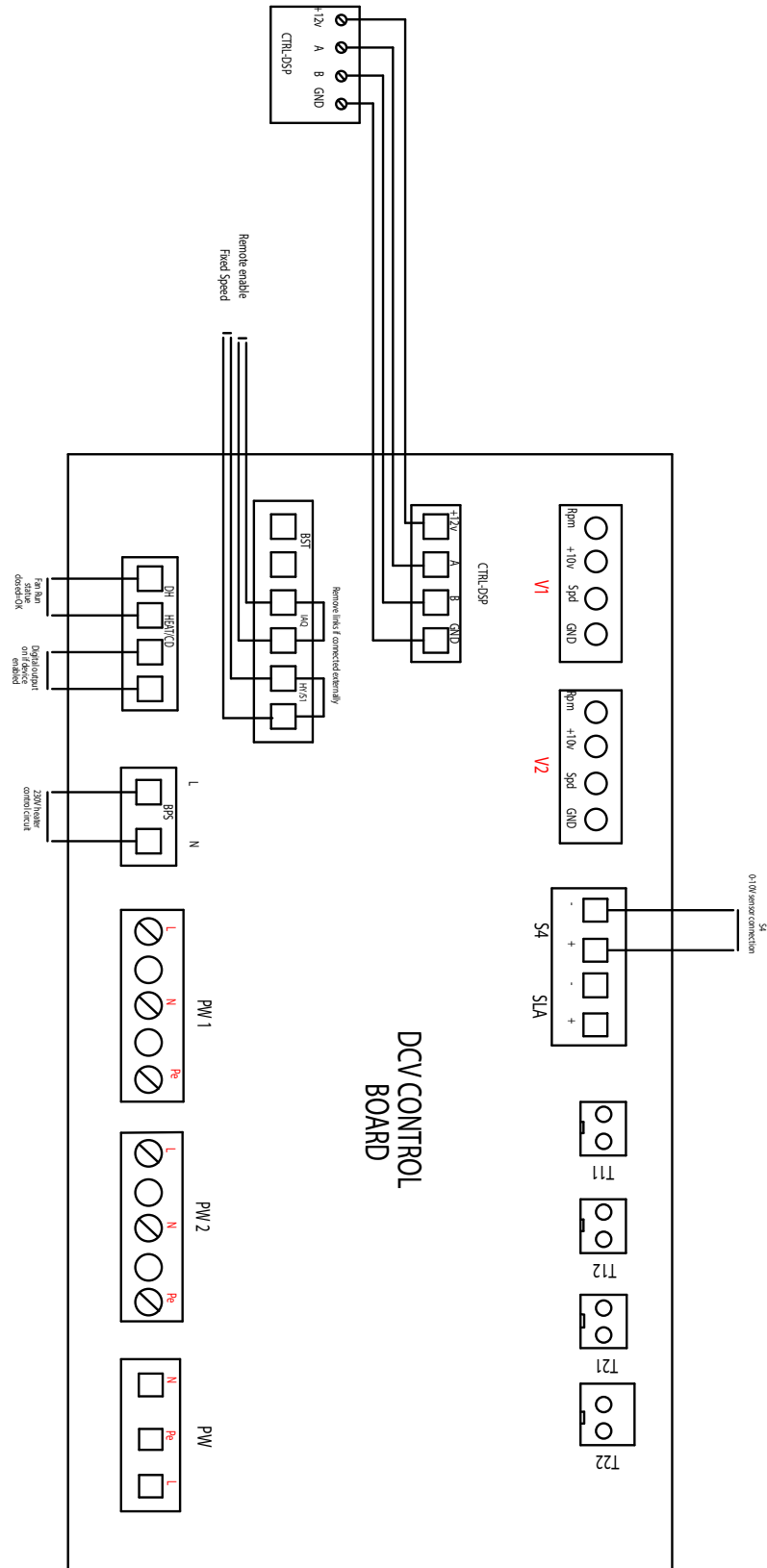

DCV CONTROLLER

Wiring Diagram

Power Supply Connections

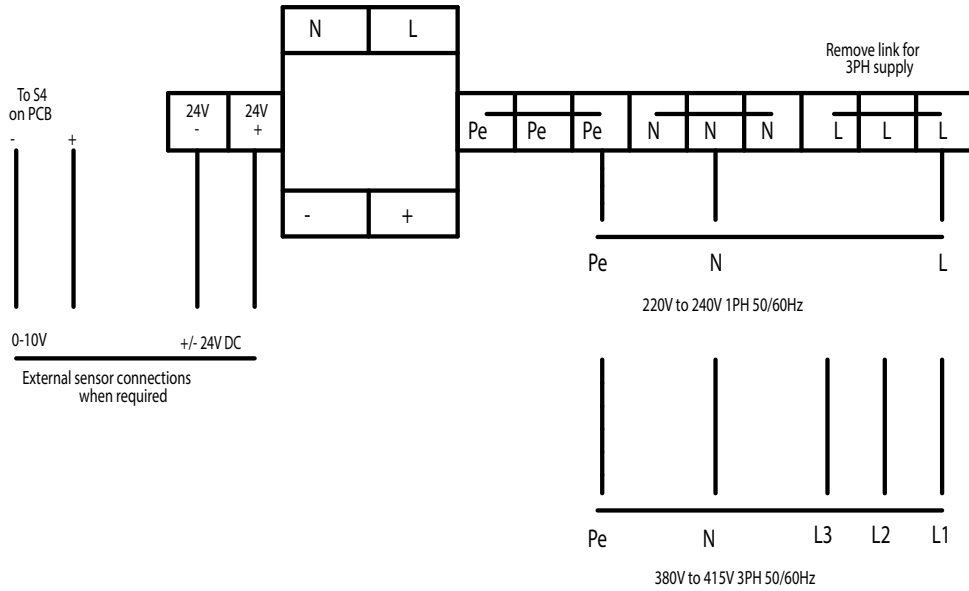

Sensor Connection

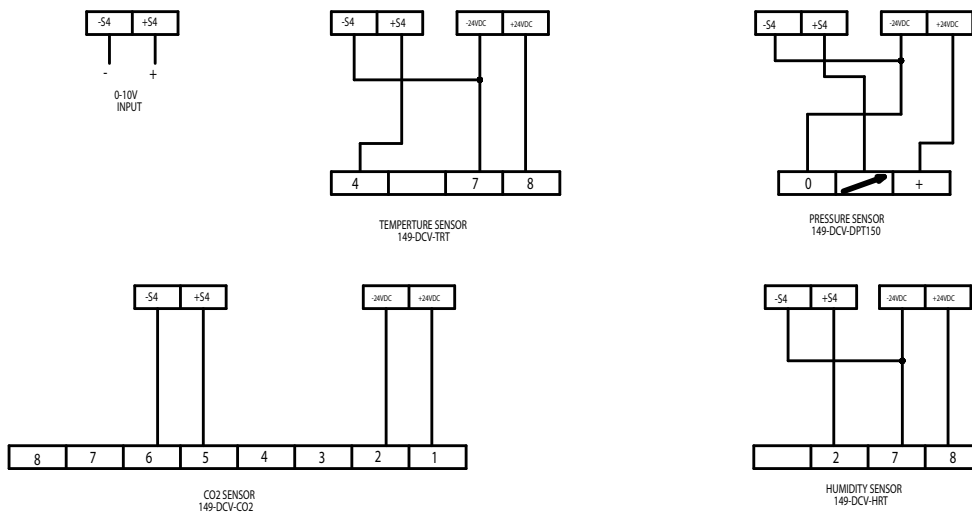

DCV CONTROLLER

Display Functions

CTRL-DSP Display

E	DATE: shows the current date
F	APPLICATION: shows the current application
G	MODE: Shows auto fan [all modes except manual] or manual position
H	TIME: shows the time
I	Remote Enable: shows remote enable is disabled
K	ESC key: to exit and go back to the previous menu
L	OK key: to enter the selected menu
M	To go to the RIGHT in menus
N	To go to the LEFT in menus
O	To go DOWN in menus
P	To go UP in menus
Q	On/Off: power the unit
U	TIMECLOCK: shows timeclock on/off
R	FAULT: shows error alarm, refer to error codes
X	HEATER: Shows heater output is active

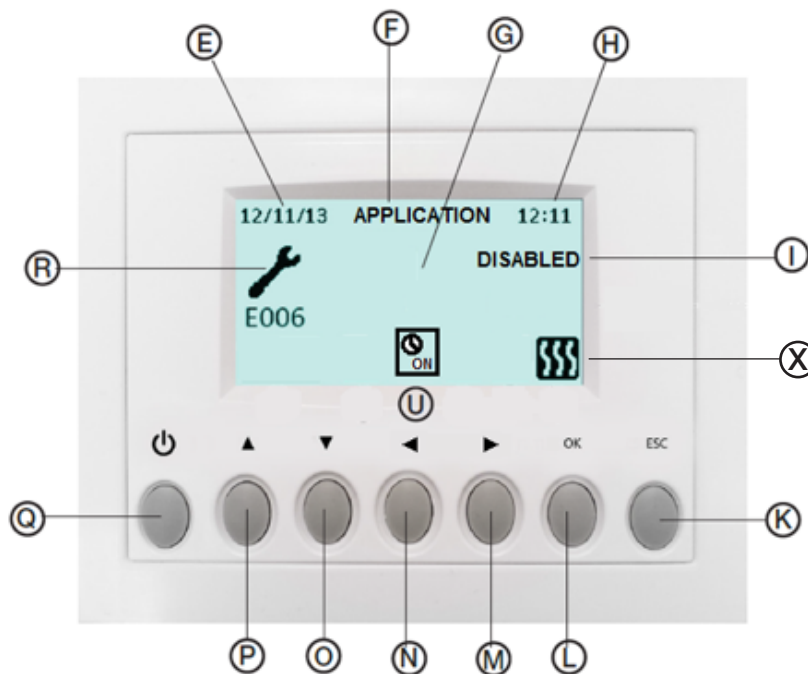

When powered in auto mode, the CTRL-DSP displays as follows in figure 1 (Auto mode refers to applications 0-10V, Pressure, CO₂, RH and Temperature)

When powered in manual mode, the CTRL-DSP displays as follows in figure 2 (Manual mode refers to application Manual)

Main Menu on CTRL-DSP

To enter the main menu press OK or ESC To exit the main menu press ESC or wait approx. 60 seconds

The recommended cable to wire between the DCV controller and the CTRL-DSP display is 4 pole, twisted paired, communication cable.

The maximum cable distance for the CTRL-DSP display is 30 meters.

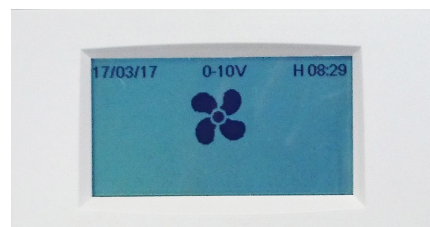

figure 1

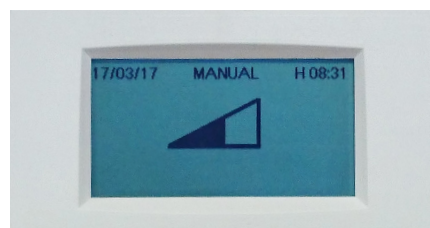

figure 2

DCV CONTROLLER

Display Functions

Display Functions / Main Menu Functions

Main Menu	Use ▲ or ▼ to select required menu
	Press OK to enter any parameter
	*P02 to P04 only visible in selected applications 0-10V, Pressure, CO ₂ , RH and Temperature
Language	Allows selection of language between English and Italian
	Press OK to enter
	Language is flashing: Use ▲ or ▼ to choose
	Press OK to select
	*The factory setting (DEFAULT) is English
Date/Time	Allows selection of date and time
	Press OK to enter
	Use ▲ or ▼ to choose
	Press OK for setting and again to confirm
	Press ESC to go back to the previous menu
P00: Fan Mode	Allows selection of Fan Mode
	Press OK to enter
	Fan mode is flashing: Use ▲ or ▼ to choose
	Press OK to select
	*The factory setting (DEFAULT) is SINGLE for single fans and TWIN for twin fans
	**Refer to Fan Mode Control Functions
P01: Application	Allows selection of desired Application
	Press OK to enter
	Application is flashing: Use ▲ or ▼ to choose
	Applications available:
	0-10V: input signal 0-10 VDC determines the fans speed 0-100% of the configured max. Speed. High input signal gives high fan speed
	MANUAL: The fan speed is set manually using the CTRL-DSP's UP and DOWN buttons
	PRESSURE: Duct air pressure (Control input signal 0-10VDC mapped to pressure sensor range) is controlled by a PID controller (Proportional, Integrating and Derivating). High pressure value gives low fan speed
	RH: The room relative humidity (control input signal 0-10 VDC mapped to RH sensor range) is controlled by a P controller (P band). High relative humidity gives high fan speed.
	CO₂: The room's CO ₂ content (Control input signal 0-10 VDC mapped to CO ₂ sensor range) is controlled by a P controller (P band). High CO ₂ rate gives high fan speed.
	TEMPERATURE: The room temperature (control input signal 0-10 VDC mapped to Temperature sensor range, or T11 input, depending on the value of P12 parameter) is controlled by a P controller
	(P band). High temperature gives high fan speed.
Press OK to select	
*The factory setting (DEFAULT) is 0-10V	
**Refer to Application Control Functions for further information	

DCV CONTROLLER

Display Functions

P02: Sensor Range MIN	Parameter is not visible when application is MANUAL																																			
	Allows selection of desired minimum sensor value																																			
	Press OK to enter																																			
	Value is flashing: Use ▲ or ▼ to choose																																			
	Press OK to select																																			
	Available settings are																																			
	<table border="1"> <thead> <tr> <th>Application</th> <th>Default</th> <th>Min</th> <th>Max</th> <th>Min value change</th> <th>Unit/Value</th> </tr> </thead> <tbody> <tr> <td>Temperature</td> <td>5</td> <td>0</td> <td>10</td> <td>1</td> <td>°C</td> </tr> <tr> <td>CO₂</td> <td>0</td> <td>0</td> <td>1000</td> <td>100</td> <td>ppm</td> </tr> <tr> <td>RH</td> <td>30</td> <td>20</td> <td>50</td> <td>1</td> <td>%</td> </tr> <tr> <td>Pressure</td> <td>0</td> <td>0</td> <td>0</td> <td>0</td> <td>Pa</td> </tr> </tbody> </table>						Application	Default	Min	Max	Min value change	Unit/Value	Temperature	5	0	10	1	°C	CO ₂	0	0	1000	100	ppm	RH	30	20	50	1	%	Pressure	0	0	0	0	Pa
	Application	Default	Min	Max	Min value change	Unit/Value																														
Temperature	5	0	10	1	°C																															
CO ₂	0	0	1000	100	ppm																															
RH	30	20	50	1	%																															
Pressure	0	0	0	0	Pa																															
P03: Sensor Range MAX	Parameter is not visible when application is MANUAL																																			
	Allows selection of desired maximum sensor value																																			
	Press OK to enter																																			
	Value is flashing: Use ▲ or ▼ to choose																																			
	Press OK to select																																			
	Available settings are																																			
	<table border="1"> <thead> <tr> <th>Application</th> <th>Default</th> <th>Min</th> <th>Max</th> <th>Min value change</th> <th>Unit/Value</th> </tr> </thead> <tbody> <tr> <td>Temperature</td> <td>30</td> <td>25</td> <td>50</td> <td>1</td> <td>°C</td> </tr> <tr> <td>CO₂</td> <td>2000</td> <td>1000</td> <td>2500</td> <td>100</td> <td>ppm</td> </tr> <tr> <td>RH</td> <td>95</td> <td>80</td> <td>100</td> <td>1</td> <td>%</td> </tr> <tr> <td>Pressure</td> <td>300</td> <td>50</td> <td>1000</td> <td>10</td> <td>Pa</td> </tr> </tbody> </table>						Application	Default	Min	Max	Min value change	Unit/Value	Temperature	30	25	50	1	°C	CO ₂	2000	1000	2500	100	ppm	RH	95	80	100	1	%	Pressure	300	50	1000	10	Pa
	Application	Default	Min	Max	Min value change	Unit/Value																														
Temperature	30	25	50	1	°C																															
CO ₂	2000	1000	2500	100	ppm																															
RH	95	80	100	1	%																															
Pressure	300	50	1000	10	Pa																															
P04: Setpoint	Parameter is not visible when application is MANUAL																																			
	Allows selection of desired setpoint value																																			
	Press OK to enter																																			
	Value is flashing: Use ▲ or ▼ to choose																																			
	Press OK to select																																			
	Available settings are																																			
	<table border="1"> <thead> <tr> <th>Application</th> <th>Default</th> <th>Min</th> <th>Max</th> <th>Min value change</th> <th>Unit/Value</th> </tr> </thead> <tbody> <tr> <td>Temperature</td> <td>22</td> <td>15</td> <td>30</td> <td>1</td> <td>°C</td> </tr> <tr> <td>CO₂</td> <td>1000</td> <td>0</td> <td>2000</td> <td>100</td> <td>ppm</td> </tr> <tr> <td>RH</td> <td>70</td> <td>30</td> <td>95</td> <td>1</td> <td>%</td> </tr> <tr> <td>Pressure</td> <td>150</td> <td>0</td> <td>300</td> <td>10</td> <td>Pa</td> </tr> </tbody> </table>						Application	Default	Min	Max	Min value change	Unit/Value	Temperature	22	15	30	1	°C	CO ₂	1000	0	2000	100	ppm	RH	70	30	95	1	%	Pressure	150	0	300	10	Pa
	Application	Default	Min	Max	Min value change	Unit/Value																														
Temperature	22	15	30	1	°C																															
CO ₂	1000	0	2000	100	ppm																															
RH	70	30	95	1	%																															
Pressure	150	0	300	10	Pa																															
P05: PID Control	Allows selection of PID response																																			
	Press OK to enter																																			
	PID mode is flashing: Use ▲ or ▼ to choose																																			
	PID Modes available:																																			
	SLOW: Global gain set to 0.2, other PID values default																																			
	NORMAL: Global gain set to 0.5, other PID values default																																			
	FAST: Global gain set to 0.9, other PID values default																																			
	CUSTOM: Custom is automatically selected if advanced settings in service menu changed																																			
Press OK to select																																				
*The factory setting (DEFAULT) is NORMAL																																				
**Refer to Control Functions and SERVICE Menu for advanced PID settings																																				

DCV CONTROLLER

Display Functions

P06: Fixed speed value	Allows selection of the fixed speed value				
	When the device is enabled and the fixed speed input is closed, the unit runs at a fixed speed				
	Press OK to enter				
	Value is flashing: Use ▲ or ▼ to choose				
	Press OK to select				
	Available settings are				
	Default	Min	Max	Min value change	Unit/Value
10	10	100	1	%	
P07: Run On Time (minutes)	Allows selection of the run on time (minutes)				
	When the device is enabled and the remote enable input is opened, the unit will continue running for the set value (in minutes)				
	Press OK to enter				
	Value is flashing: Use ▲ or ▼ to choose				
	Press OK to select				
	Available settings are				
	Default	Min	Max	Min value change	Unit/Value
3	3	20	1	minutes	
P08: Min Fan Speed	Allows adjustment of the minimum fan speed value				
	Press OK to enter				
	Value is flashing: Use ▲ or ▼ to choose				
	Press OK to select				
	Available settings are				
	Default	Min	Max	Min value change	Unit/Value
	10	10	50	1	%
P09: Max Fan Speed	Allows adjustment of the maximum fan speed value				
	Press OK to enter				
	Value is flashing: Use ▲ or ▼ to choose				
	Press OK to select				
	Available settings are				
	Default	Min	Max	Min value change	Unit/Value
	100	50	100	1	%
P10: Slave Min Fan Speed	Allows adjustment of the minimum fan speed value for a connected Slave fan (P00 set to MASTER/SLAVE)				
	Press OK to enter				
	Value is flashing: Use ▲ or ▼ to choose				
	Press OK to select				
	Available settings are				
	Default	Min	Max	Min value change	Unit/Value
	10	10	50	1	%
P11: Slave Max Fan Speed	Allows adjustment of the maximum fan speed value for a connected Slave fan (P00 set to MASTER/SLAVE)				
	Press OK to enter				
	Value is flashing: Use ▲ or ▼ to choose				
	Press OK to select				
	Available settings are				
	Default	Min	Max	Min value change	Unit/Value
	100	50	100	1	%

DCV CONTROLLER

Display Functions

P12: Temperature Input	Parameter is only visible when application is TEMPRETURE	
	Allows selection of the temperature sensor input	
	Press OK to enter	
	Value is flashing: Use ▲ or ▼ to choose	
	Press OK to select	
	Available settings are	
	S4	0-10V input from remote temperature sensor
T11	Pre-fitted duct sensor	
Weekly Timer	Allows selection of weekly timer and configuration of daily timer On/Off settings	
	Press OK to enter	
	Value is flashing: Use ▲ or ▼ to choose ON	
	Use ▲ or ▼ to select day of the week	
	Press OK to select ON time	
	Use ▲ or ▼ to select time	
	Use ▲ or ▼ to scroll through values	
	"Copy on [next day]": OK to choose YES, ESC to choose NO	
	"Save program?": OK to choose YES, ESC to choose NO	
	NOTE: If remote enable input (IAQ) is closed, it will over ride the weekly timer function	
	Available settings are four ON/OFF times per day	
		Day
ON		OFF
00:00		00:00
00:00		00:00
00:00		00:00
00:00		00:00
Working Hours Counter	Provides a count of number of unit working hours. This value cannot be changed. The Data is saved both on the CTRL-DSP and the PCB	
	Press OK to enter	
	Press OK / ESC to return to main menu	
Save Settings	Allows to save the setting of parameters in the internal memory of the CTRL-DSP to be loaded afterwards in other units.	
	Press OK to enter.	
	Use ▲ or ▼ to choose the position where to save the setting. Up to 8 different settings can be saved.	
	Press OK to select.	
	Press OK to confirm.	
	Press ESC to go back to the previous menu	
Load Settings	Allows to load the saved setting on the next unit	
	Press OK to enter.	
	Use ▲ or ▼ to choose the desired saved setting	
	Press OK to select.	
	Press OK to confirm.	
	Press ESC to go back to the previous menu	

DCV CONTROLLER

Display Functions

Restore Default Settings	Allows restoring all the factory settings (DEFAULT).
	Press OK to enter.
	Press OK to confirm.
Contrast	Allows you to set the LCD contrast.
	Use ▲ or ▼ to increase or decrease the contrast.
	Press OK to confirm.
Debug Page	Shows the internal functional parameters of the unit.
	Press OK to enter.
	Press ESC to go back to the previous menu.

Service Menu Functions

Service Menu	Service Menu on CTRL-DSP				
	To enter the service menu, change P01 to anything other than MANUAL, then from the main screen press and hold OK for 3 seconds				
	To exit to the main screen, press ESC				
S00: Parameter summary	Shows values for each parameter				
	Use ▲ or ▼ to view parameters				
	Press ESC to go back to the previous menu.				
S01: Fan status signal	Allows selection of the motor protection method (FACTORY SET)				
	Press OK to enter				
	Value is flashing: Use ▲ or ▼ to choose				
	Press OK to select				
	Available settings are				
	TACHO	The fan(s) has a tacho output (open collector hall effect sensor) connected to RPM-GND. The running status is indicated by the presence of the RPM signal			
RELAY	The fan(s) has a relay output (closed when fan is running) connected to RPM-GND. The running status is indicated by a closed link between RPM and GND				
S02: Global Gain	Allows adjustment of the global gain for applications to be fine-tuned/ adjusted beyond P05				
	Press OK to enter				
	Value is flashing: Use ▲ or ▼ to choose				
	Press OK to select				
	*Any change from default setting will drive P05 to CUSTOM				
	Available settings are				
		P05 Original Setting	Default	Min	Max
	Slow	0.2	0.1	1	0.1
	Normal	0.5	0.1	1	0.1
	Fast	0.9	0.1	1	0.1

DCV CONTROLLER

Display Functions

S03: Proportional Band	Allows adjustment of the proportional band for applications to be fine-tuned/ adjusted beyond P05					
	Press OK to enter					
	Value is flashing: Use ▲ or ▼ to choose					
	Press OK to select					
	*Any change from default setting will drive P05 to CUSTOM					
	Available settings are					
	Application	Default	Min	Max	Min Value Change	Unit/Value
0-10V	0.1	1	1	0.1	1	
Temperature	0.1	1	1	0.1	1	
CO₂	0.1	1	1	0.1	1	
RH	0.1	1	1	0.1	1	
Pressure	0.1	1	1	0.1	1	
S04: Integration Time	Parameter is only visible when application is PRESSURE					
	Allows adjustment of the integration time for applications to be fine-tuned/ adjusted beyond P05					
	Press OK to enter					
	Value is flashing: Use ▲ or ▼ to choose					
	Press OK to select					
	*Any change from default setting will drive P05 to CUSTOM					
	Available settings are					
Application	Default	Min	Max	Min Value Change	Unit/Value	
Pressure	10	5	500	5	seconds	
S05: Derivation Time	Parameter is only visible when application is PRESSURE					
	Allows adjustment of the derivation time for applications to be fine-tuned/ adjusted beyond P05					
	Press OK to enter					
	Value is flashing: Use ▲ or ▼ to choose					
	Press OK to select					
	*Any change from default setting will drive P05 to CUSTOM					
	Available settings are					
Application	Default	Min	Max	Min Value Change	Unit/Value	
Pressure	0	0	500	10	seconds	
Debug Page	Shows the internal functional parameters of the unit.					
	Press OK to enter.					
	Press ESC to go back to the previous menu.					
Control Debug Page	Shows the internal control parameters of the unit.					
	Press OK to enter.					
	Press ESC to go back to the previous menu.					
	Selected application	(e.g. temperature)				
	Setpoint	(e.g. 20°C)				
	Measured Parameter	(e.g. 17.9°C)				
	Proportional gain Kp	A parameter of the PID controller, calculated from Global Gain and Proportional Band parameters (service menu)				
Integral gain Ki	A parameter of the PID controller (used only in Pressure application), calculated from Kp and Integration Time (service menu)					
Derivative gain Kd	A parameter of the PID controller (used only in Pressure application), calculated from Kp and Derivation Time (service menu)					

DCV CONTROLLER

Control Functions

Control Functions

Fans will run alternatively, changing duty every 6th hour. If there's a fan failure, only the "surviving" fan is run and an error message is displayed. The duty switch can be manually forced by pressing the LEFT or RIGHT button for 5s

Two independent fans used for twin fan applications (one fan must be DCV)

Single Fan

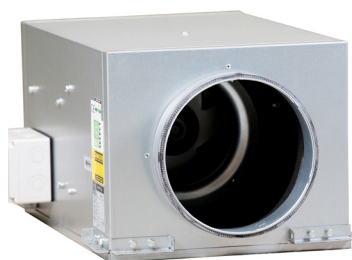

Pre-wired DCV single fan

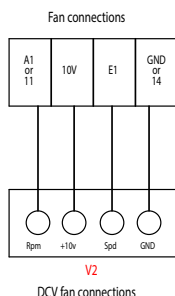

Second EC



Fans will run alternatively, changing duty every 6th hour. If there's a fan failure, only the "surviving" fan is run and an error message is displayed. The duty switch can be manually forced by pressing the LEFT or RIGHT button for 5s.

Master/Slave Fans

Fan 2 (SLAVE) speed control is equivalent to Fan 1 (MASTER) speed control (each one relative to their limits, set by parameters) (one fan must be DCV)

Pre-wired DCV single fan

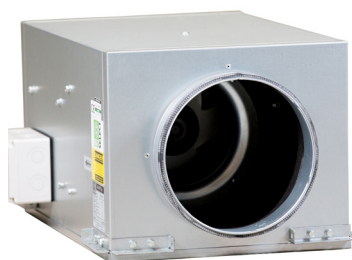

Pre-wired DCV single fan

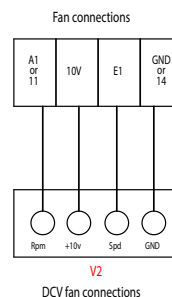

DCV CONTROLLER

Control Functions

Remote ON/OFF (Device Enabled)

The fan controller will be enabled if the digital input REMOTE ENABLE (IAQ) is active (contact closed). This is indicated by digital output DEVICE ENABLED (HEAT/CD) = ON.

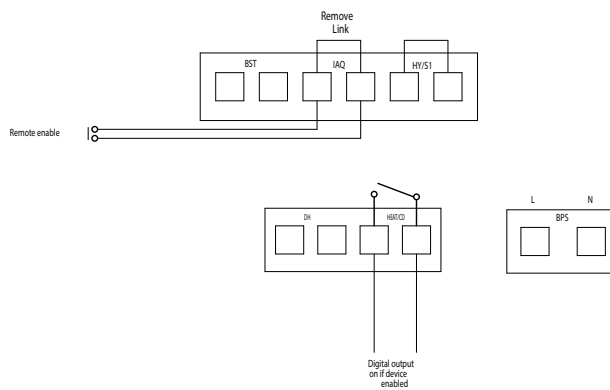

Internal Timeclock enable

It is possible to operate the on / off function by the weekly timer (parameter setting “weekly timer”). This allows up to four on and four off settings per day. Fan operation in conjunction with remote enable (terminal IAQ) is shown below.

IAQ Terminals	Weekly Timer (on/off times set)	Fan On / Off	Device Enabled Output
OPEN	ON	ON	ON
OPEN	OFF	OFF	OFF
CLOSED	ON	ON	ON
CLOSED	OFF	ON	ON

Fixed Speed

When the device is enabled and the HY/S1 input is open, the unit runs at a fixed speed set by the P06 parameter (relative to speed limits)

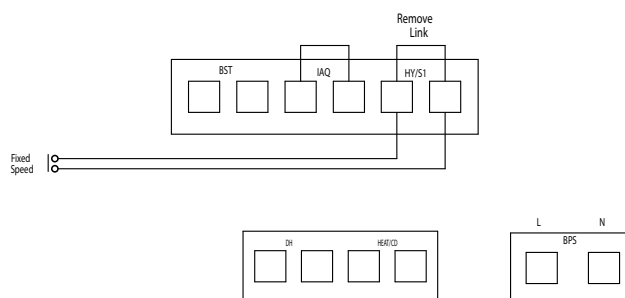

Trickle / Boost (using Fixed Speed function)

By setting parameter P06 (fixed speed) to 100% and P09 (max fan speed) set to 100% it is possible to have a trickle speed (defined by sensor output in Non-manual application or the manual set speed in Manual application) and a boost speed by opening connections HY/S1 (fixed speed)

HY/S1 Terminals	Application (P01)	TRICKLE/BOOST	VALUE
OPEN	0-10V/ PRESSURE/RH/TEMPERATURE	BOOST	P06/P09
CLOSED	0-10V/PRESSURE/RH/TEMPERATURE	TRICKLE	SENSOR OUTPUT
OPEN	MANUAL	BOOST	P06/P09
CLOSED	MANUAL	ON	MANUAL SETTING

DCV CONTROLLER

Control Functions

0-10V/PRESSURE/RH/TEMPERATURE

Application With trickle speed defined by sensor output rather than a fixed value, the ventilation is guaranteed by the requirements of the sensor, e.g. if CO₂ sensor detects levels above the desired set point then the sensor will call for a higher trickle speed as CO₂ levels have been detected that require ventilation at a higher speed

MANUAL Application

The trickle speed is defined by the value manually set using the CTRL-DSP ▲ or ▼ buttons

Night Set Back (using Fixed Speed function)

By setting parameter P06 (fixed speed) to 20% and P08 (min fan speed) set to 20% it is possible to have a night set back by opening connections HY/S1 (fixed speed).

HY/S1 Terminals	Application (P01)	Night Set Back (NSB)/Normal	VALUE
OPEN	0-10V/PRESSURE/RH/TEMPERATURE	NSB	P06/P08
CLOSED	0-10V/PRESSURE/RH/TEMPERATURE	NORMAL	SENSOR OUTPUT
OPEN	MANUAL	NSB	P06/P08
CLOSED	MANUAL	NORMAL	MANUAL SETTING

0-10V/PRESSURE/RH/TEMPERATURE Application

Night Set Back is defined by the status of connections HY/S1, when open the fan speed is defined by parameters P06 and P08 When connections HY/S1 are closed, the speed defined by sensor output rather than a fixed value, the ventilation is guaranteed by the requirements of the sensor, e.g. if CO₂ sensor detects levels below the desired set point then the sensor will call for a lower speed as CO₂ levels have been detected that require ventilation to be less, this ensure that over ventilation is not experienced.

MANUAL Application

The NORMAL operating speed is defined by the value manually set using the CTRL-DSP ▲ or ▼ buttons

Fan Status

If fans are OK (no failure), this is indicated by digital output FAN RUN STATUS (DH) = ON.

Heater Fan Over run

Run on time is required to allow heat dissipation if the heater output is ON in Temperature application (or OFF if less than 3 minutes) with internal time clock in an OFF mode and the remote enable input is off; run on time is adjustable via a dedicated parameter (min. 3 minutes).

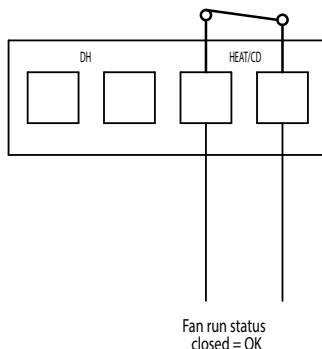

DCV CONTROLLER

Control Functions

Heater Output

In temperature mode, if the measured sensor temperature falls below the set point, the output BPS provides a 240V output to switch a heater control circuit

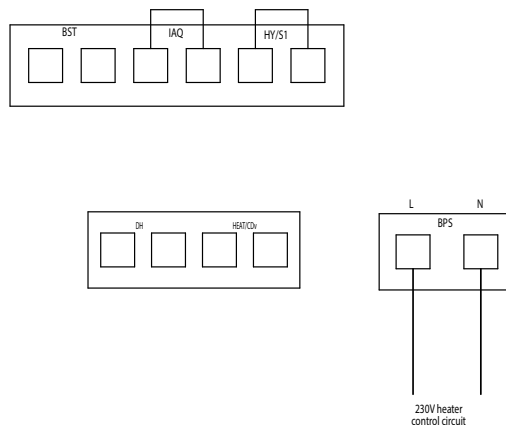

Fault Diagnostics

In the event of a fault, Exx error code shows on user display. Error description

E000	no connection between CTRL-DSP and PCB
E001	FAN 1 fault
E002	FAN 2 fault
E003	T11 fault (only possible if P12 = T11)
E004	(spare)
E005	(spare)
E006	(spare)
E007	(spare)
E008	CTRL-DSP internal clock error

Applications

The controller software is designed to handle 6 different Applications. Each application has its own set of parameters (input value range, setpoints, p band, etc.) and control function. The application is preselected at factory but can be changed in field as other parameters using the CTRL-DSP.

When the device is enabled, the fan speeds are controlled by the value of the CONTROL INPUT SIGNAL, depending on the application.

0-10V Control

Control input signal 0-10 VDC determines the fans speed 0-100% of configured max. Speed. High input signal gives high fan speed.

Where:

$$\Delta \text{ speed [\%]} = \frac{40 * \text{Global Gain}}{\text{Prop.Band (0+10V)}} * \text{error}$$

$$\text{error} = V_{\text{measured}} - V_{\text{setpoint}}$$

DCV CONTROLLER

Control Functions

Temperature

The room temperature (control input signal 0-10 VDC via Temperature, or pre-fitted T11 input, depending on the value of P12 parameter) is controlled by P band. High temperature gives high fan speed.

Where:

$$\Delta \text{ speed [\%]} = \frac{40 * \text{Global Gain}}{\text{Prop.Band (Temperature)}} * \text{error}$$

$$\text{error} = T_{\text{measured}} - T_{\text{setpoint}}$$

CO2

The room's CO2 content (Control input signal 0-10 VDC via CO2 sensor) is controlled by P band. High CO2 rate gives high fan speed.

Where:

$$\Delta \text{ speed [\%]} = \frac{40 * \text{Global Gain}}{\text{Prop.Band (CO}_2\text{)}} * \text{error}$$

$$\text{error} = \text{CO}_2_{\text{measured}} - \text{CO}_2_{\text{set point}}$$

Relative Humidity

The room relative humidity (control input signal 0-10 VDC via RH sensor) is controlled by P band. High relative humidity gives high fan speed.

Where:

$$\Delta \text{ speed [\%]} = \frac{40 * \text{Global Gain}}{\text{Prop.Band (RH)}} * \text{error}$$

$$\text{error} = \text{RH}_{\text{measured}} - \text{RH}_{\text{set point}}$$

Pressure

Duct air pressure (Control input signal 0-10VDC via pressure sensor) is controlled by a PID controller (Proportional, Integrating and Derivating). High pressure value gives low fan speed

$$\Delta \text{ speed [\%]} = - \frac{2 * \text{Global Gain}}{\text{Prop.Band (pressure)}} * \left[\text{error} + \frac{\int \text{error} * dt}{\text{Integration Time}} + \text{Derivation} * \frac{d(P_{\text{measured}})}{dt} \right]$$

In the main menu, the user can choose between different PID CONTROL settings:

Normal: the S02 (Global Gain) parameter is set to 0.5, other PID values to default

Slow: the S02 (Global Gain) parameter is set to 0.2, other PID values to default

Fast: the S02 (Global Gain) parameter is set to 0.9, other PID values to default

For the advanced users and/or feedback fine tuning, it is possible to adjust the parameters S02 to S05 manually in the SERVICE MENU. After a modification of one of the above parameters in the SERVICE MENU, the P05 PID CONTROL parameter is automatically set to CUSTOM.

Manual

The fan speed is set manually using the CTRL-DSP's UP and DOWN buttons (adjustment increments of 1%).

Building Services

Tel **+44 (0) 1384 275800**
Fax **+44 (0) 1384 275810**
Email **info@eltafans.co.uk**

46 Third Avenue, Pensnett Trading Estate, Kingswinford,
West Midlands, DY6 7US United Kingdom

Applied Technology & Building Services Export

Tel **+44 (0) 1489 566500**
Fax **+44 (0) 1489 566555**
Email **at@eltafans.co.uk / export@eltafans.co.uk**

17 Barnes Wallis Road, Segensworth East Industrial Estate,
Fareham, Hampshire, PO15 5ST United Kingdom

eltafans.com

535-IOM0045-01-2023 Issue D



BS EN ISO 9001:2015 FM 556465

