

SANO PIV LOFT

Loft Mounted Positive
Input Ventilation Unit

Helping provide Whole Home Ventilation,
Condensation Dampness Control and
Radon Gas Control



SANO PIV LOFT

Loft Mounted Positive Input Ventilation Unit



APPLICATION

The **SANO PIV Loft** is a loft mounted ultra quiet, low energy, low maintenance, home ventilation unit.

The unit is designed to help ventilate a home using the well-established **Positive Input Ventilation (PIV)** principle.

PIV units have been preventing and curing condensation dampness related problems in homes for decades. They are also used to control other indoor air pollutants and have even proven to be an effective means for reducing Radon gas in some properties.

CONDENSATION CONTROL, IMPROVED INDOOR AIR QUALITY & RADON CONTROL FOR HOMES

ULTRA QUIET
VERY LOW RUNNING COSTS
WIDE OPERATING RANGE
VARIOUS CONTROL OPTIONS

OPERATION

External air is drawn into the loft by the **SANO PIV Loft** unit. Before it passes through the unit's filter, the air increases in temperature as it utilises otherwise unused energy in the loft from solar gain and heat loss from the home. This increase can be significant, but is typically around 3°C warmer than outside air over a heating season. This energy gain is significantly more than the energy used by the unit's motor. The tempered, filtered air is then supplied centrally to the home via the unit's outlet duct and ceiling diffuser.

Integral controls allow the **SANO PIV Loft** unit to be set to suit the individual requirements of the home. Airflow from the unit to the home is automatically regulated via an integral temperature sensor which optimises the energy benefit of the unit while ensuring that sufficient air is always supplied to help control moisture and other pollutant levels in the home.

FEATURES / BENEFITS

Discreet Small white plastic supply air diffuser which will blend well with any ceiling while distributing the air as required.

Low energy Ultra-low quiet fan/motor assembly.

Robust and lightweight Fan casing construction built to last.

Low maintenance Very large G4 grade filter.

Integral, multi-functional controls With wide airflow and temperature settings which allow the unit to be fine-tuned to suit the individual requirements of a home and its occupants. These controls include:

- 8 unit settings to choose from to suit the size, layout, thermal properties and moisture production in the home.
- Heat Recovery or Comfort Control mode function with adjustable trigger temperature setting and adjustable increased/decreased airflow setting.
- Standby mode which switches the unit off when the temperature reaches the pre-set "Standby" trigger temperature to save energy and prevent undesirable warm air being introduced unnecessarily in to the home. e.g. during hot summer days.
- Override Boost mode to operate the unit at its maximum airflow by means of a user switch.

Suspension kit and joist mounting brackets Supplied for use as required.

Warranty Each **SANO PIV Loft** has a 5 Year Warranty as standard.*



PERFORMANCE DATA

Unit Setting

The unit setting is selected by the installer to suit the size, layout, thermal properties and moisture production in the home.

Unit Setting	Normal mode Airflow (L/s)	Power Consumption** (Watts)	Max Filter Change Interval*** (Years)
1	17	2.0	10
2	21	2.5	10
3	25	3.3	9
4	29 (default)	3.8	7.5
5	33	4.1	6.5
6	37	4.6	6
7	41	5.6	5.5
8	45	6.5	5

The power consumption shown is Normal mode. *Filter change interval is indicative. High pollution and use of Override Boost mode will affect filter life.

INSTALLATION TYPES

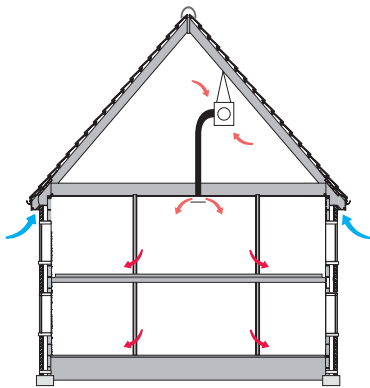

Suspended

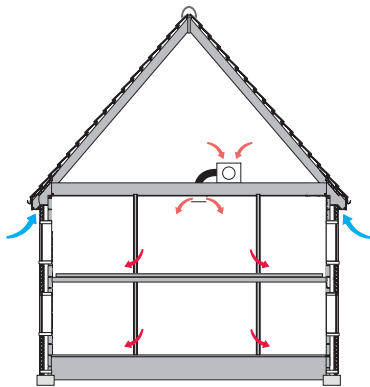

Joist Mounted

MODES

Normal

The unit will run in this mode for the vast majority of its operational time until the unit's integral temperature sensor switches it to Heat Recovery, Comfort Control or Standby mode or the Override Boost mode (if connected via a suitable switch) is activated by the occupants.

Heat Recovery

The unit will increase in speed when the loft temperature reaches the Heat Recovery trigger temperature to supply even more warmed air from the loft into the home.

Comfort Control

This mode can be selected as an alternative to Heat Recovery mode above. In this mode the unit will decrease in speed when the loft temperature reaches the Comfort Control trigger temperature reducing the amount of warm air entering the home.

Standby

The unit will essentially switch off when the loft temperature reaches the Standby trigger temperature to save energy and prevent undesirable warm air being introduced unnecessarily into the home e.g. during hot summer days. This function can be disabled if continuous running is required e.g. radon gas control.

Override Boost

The unit's automatic controls can be overridden to operate the unit at its maximum airflow by means of a user switch hard wired to the relevant connections within the unit.

DIMENSIONAL DATA

Unit in Loft

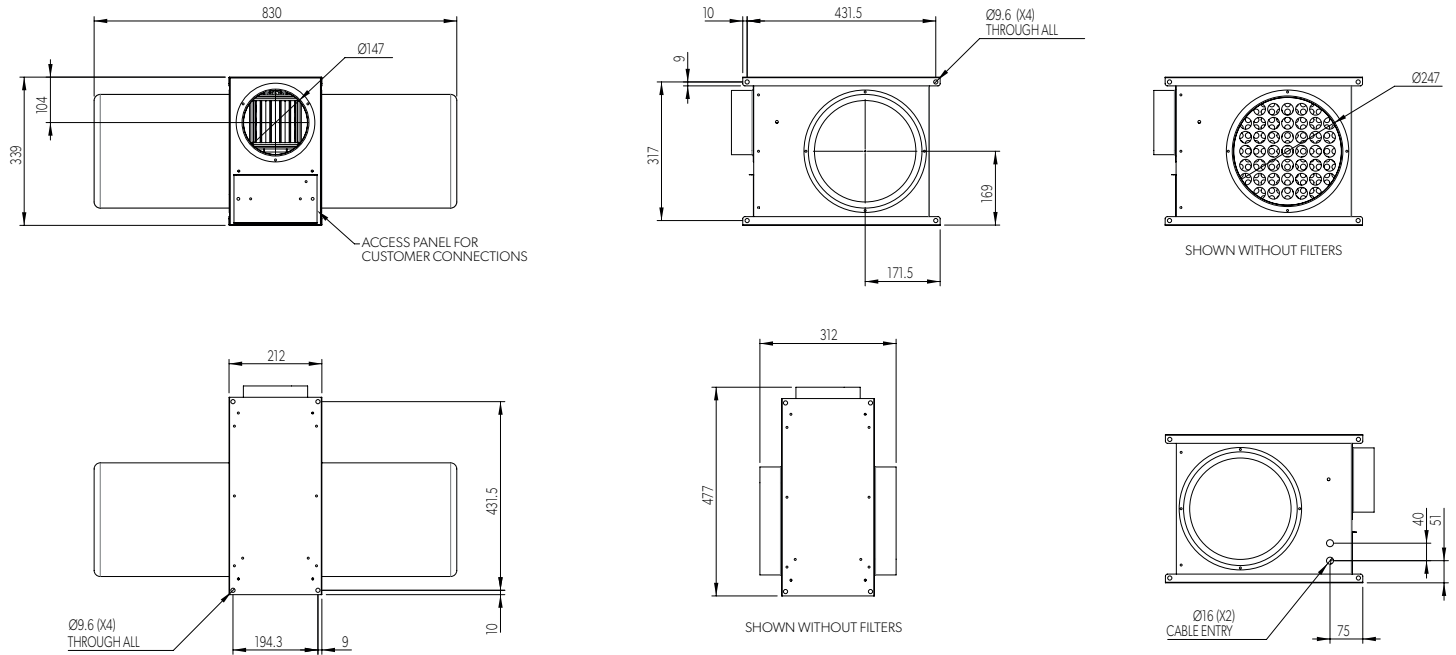

Diffuser

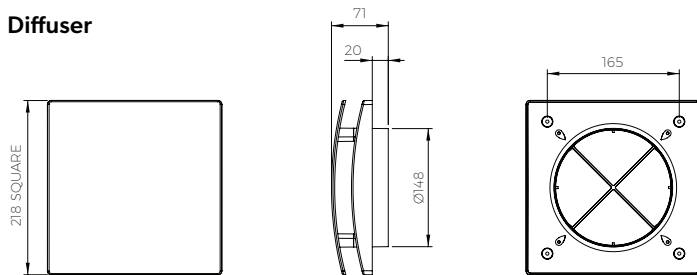

Dimensions in mm.

OPTIONAL USER CONTROL SWITCH

PIV B Switch

PIV unit airflow **Boost** enable Switch

homevent

Homevent offer a full range of ventilation services and products for new and existing homes. Our experienced staff are trained specifically to provide outstanding levels of technical competence and customer service to customers.

Tel: +44 (0) 1384 275822, **Email:** sales@homevent.co.uk

46 Third Avenue, Pensnett Trading Estate, Kingswinford, West Midlands, DY6 7US, UK

A MEMBER OF **eg** ELTA GROUP

www.homevent.co.uk

Our 5 year warranty is provided only to customers who purchased directly from us. If you purchased elsewhere then please contact them directly and they will let you know their warranty procedure. Our warranty covers repair or replacement of defective goods only. It does not cover any labour costs associated with defective product or component removal or installation, nor does it cover the cost of sending goods back to us for inspection. Our warranty is subject to storage, installation, commissioning, inspection and maintenance having been carried out in accordance with our Installation and Maintenance Instructions (supplied with each product) and which are also available to view, save or print from our website.

Homevent is a division of Elta Fans Ltd and has a policy of continuous product development and improvement and therefore reserves the right to supply products which may differ from those illustrated and described in this publication.

HV. PIV LOFT. ISSUE C. 01.04.