

GAMMA EC

Centrifugal Roof Unit

ELTA





Description

The Gamma EC of centrifugal roof mounted exhaust fans incorporates the latest state of the art, energy saving EC motor technology. They feature integrated infinitely variable speed control and eliminate the need for external VSDs, current overloads and motor phase protection.

The Gamma EC is a simple “plug and play” system which means installers do not need to have specialised control programming knowledge.

Matching sensors can easily be connected to monitor the ambient conditions in a space and provide real time feedback to the fan. The fan’s on-board microprocessor can adjust the speed and therefore modulate the ventilation rate to match the specific requirements of the area.

Models come in downflow or vertical discharge configurations and are available in 250, 315, 355, 450, 560 and 630mm fan sizes.

Typical Applications

Exhausts air from a wide range of commercial applications such as factories, warehouses and workshops, change rooms, bulk goods, retail outlets and assembly halls.

Features

- EC motor features reverse polarity protection, locked rotor protection and soft start.
- No additional protection such as contactors are required.
- All models supplied standard with 0-10V control input.
- Diameter sizes 315mm and above can be pre-configured to suit specific sensors and specific applications.
- A full range of sensors are available including differential pressure, humidity, temperature, air velocity and pollutant.
- Can be run as an independent ventilation source or integrated into most building management systems.
- Robust and lightweight construction.
- Compact, low profile design.
- Designed for downflow or vertical exhaust applications.
- Can be mounted at angles up to 30°.
- Supply air units are available.

Construction

Cowls are UV-stabilised plastic.

Impellers are backward-curved centrifugal design and are of high performance composite material.

Steel components have a corrosion resistant finish.

Bird-mesh guards are fitted as standard.

Ancillary Equipment

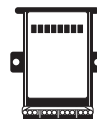

DCV-CU - Premium Module on-board control pack

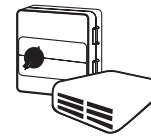

Controllers & Sensors

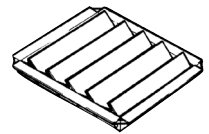

CBD - Backdraft shutter

Motor

Type - electronic commutated (EC) motor.

Electricity supply - 200-277V single-phase, 50/60Hz for 250 to 450mm sizes.

- 380-480V three-phase, 50/60Hz for 560 and 630mm sizes.

Ball Bearing - sealed for life.

Integrated EC-Controller providing infinite speed control.

Internal Thermal Protection

Integral thermal overload protection is supplied as standard.

Testing

Airflow tests to ISO 5801:2007.

Noise tests to ISO 3744:2010.

Additional Information

Diameter sizes from 315mm and above can be pre-configured to suit specific sensors and specific applications. Please advise Elta of these parameters at the time of order.

EC motors should be directly connected to their appropriate AC supply. EC motors should not be regularly power cycled.

How To Order

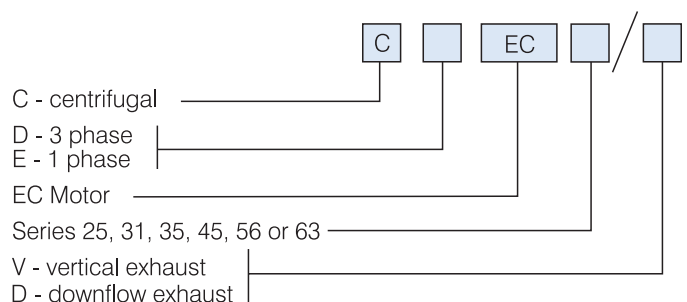

Dimensions

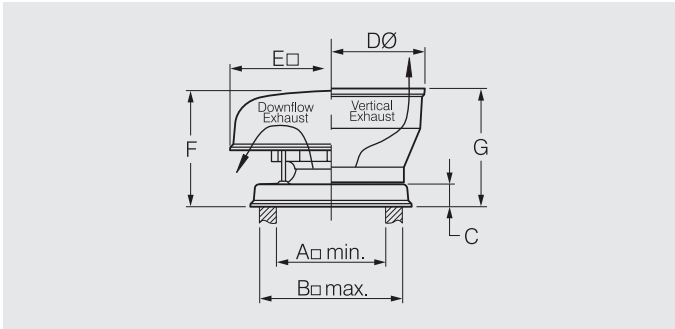

Model	Dimensions, mm							App. weight	App. Vol.
CDEC..	A	B	C	DØ	E	F	G	kg	m ³
25	260	310	50	430	370	200	244	6	0.05
31	310	410	75	500	575	330	334	11	0.13
35	400	500	75	640	670	410	417	14	0.22
45	620	720	75	908	890	530	540	28	0.52
56	620	720	75	908	890	530	540	32	0.52
63	710	810	75	1260	1180	650	695	46	1.28

Backdraft Damper Losses

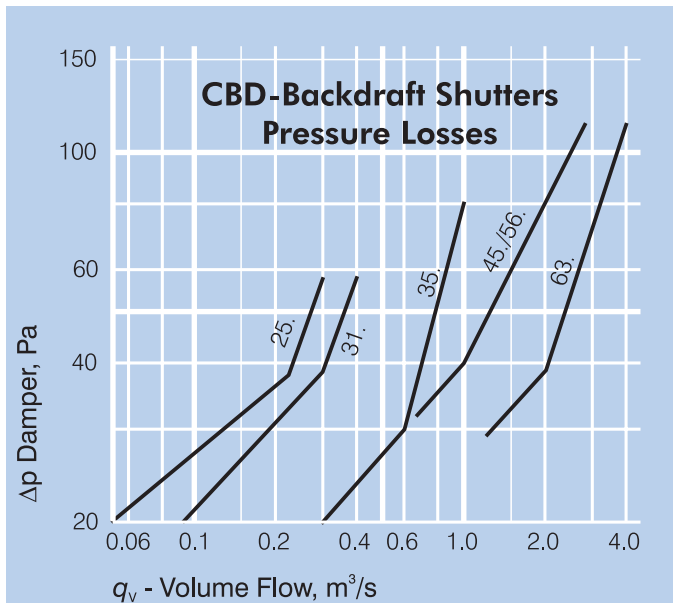

Additional Information:

If dampers are fitted the pressure loss through them must be added to the system resistance before selecting the fan.

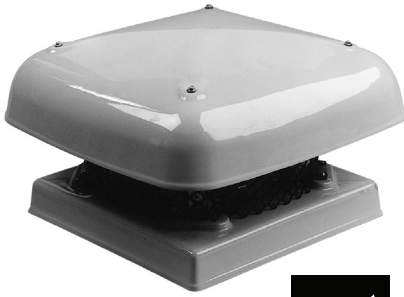

Suggested Specification

Downflow Exhaust

The roof ventilators shall be of the Gamma EC Series downflow exhaust type as designed and manufactured by Elta and be of the model numbers shown on the schedule/drawings.

Impellers shall be made from high performance composite material. They shall be backward-curved centrifugal design and driven by EC external rotor motors with integrated EC Controller and integral thermal overload protection. Diameter sizes from 315mm and above shall be pre-configured to suit the selected sensors and the required applications.

The cowls shall be of the downflow exhaust design and manufactured from UV-stabilised plastic. Steel components shall be corrosion protected.

All models shall be fully tested as a complete assembled unit to ISO5801:2007 for airflow and ISO 3744:2010 for noise.

Technical Data

Model CDEC...D CEEC...D	Percentage of full speed (%)	*Max. Fan Speed r/s	Airflow @ 0Pa m ³ /s	Avg. dB(A) @ 3m	CEEC.. kW	1ph. Amps	CDEC.. kW	3ph Amps
25	100	55	0.44	60	0.21	1.50	-	-
	80	44	0.39	59	0.15	1.20	-	-
	60	33	0.29	53	0.07	0.50	-	-
	40	22	0.20	43	0.03	0.22	-	-
	20	11	0.11	26	0.01	0.10	-	-
31	100	34	0.80	61	0.30	1.90	-	-
	80	27	0.63	56	0.16	0.98	-	-
	60	20	0.48	49	0.07	0.49	-	-
	40	13	0.32	39	0.03	0.23	-	-
	20	7	0.16	22	0.01	0.12	-	-
35	100	27	0.82	56	0.28	1.70	-	-
	80	21	0.66	51	0.14	0.92	-	-
	60	16	0.48	44	0.06	0.45	-	-
	40	11	0.32	35	0.03	0.21	-	-
	20	5	0.16	19	0.01	0.13	-	-
45	100	24	1.48	60	0.60	2.90	-	-
	80	19	1.18	54	0.31	2.00	-	-
	60	14	0.89	47	0.14	0.89	-	-
	40	10	0.60	38	0.05	0.55	-	-
	20	5	0.30	21	0.02	0.34	-	-
56	100	21	2.77	62	-	-	1.11	2.40
	80	16	2.18	56	-	-	0.58	1.30
	60	12	1.63	49	-	-	0.25	0.72
	40	8	1.09	39	-	-	0.09	0.38
	20	4	0.53	23	-	-	0.02	0.20
63	100	21	3.72	68	-	-	1.85	4.00
	80	16	2.93	62	-	-	0.96	2.00
	60	12	2.21	54	-	-	0.47	1.00
	40	8	1.48	44	-	-	0.14	0.52
	20	4	0.73	27	-	-	0.04	0.25

* The fan will maintain the set speed whether run on 50 or 60Hz supply.

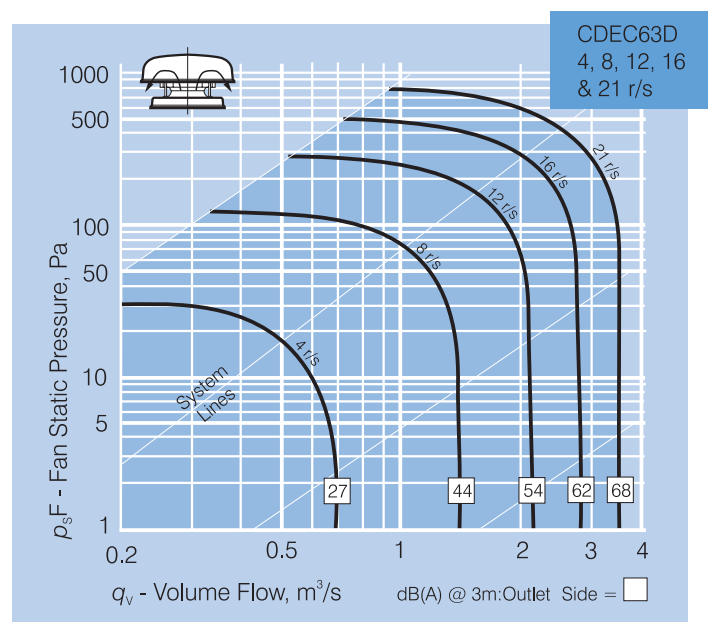
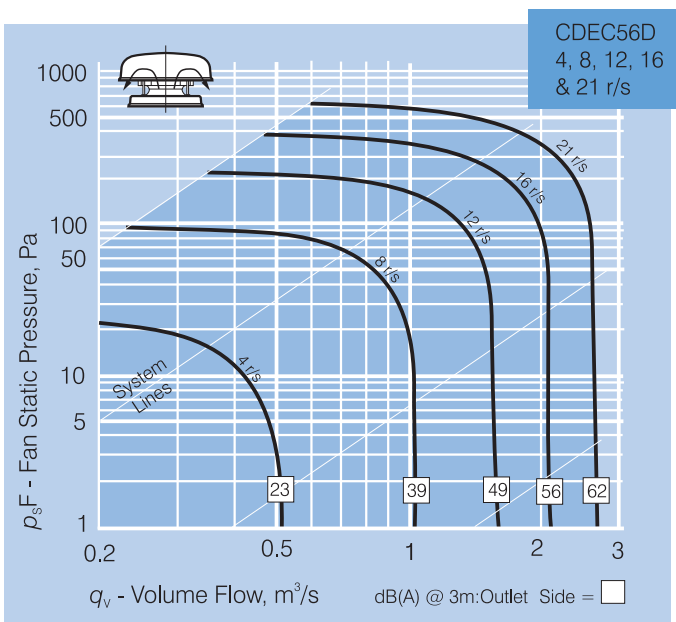
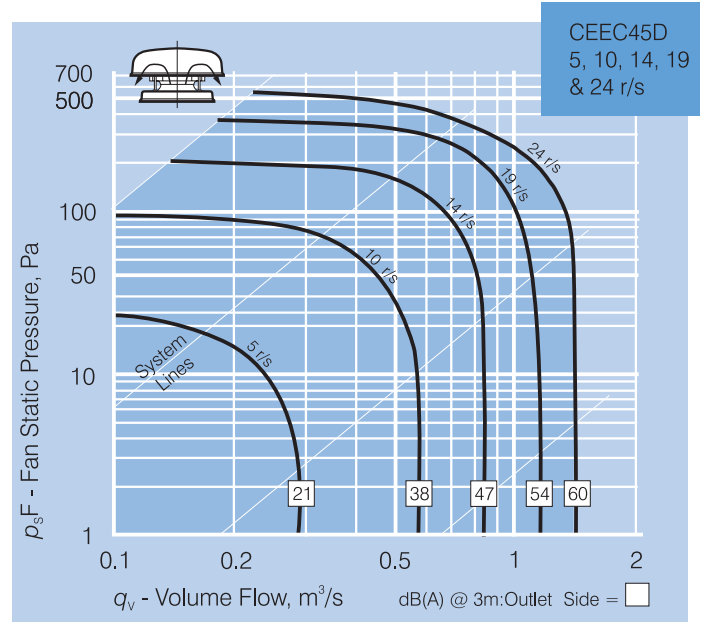
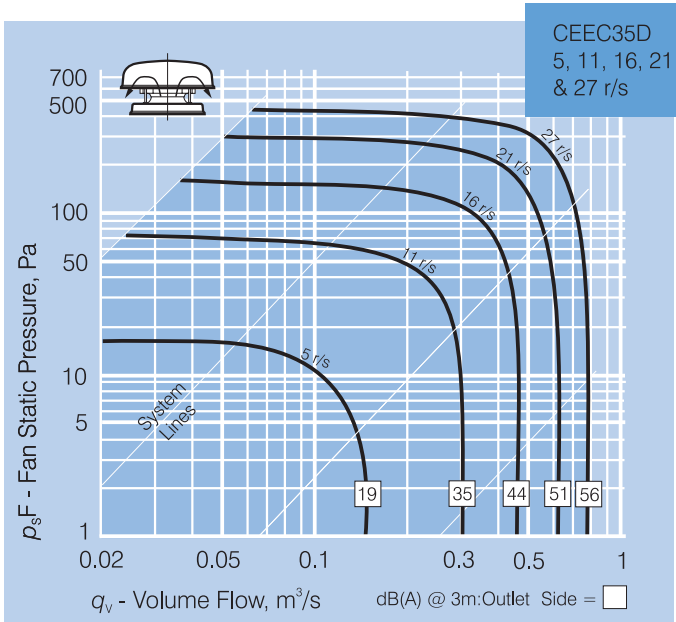
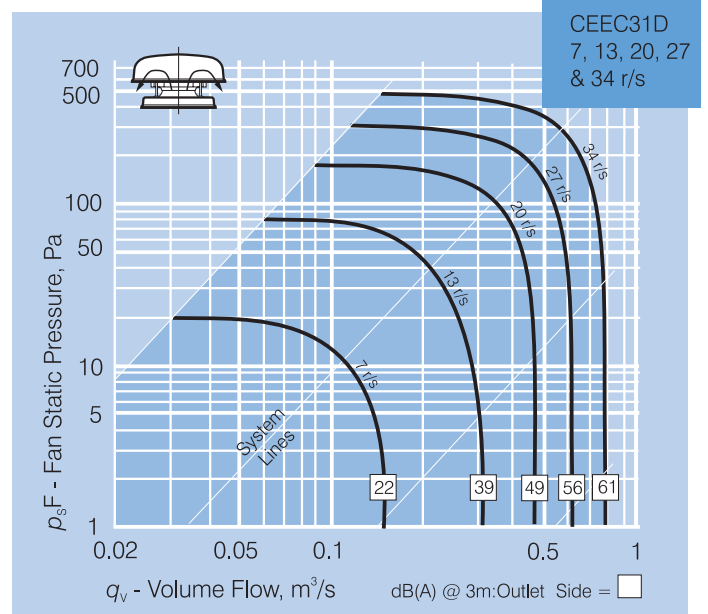
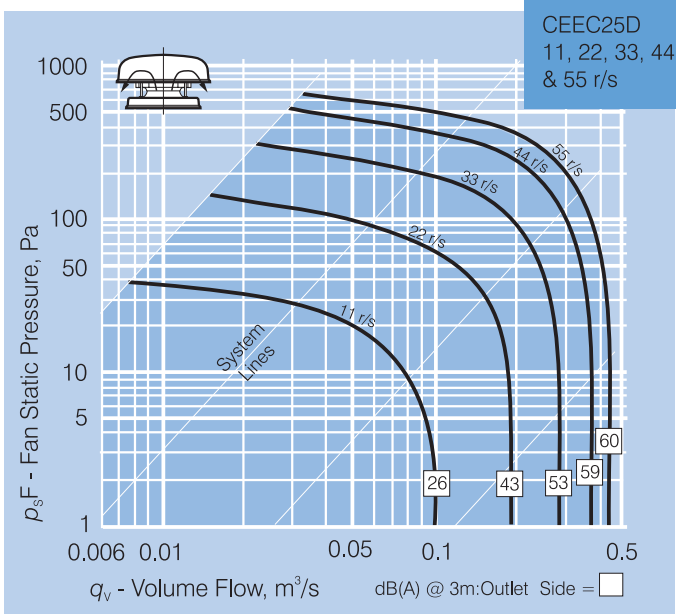



Suggested Specification

Vertical Exhaust

The roof ventilators shall be of the Gamma EC Series vertical exhaust type as designed and manufactured by Elta and be of the model numbers shown on the schedule/drawings.

Impellers shall be made from high performance composite material. They shall be backward-curved centrifugal design and driven by EC external rotor motors with integrated EC Controller and integral thermal overload protection. Diameter sizes from 315mm and above shall be pre-configured to suit the selected sensors and the required applications.

The windband shall be of the vertical exhaust design and manufactured from UV-stabilised plastic. Steel components shall be corrosion protected.

All models shall be fully tested as a complete assembled unit to ISO5801:2007 for airflow and ISO 3744:2010 for noise.

Technical Data

Model CDEC...V CEEC...V	Percentage of full speed (%)	*Max. Fan Speed r/s	Airflow @ 0Pa m ³ /s	Avg. dB(A) @ 3m	CEEC.. kW	1ph. Amps	CDEC.. kW	3ph Amps
25	100	55	0.42	64	0.22	1.65	-	-
	80	44	0.37	63	0.15	1.20	-	-
	60	33	0.28	54	0.07	0.55	-	-
	40	22	0.18	45	0.03	0.22	-	-
	20	11	0.10	28	0.01	0.12	-	-
31	100	34	0.73	62	0.32	1.80	-	-
	80	27	0.58	56	0.16	0.97	-	-
	60	20	0.42	49	0.08	0.48	-	-
	40	13	0.29	40	0.03	0.22	-	-
	20	7	0.14	23	0.01	0.12	-	-
35	100	27	0.76	56	0.26	1.50	-	-
	80	21	0.61	50	0.13	0.82	-	-
	60	16	0.46	44	0.07	0.42	-	-
	40	11	0.30	34	0.03	0.20	-	-
	20	5	0.15	18	0.01	0.12	-	-
45	100	24	1.38	56	0.59	2.90	-	-
	80	19	1.11	51	0.31	1.90	-	-
	60	14	0.82	45	0.15	0.85	-	-
	40	10	0.55	36	0.05	0.56	-	-
	20	5	0.27	21	0.15	0.34	-	-
56	100	21	2.40	64	-	-	1.28	2.30
	80	16	1.89	58	-	-	0.65	1.30
	60	12	1.42	51	-	-	0.29	0.71
	40	8	0.94	41	-	-	0.10	0.36
	20	4	0.47	24	-	-	0.02	0.20
63	100	21	3.47	67	-	-	1.94	3.90
	80	16	2.75	61	-	-	0.96	2.00
	60	12	2.05	55	-	-	0.44	1.00
	40	8	1.39	45	-	-	0.14	0.51
	20	4	0.63	28	-	-	0.04	0.24

* The fan will maintain the set speed whether run on 50 or 60Hz supply.

GAMMA EC

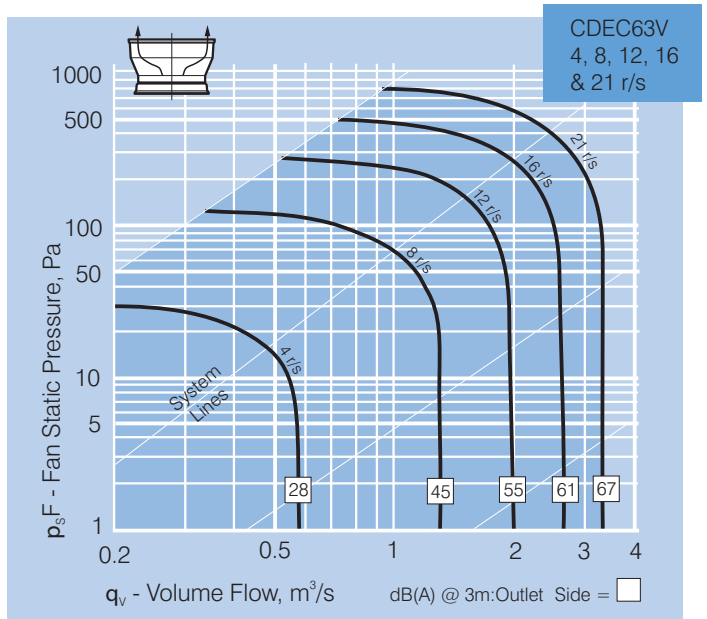
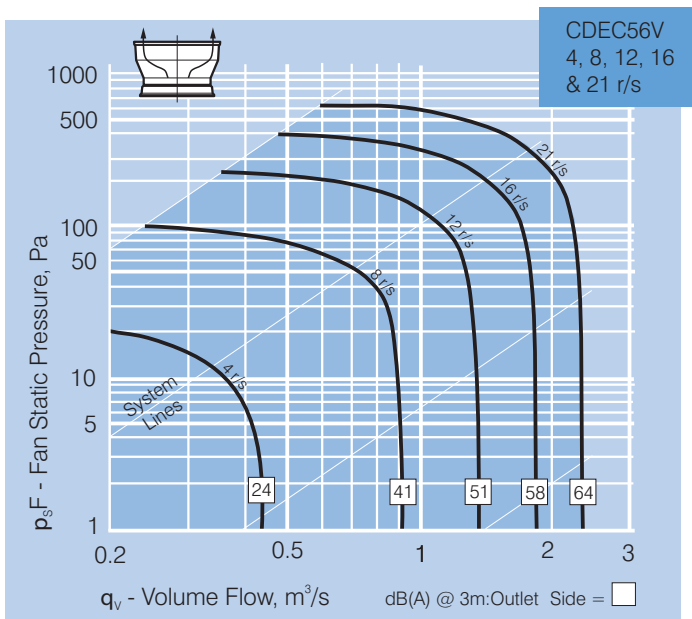
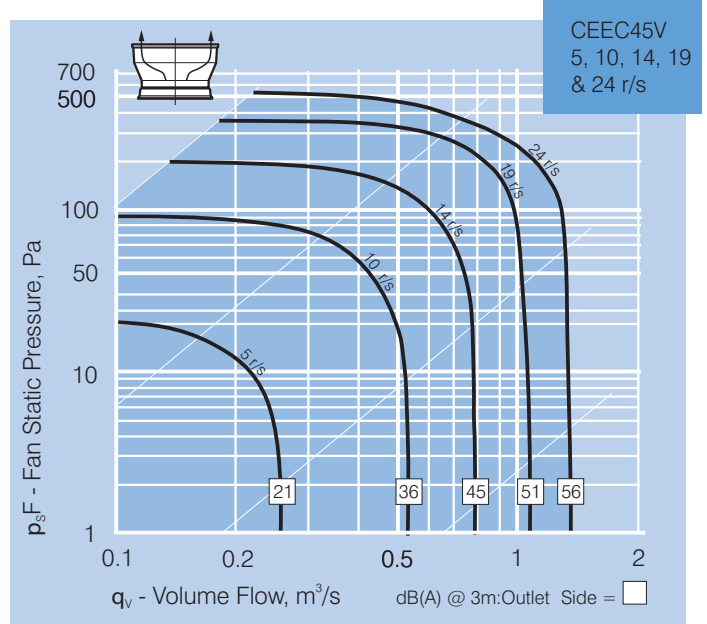
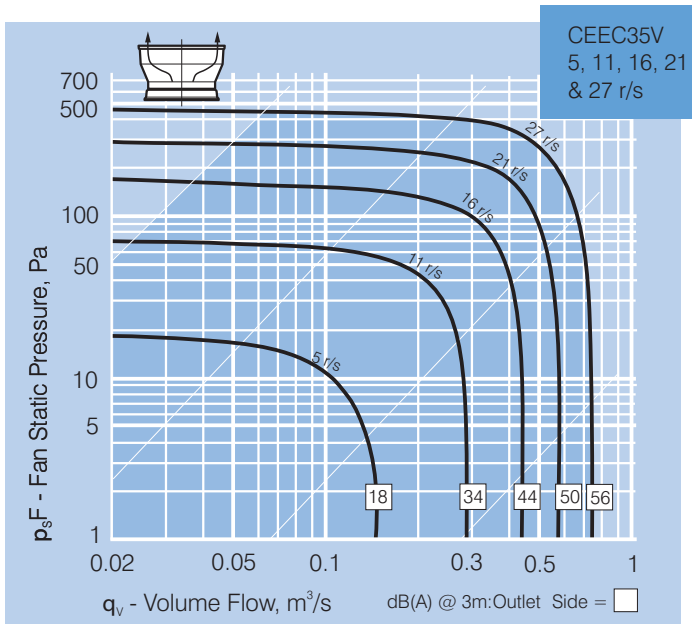
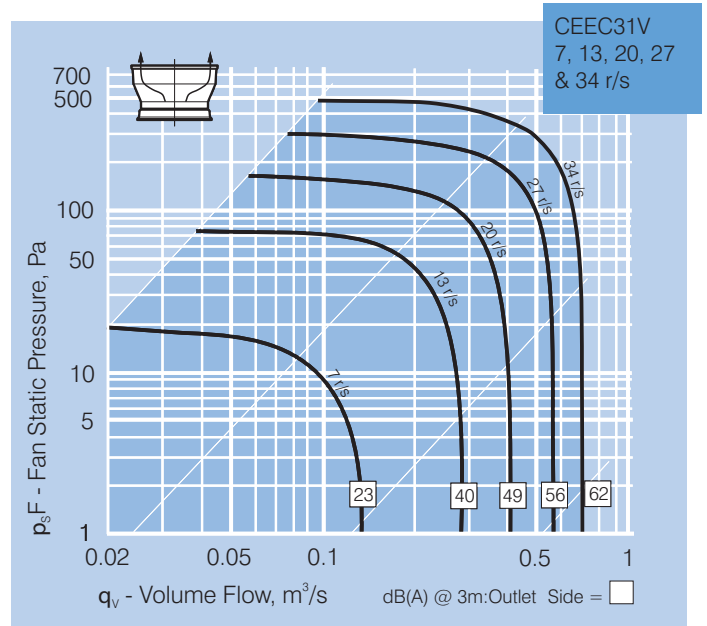
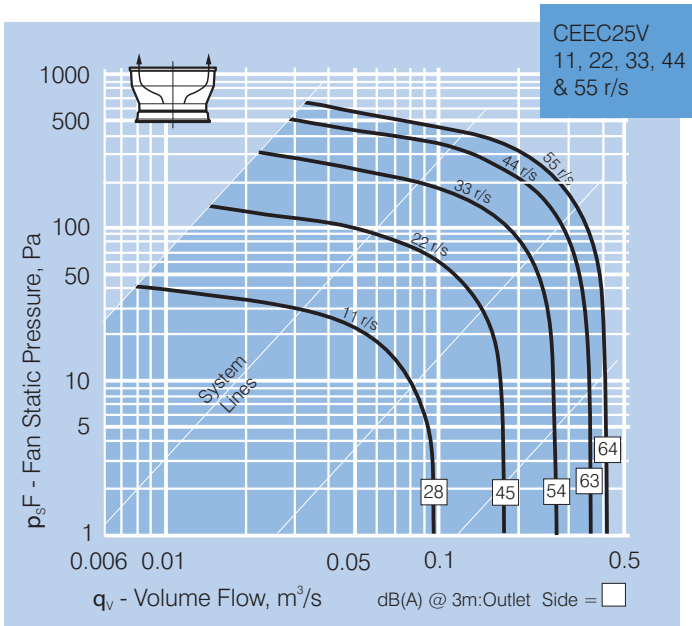



Elta Asia Sdn Bhd

Tel **+603 7846 0340**
Email **info@elta.asia**

elta.asia

GEC-05-2026 Issue A



FS 676456

A MEMBER OF  ELTA GROUP