

# COMPACT FLAMEPROOF SQUARE PLATE

**ELTA**

Flameproof Axial Flow Fan

---



# COMPACT FLAMEPROOF SQUARE PLATE

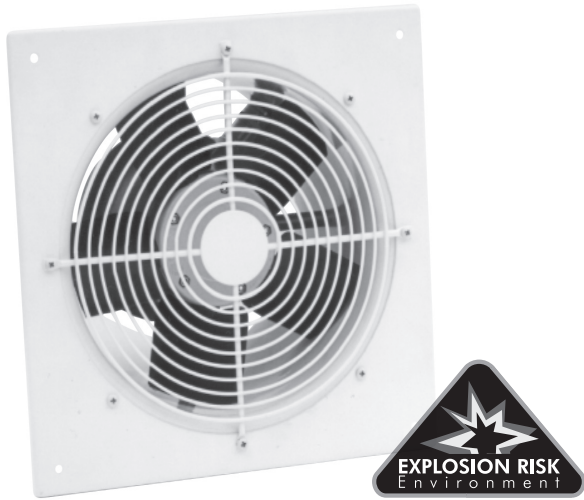

## Description

The Compact Flameproof Square Plate fan has been specifically designed to meet the needs of small ventilation applications in hazardous or explosive environments. They are ideal for wall mounting but can be mounted at any angle and on the ceiling if required.

There are 4 sizes in the range extending from 250 to 400mm diameter.

### Typical Applications

Elta's Compact Flameproof fans can be used to exhaust in areas where the environment has been defined as being hazardous or explosive necessitating the use of flameproof motors. These areas include spray booths and battery charge rooms.

These products are suitable for all Group II hazardous gas environments **EXCEPT** for the following:

- Where the ambient temperature is less than -20°C or greater than 40°C.
- Where the fan is exhausting from the vapour space of a tank or vessel (Zone 0).
- Where the fan is exhausting immediately adjacent to a continuous source of release (Zone 0).
- In mines susceptible to fire damp.
- Where special conditions exist such as corrosion, water, dust, vibration or high level of UV exist.

### Features

- Robust galvanised steel square plate with white powder-coated finish.
- Fan blades are anti-static GRP.
- Fitted with high strength guards to reduce the risk of objects entering fan.
- Designed for single phase power supply.
- Motor comply with Ex d, Group II, Zone 1, T6 protection - See Additional Information.
- IP66 rated.

### Construction

Galvanised steel square plate with a white powder-coated finish. Axial impellers have glass reinforced anti-static blades.

### Motor

Type - squirrel cage induction motor.

Electricity Supply - 230V, single phase, 50Hz.

Ball Bearing - sealed for life.

Maximum ambient temperature is 40°C.

These motors are not speed-controllable.

### Internal Thermal Protection

The motor is fitted with thermal protection to conform to the requirements of AS1359. IECEx certification and classification of T6 does not take into account abnormal operation such as locked rotor where the temperature of the surfaces may exceed 85°C. If this is an issue with your application, further protection should be fitted.

### Testing

Airflow tests to ISO5801:1997, Type 'A' Installation (free inlet and outlet).

Noise tests to BS848:Part 2, 1985.

### Additional Information

These products have a **Certificate of Conformity issued under the IEC Ex Certification Scheme for Explosion Protected Electrical Equipment.**

This certificate, number IEC Ex TSA 14.0024X, covers these fans for Ex d Group II, Zone 1 protection. These fans are approved for gas groups IIA, IIB and IIC, have temperature classification T6 and enclosure protection IP66.

## Suggested Specification

The fans shall be of the Compact Flameproof Square Plate Fan, as designed and manufactured by Elta and shall be of the model numbers shown on the schedule/drawings.

They shall be approved for gas Groups IIA, IIB and IIC, have temperature classification T6 and enclosure protection IP66.

They shall have a galvanised steel square plate with a white powder-coated finish and be fitted with glass reinforced anti-static blades.

All data shall be based on tests to ISO5801:1997, Type 'A' Installation for airflow and to BS848:Part 2, 1985 for noise.

## How To Order

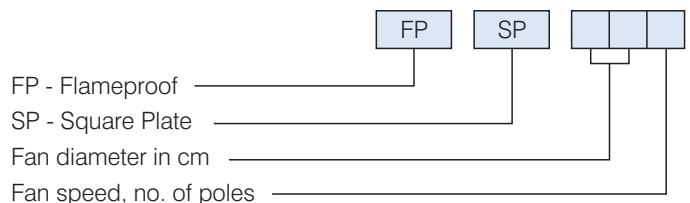

# COMPACT FLAMEPROOF SQUARE PLATE

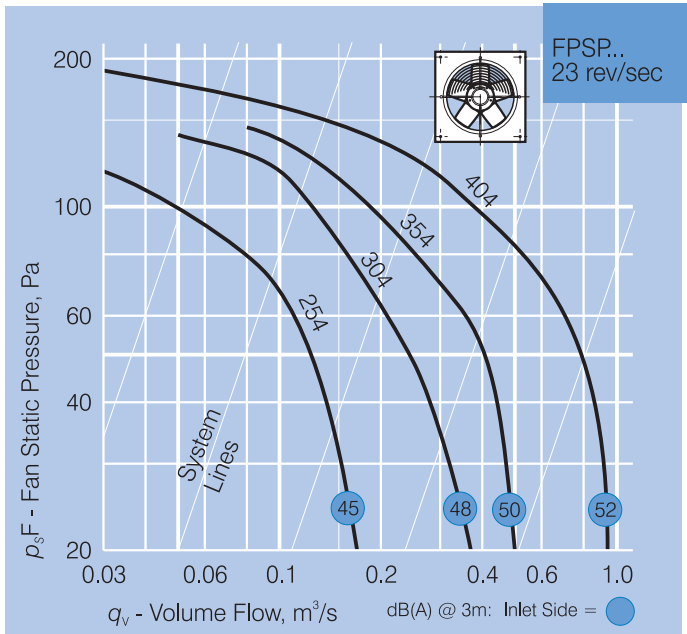

## Technical Data

Model FPSP...	Fan Speed rev/sec	Avg dB(A) @ 3m	FPSP.. 1 ph. Watts	Approx. Amps	Approx. wt. kg
254	23	45	120	1	12
304	23	48	120	1	13
354	23	50	120	1	14
404	23	52	120	1	16

## Noise Data

Model FPSP...		In-duct Sound Power Levels L <sub>w</sub> dB re 1pW							
		63	125	250	500	1k	2k	4k	8k
254	Inlet	66	72	70	63	57	54	57	38
304	Inlet	66	78	68	67	61	58	54	48
354	Inlet	67	80	71	66	62	61	57	51
404	Inlet	72	72	68	66	69	67	63	50

Sound Power Levels at 50% of peak pressure and on the Inlet Side of the unit.

## Dimensions

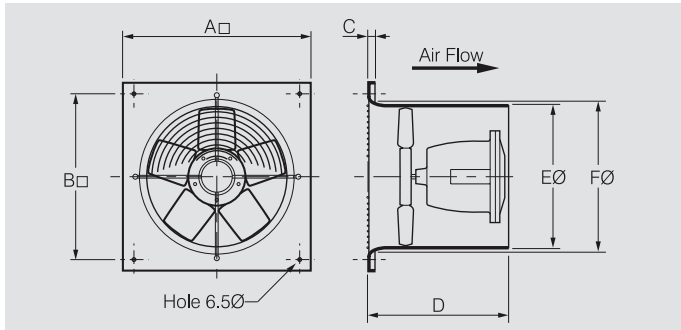

Model FPSP...	Dimensions, mm					
	A□	B□	C	D	EØ	FØ
254	340	300	12	252	262	264
304	420	380	12	252	313	325
354	480	440	12	252	363	375
404	540	490	12	252	410	420



Elta Asia Sdn Bhd

Tel **+603 7846 0340**

Email **info@elta.asia**

**elta.asia**

CFSP-2026 Issue A



FS 676456

A MEMBER OF  ELTA GROUP