

COMPACT 2000 EC

Square Plate EC Axial Fan

ELTA

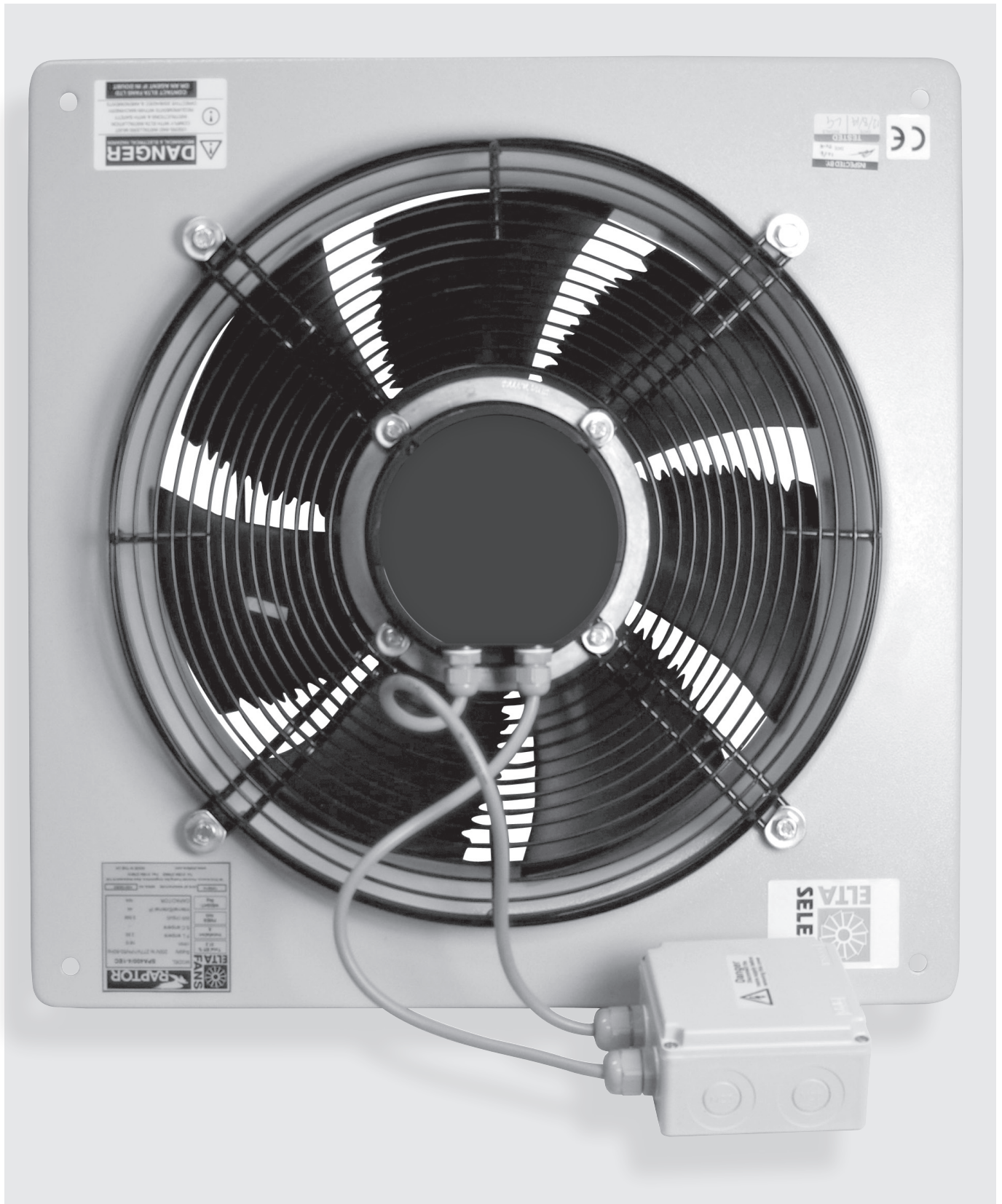

COMPACT 2000 EC



Description

The Compact 2000 EC of square plate axial fans incorporates the latest state of the art EC motor technology. They feature integrated infinitely variable speed control and eliminate the need for external VSDs, current overloads and motor phase protection. They are an energy saving solution and are most efficient when airflow requirements vary during the course of the day.

Optional matching sensors monitor the conditions and provide real time feedback to the fan's on-board electronics.

This processes the data and in turn adjusts the motor speed. This modulates the ventilation rate to match the specific requirements of the area.

The Compact 2000 EC fans are a simple "plug and play" system which means installers do not need to have specialised control programming knowledge. The series is available in 4 sizes ranging from 250 to 630mm diameter.

Typical Applications

Suitable for general ventilation applications in commercial and light industrial environment such as switch rooms, data centres, food storage, substations and cleanroom applications.

Features

- EC motor features reverse polarity protection, locked rotor protection and soft start.
- No additional protection such as current overloads are required.
- All models supplied standard with 0-10V control input. Diameter sizes 500mm and above can be pre-programmed to suit specific sensors and specific applications.
- A full range of sensors are available including differential pressure, humidity, temperature, air velocity and pollutant.
- Can be run as an independent ventilation source or integrated into most building management systems.
- Robust galvanised steel construction with polyester epoxy finish.
- Low noise, high performance impellers with enhanced aerodynamic design.
- Guard is incorporated as standard.
- Units are light weight and can be mounted at any angle.
- Capable of operating at temperatures up to 70°C.

Construction

The square plate is manufactured from galvanised steel with a high quality polyester epoxy finish as standard.

Impellers are of high performance composite material.

Motor

Type - electronic commutated (EC) motor.

Electricity supply - 200-277V single phase, 50/60Hz or 380-480V three-phase, 50/60Hz

Ball Bearing - sealed for life.

Integrated EC-Controller providing infinite speed control.

IP44 rating.

Internal Thermal Protection

Integral thermal overload protection is supplied as standard.

Testing

Airflow tests to ISO5801:2007

Noise tests to BS848:Part 2, 1985

Additional Information

Diameter sizes from 500mm and above can be pre-programmed to suit specific sensors and specific applications. Please advise Elta of these parameters at the time of order.

EC motors should be directly connected to their appropriate AC supply. EC motors should not be regularly power cycled.

Suggested Specification

The square plate wall mounted axial fans shall be of the Compact 2000 EC Series as designed and manufactured by Elta and be of the model numbers shown on the schedule/drawings.

The axial impellers shall be made from high performance composite material. They shall be driven by an EC-DC external rotor motor with integrated EC-Controller and integral thermal protection. Diameter sizes from 500mm and above shall be pre-programmed to suit the selected sensors and the required applications. Square plates shall be galvanised steel with a polyester epoxy finish.

All models shall be fully tested to ISO5801:2007 for airflow and to BS848:Part 2, 1985 for noise.

How To Order

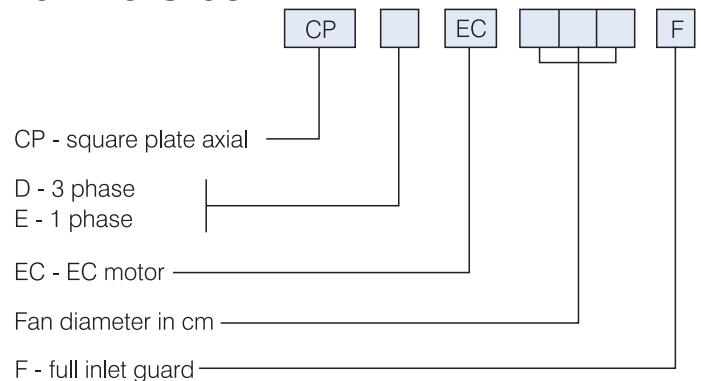

Ancillary Equipment



DCV-CU - Premium Module on-board control pack

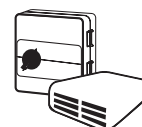

Controllers & Sensors



Backdraft shutters



DG - Finger Guards

COMPACT 2000 EC

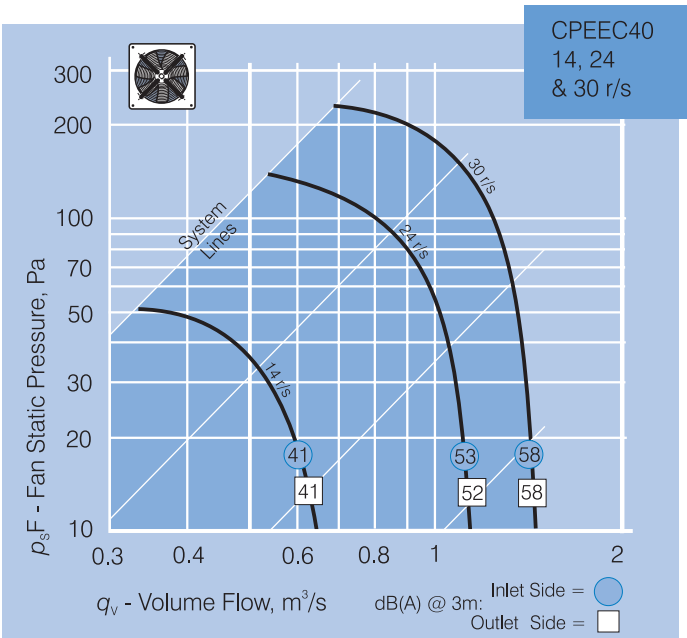
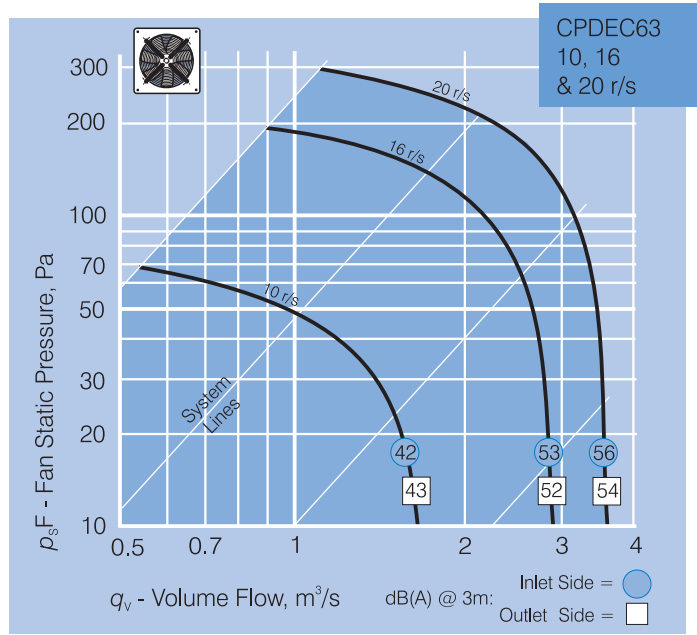
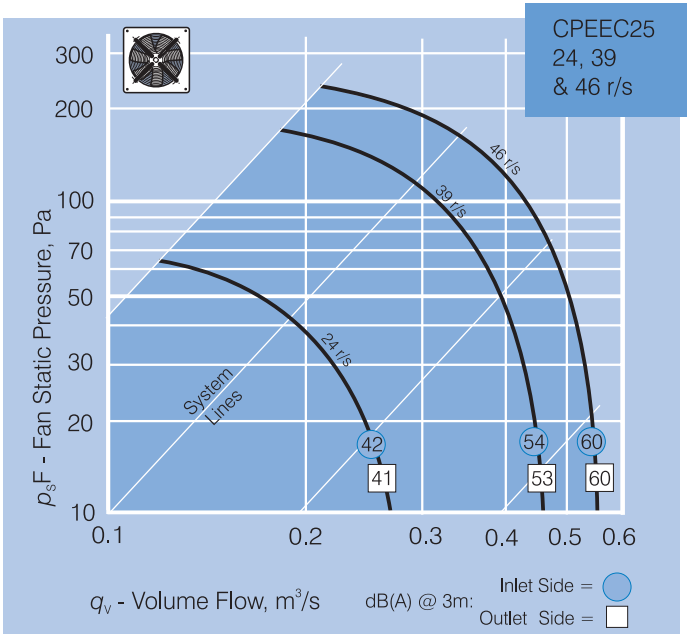

Dimensions

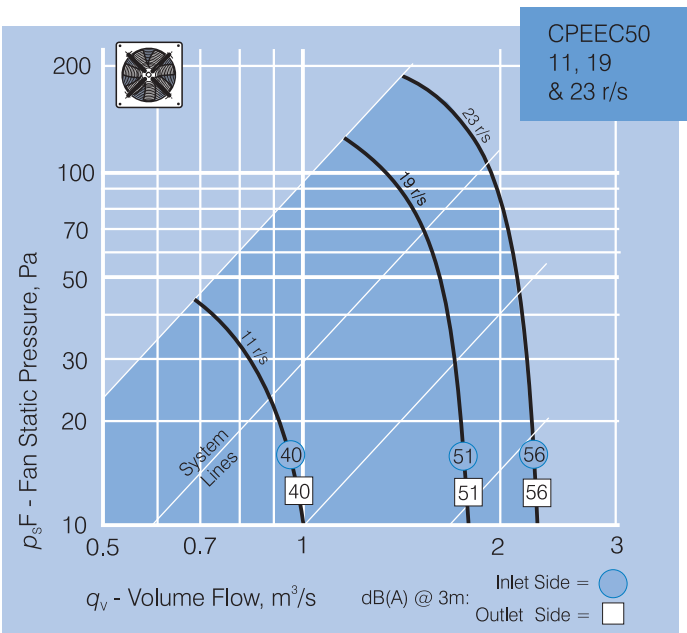
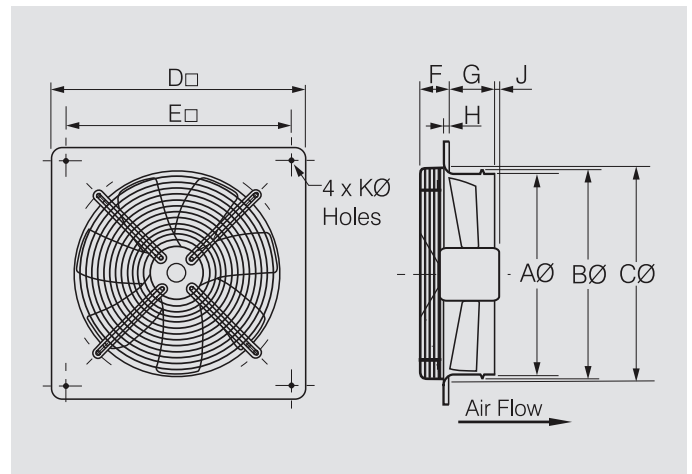

Model	Dimensions, mm										App. wt.	App. vol.
CPDEC..	AØ	BØ	CØ	D□	E□	F	G	H	J	KØ	kg	m ³
CPEEC..												
25.	254	257	276	370	320	43	48	6	24	7	4.5	0.03
40.	400	412	450	540	490	56	95	15	-	10	9.5	0.07
50.	540	517	584	655	615	63	104	16	37	11	21.0	0.13
63.	635	648	728	805	750	80	130	20	53	11	38.5	0.22

COMPACT 2000 EC

Model CPDEC.. CPEEC..	Percentage of full speed (%)	Max. Fan Speed rev/sec*	Airflow @ 0Pa m ³ /s	Avg. dB(A) @ 3m		CPEEC.. 1ph. kW	Amps	CPDEC.. 3ph. kW	Amps
				Inlet	Outlet				
25	100	46	0.56	60	60	0.24	1.88	-	-
	80	39	0.47	54	53	0.14	1.13	-	-
	50	24	0.29	42	41	0.04	0.33	-	-
	20	8	0.18	20	20	0.01	0.08	-	-
40	100	30	1.47	58	58	0.56	2.50	-	-
	80	24	1.16	53	52	0.27	1.29	-	-
	50	14	0.70	41	41	0.07	0.38	-	-
	20	5	0.21	20	20	0.01	0.11	-	-
50	100	23	2.32	56	56	0.77	3.46	-	-
	80	19	1.85	51	51	0.41	1.90	-	-
	50	11	1.07	40	40	0.10	0.49	-	-
	20	4	0.32	20	20	0.03	0.23	-	-
63	100	20	3.65	56	54	-	-	1.30	2.03
	80	16	2.94	53	52	-	-	0.69	1.18
	50	10	1.75	42	43	-	-	0.16	0.43
	20	3	0.66	20	20	-	-	0.02	0.17

* The fan will maintain the set speed whether run on 50 or 60Hz supply.



Elta Asia Sdn Bhd

Tel +603 7846 0340
Email info@elta.asia

elta.asia

C2EC-05-2026 Issue A



FS 676456