

# COMPACT COOLER

Portable Cooling Fan

---

**ELTA**



# COMPACT COOLER

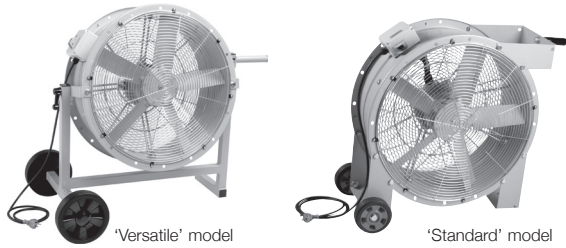

## Description

The Compact Cooler of portable fans is designed to increase comfort and lift productivity by providing relief for people working in warm to hot locations. They deliver large volumes of air and include wheels and handles to ensure easy manoeuvrability.

There are 2 models, the 'Versatile', which incorporates a tilting facility and the more economical 'Standard' model which fits into more confined spaces.

### Typical Applications

Designed to provide relief in many locations including marquees, club rooms, shops, restaurants, gymnasiums schools, foundries, workshops and warehouses.

### Features

- Versatile models can be tilted up or down to direct air where it is needed most.
- Built-in wheels and handle make them easy to manoeuvre.
- Compact, slim design allows operation and storage in limited spaces.
- Conveniently passes through a standard doorway.
- Improves people's comfort level and productivity in hot conditions.
- Can also be used for cooling equipment and products quickly and efficiently.
- Efficient and quiet aerofoil axial flow impeller.
- Operating temperature ranges from -20 °C to +70 °C.
- Weatherproof switch fitted as standard.
- Heavy duty plug and lead supplied.
- Safety guards comply with AS4024.1:1996.
- Mising Kit can be added for adding cooling (FMK3, FMK5 & FMK7).

### Construction

Frame is powder-coated square hollow section steel tube.

Fan casing is polyester epoxy coated, galvanised steel.

Intake and discharge safety guards are fitted as standard.

### Motor

Type - squirrel cage induction motor.

Electricity supply - 220-240V, single-phase, 50Hz; three-phase available on request.

Ball Bearing - sealed for life.

Weatherproof to IP55.

Operating temperature range: -20 °C to +70 °C.

### Internal thermal Protection

Replaceable fuse fitted as standard (For single phase models only)

### Wiring Diagram

Not required. Fan fitted with weatherproof ON-OFF switch and heavy duty plug and lead.

## Dimensions

### Versatile, CCE404 & CCE564

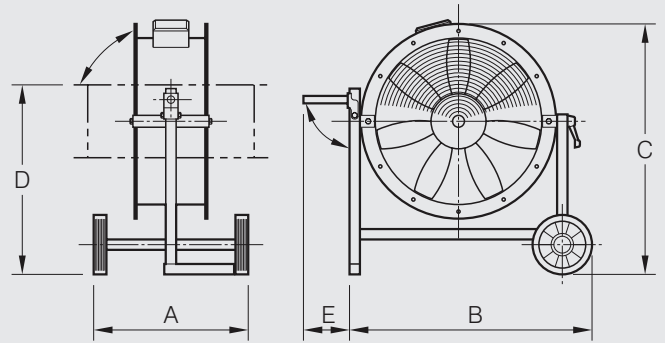

### Standard, CCS564

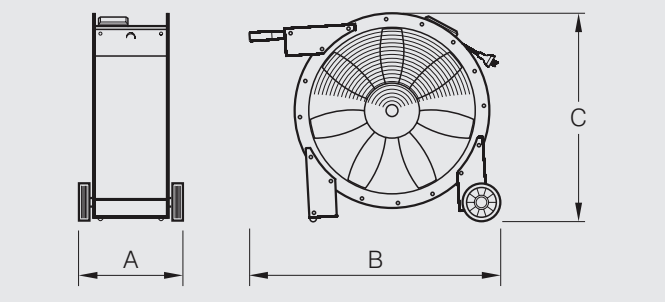

Model Number	Dimensions, mm					Weight, kg
	A	B	C	D	E	
CCE404	440	615	745	585	150	21
CCE564	540	820	845	640	150	40
CCS564	348	822	683	-	-	26

## Technical Data

Model Number	Airflow m <sup>3</sup> /s	Fan Speed rev/sec	Avg dB(A) @ 3m	CCE/S.. 1 ph. kW	1 ph. Amps
CCE404	1.45	24	47	0.25	1.80
CCE564	3.42	24	58	0.75	4.90
CCS564	3.42	24	58	0.75	4.90

## Suggested Specification

The cooling fans shall be of the Compact Cooler as designed and manufactured by Elta and be of the model numbers shown on the schedule/drawings.

Intake and discharge safety guards shall comply with AS4024.1:1996 and the fitted weatherproof switch will be rated at IP55.

Fan casing shall be manufactured from galvanised steel and finished in polyester epoxy coating.

## How To Order

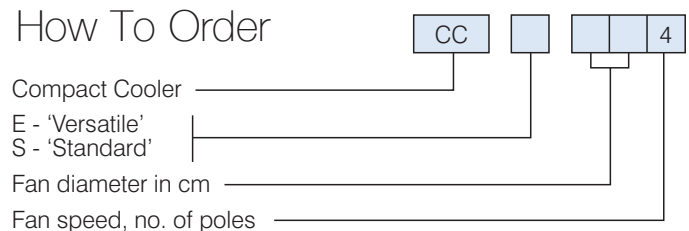





Elta Asia Sdn Bhd

Tel **+603 7846 0340**

Email **info@elta.asia**

**elta.asia**

CC-2026 Issue A



FS 676456

A MEMBER OF  ELTA GROUP