

GAMMA SUPPLY

Centrifugal Supply Air Roof Units

ELTA



GAMMA SUPPLY



Description

The Gamma centrifugal supply air roof units have been designed for use in free intake and ducted installations.

These compact and low profile units are ideal for supplying fresh air to an air handling unit or to an air conditioning system in commercial buildings.

They are available in 8 sizes extending from 315 to 710mm diameter.

Typical Applications

Supplying fresh air to an air handling unit or to an air conditioning system in commercial buildings. Also suitable where make-up air or positive pressure is required in the ventilated space.

Features

- Corrosion-proof, robust construction.
- Choice of speeds available.
- Ideal for ducted installations.
- Fitted bird mesh prevents debris and birds entering building and interrupting motor operation.
- High performance backward-curved centrifugal impellers fitted.
- Can be mounted at angles up to 30°.
- Some 3-phase motors are 2-speed star/delta design as standard.
- Speed-controllable using electronic or auto-transformer controllers.
- Available as axial supply air units.

Construction

Cowls are of UV-stabilised plastic.

Steel components have a corrosion resistant finish.

Backward-curved centrifugal impellers.

Bird-mesh guards are fitted as standard.

Shutters cannot be fitted.

Motor

Type - external rotor, squirrel cage induction motors.

Electricity supply - 230V, single and 415V, 3-phase, 50Hz.

Ball Bearing - sealed for life.

Speed-controllable using electronic or auto-transformer controllers.

Some three-phase units are fitted with 2-speed star/delta design motors.

Internal Thermal Protection

All motors are fitted with Internal Thermal Contacts as standard.

Testing

Airflow tests to BS848:Part 1, 1980

Noise tests to BS848:Part 2, 1985

Dimensions

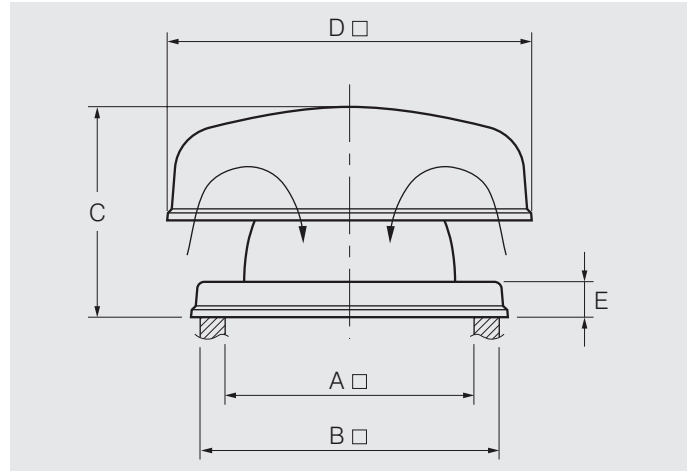

Model Number	Dimensions, mm					Approx. weight kg.	Approx. volume m ³
CD.. CE..	A□	B□	C	D	E		
31.S	480	580	420	670	50	9	0.23
35.S	590	690	535	890	50	20	0.50
40.S						22	
45.S	740	840	670	1180	90	32	1.10
50.S						36	
56.S	805	905	690	1395	50	40	1.60
63.S	1040	1140	950	1640	50	67	3.0
71.S						70	

Suggested Specification

The roof ventilators shall be of the Gamma supply air type as designed and manufactured by Elta.

Impellers shall be backward-curved centrifugal design and driven by speed-controllable external rotor motors with integral thermal protection.

The cowls shall be manufactured from UV-stabilised plastic. Steel components to be corrosion protected. All models shall be fully tested as a complete assembled unit to BS848:Part 1, 1980 for airflow and BS848:Part 2, 1985 for noise.

Ancillary Equipment

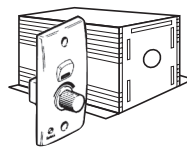

Speed controllers



VA - Speed controller

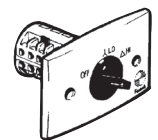

SD - Star/Delta switch

How To Order

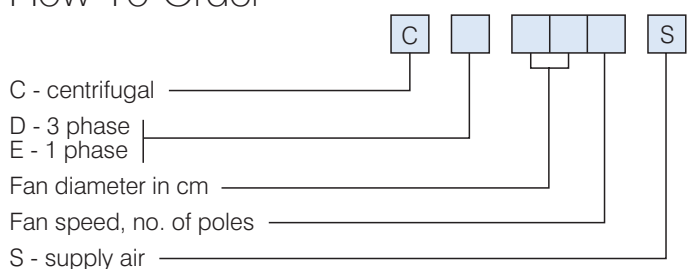

GAMMA SUPPLY

Technical Data

Model	Nom.		Avg. dB(A) @ 3m		CE.. 1 ph.		CD.. 3 ph.	
	Speed rev/	sec	Low Airflow	High Airflow	kW	Amps*	kW	Amps*
314.	23		49	50	0.15	0.66	0.18	0.37
316.**	15		45	42	0.07	0.54	0.09	0.15
354.	23		54	53	0.28	1.25	0.19	0.51
356.	15		47	45	0.07	0.32	0.13	0.22
404.	23		58	56	0.49	2.20	0.45	1.40
406.	15		49	48	0.17	0.80	0.23	0.73
408.	11		41	43	-	-	0.16	0.30
454.	23		61	59	0.76	3.50	0.77	1.47
456.	15		50	50	0.43	2.00	0.65	0.90
458.	11		44	46	-	-	0.15	0.35
504.	23		65	64	1.30	5.70	1.39	2.70
506.	15		52	52	0.53	2.50	0.65	1.20
508.	11		48	48	0.23	1.15	0.30	0.50
564.	23		69	69	-	-	2.16	4.10
566.	15		54	54	0.84	4.10	0.69	1.45
568.	11		49	50	0.32	1.50	0.39	0.79
634.	23		75	74	-	-	4.30	7.35
636.	15		61	58	-	-	1.10	2.20
638.	11		51	53	-	-	0.68	1.20
716.	15		63	60	-	-	2.20	4.30
718.	11		54	56	-	-	0.66	2.00
711.	9		48	50	-	-	0.28	1.20

Electrical data in **bold** type refers to fans that are fitted with 2-speed star/delta motors as standard.

* Amperages shown are a guide only, refer to our Sales Department for accurate figures at time of order.

** The CE316S is not speed controllable.

Noise Levels

Model	CD..S CE..S	Outlet	In-Duct Spectrum Corrections, dB*							
			63	125	250	500	1k	2k	4k	8k
314.	Outlet	31	25	19	19	14	12	7	0	
316.	Outlet	31	27	18	18	16	11	7	3	
354.	Outlet	24	27	16	17	16	14	8	1	
356.	Outlet	31	27	18	18	16	11	7	3	
404.	Outlet	26	26	17	17	16	13	10	6	
406.	Outlet	27	24	17	17	15	12	9	1	
408.	Outlet	30	23	16	15	16	15	11	1	
454.	Outlet	28	24	17	17	16	12	11	10	
456.	Outlet	24	22	17	16	15	13	11	0	
458.	Outlet	30	23	16	15	16	15	11	1	
504.	Outlet	26	24	17	16	16	10	9	8	
506.	Outlet	27	25	18	17	16	13	11	2	
508.	Outlet	32	24	17	16	16	14	11	1	
564.	Outlet	25	25	17	16	17	8	8	7	
566.	Outlet	30	27	19	17	16	12	10	3	
568.	Outlet	33	24	18	17	16	13	10	1	
634.	Outlet	24	27	18	16	18	7	7	7	
636.	Outlet	32	28	19	17	15	11	8	4	
638.	Outlet	34	24	18	17	16	11	9	0	
716.	Outlet	32	28	19	17	15	11	8	4	
718.	Outlet	34	24	18	17	16	11	9	0	
711.	Outlet	34	24	18	17	16	11	9	0	

* Add the In-Duct Spectrum Corrections to the closest dB(A) level shown on the fan curve to obtain the In-Duct Sound Power Levels on the Discharge Side of the Unit.

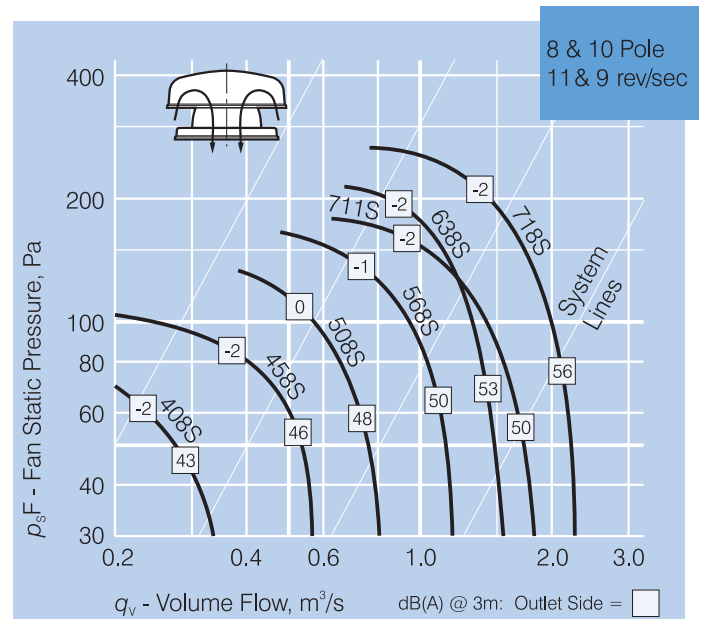
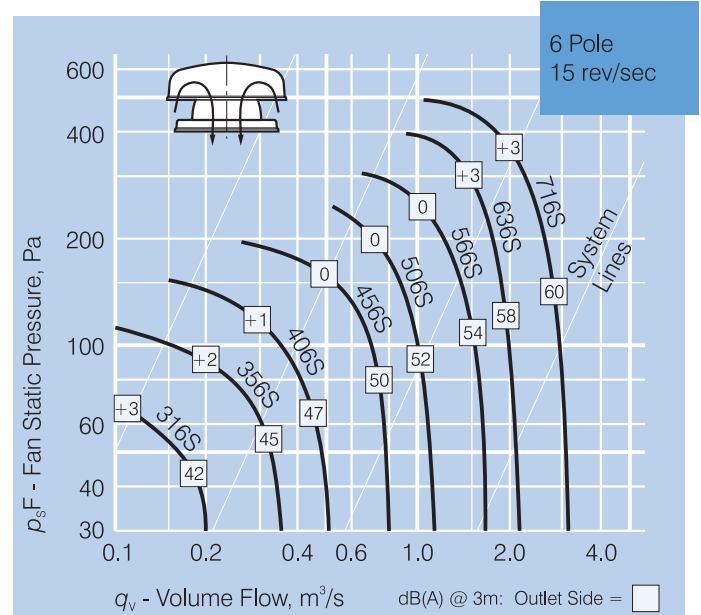
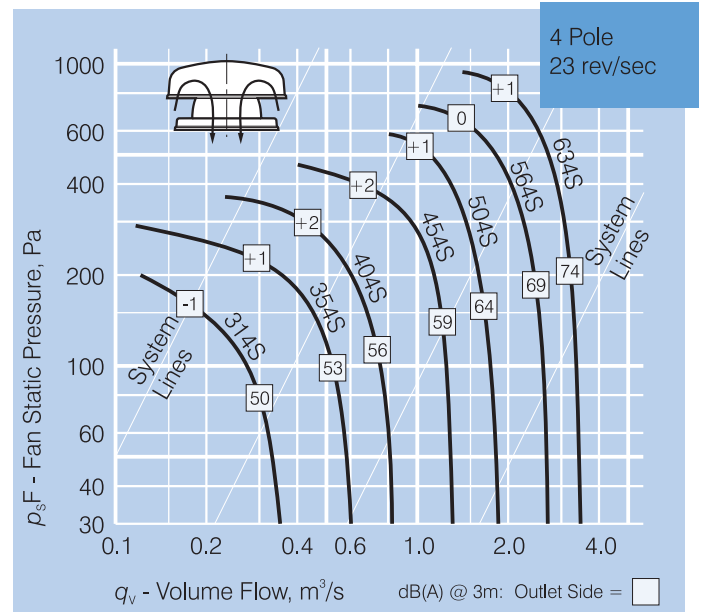



Elta Asia Sdn Bhd

Tel **+603 7846 0340**

Email **info@elta.asia**

elta.asia

GS-05-2026 Issue A



FS 676456

A MEMBER OF  ELTA GROUP