

GAMMA

Supply Air Roof Unit

ELTA





Description

The Gamma centrifugal roof units has been designed for use in commercial ducted exhaust applications. These compact and low profile units are fitted with birdmesh to prevent the entry of birds and vermin into the ducting or building. They are available in 12 sizes, extending from 192 to 710mm diameter.

Typical Applications

Exhaust air from a wide range of commercial applications such as factories, warehouses and workshops, change rooms, bulk goods retail outlets and assembly halls.

Features

- Robust, lightweight construction.
- Choice of speeds available.
- Compact, low profile design.
- Designed for down flow or vertical discharge applications.
- Twin vertical discharge fan also available. Provides 100% standby capacity.
- Shutters are standard on twin fan units and an optional extra for single fan units. The pressure loss across the shutter has to be added to the system pressure before making selections.
- Can be mounted at angle up to 30°.
- Most 3-phase motors are 2-speed star/delta design.
- Supply air units also available

Construction

Cowls are UV-stabilised plastic.

Impellers are backward-curved centrifugal design and can be plastic, steel or aluminium.

Steel components have a corrosion resistant finish.

Bird-mesh guards are fitted as standard to both downflow and vertical exhaust models.

Motor

Type - external rotor, squirrel cage induction motor.

Electricity supply - 230V, single and 415V, three-phase, 50Hz.

Ball Bearing - sealed for life.

Speed-controllable using electronic or auto-transformer controllers (except CE316).

Most three-phase units are fitted with 2-speed star/delta design motors.

Internal Thermal Protection

Thermal protection is supplied as standard on all motors.

Backdraft Damper Losses

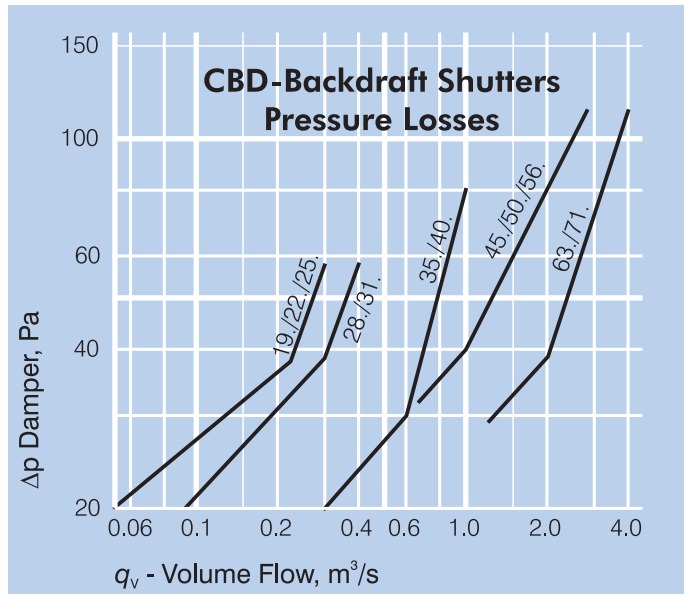

Testing

Airflow tests to ISO5801:2007

Noise tests to BS848:Part 2, 1985

How To Order

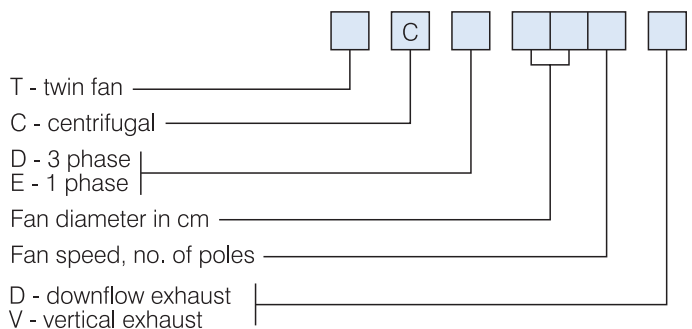

Technical Data

Model CD...D/V CE...D/V	Nom. Speed r/s	Avg dB(A) @ 3m		CE..1 ph.		CD..3 ph.		In-duct Spectrum Corrections, dB**							
		Low Air Flow	High Airflow	kW	Amps* Amps*	kW	Amps* Amps*	63	125	250	500	1k	2k	4k	8k
192.	42	Inlet 45	47	0.07	0.30	-	-	21	22	22	19	12	11	9	2
224.	23	Inlet 38	39	0.05	0.26	-	-	29	27	22	19	11	11	9	3
252.	42	Inlet 56	58	0.19	0.83	-	-	27	22	20	19	12	11	10	2
254.	23	Inlet 41	42	0.08	0.37	-	-	30	28	22	19	11	11	9	3
284.	23	Inlet 44	45	0.09	0.40	-	-	31	28	22	19	11	11	9	3
314.	23	Inlet 47	48	0.15	0.66	0.18	0.37	35	29	21	18	10	10	8	2
316.†	15	Inlet 40	42	0.07	0.54	0.09	0.15	34	26	22	18	12	12	6	0
354.	23	Inlet 52	51	0.28	1.25	0.19	0.51	28	26	22	19	10	12	11	1
356.	15	Inlet 43	43	0.07	0.32	0.13	0.22	33	25	22	19	14	8	3	0
404.	23	Inlet 56	54	0.49	2.20	0.45	1.40	28	26	21	18	11	12	12	5
406.	15	Inlet 44	44	0.17	0.80	0.23	0.73	33	28	22	19	14	10	7	3
408.	11	Inlet 39	40	-	-	0.16	0.30	33	26	19	16	14	14	12	3
454.	23	Inlet 59	57	0.76	3.50	0.77	1.47	27	25	20	17	11	12	12	8
456.	15	Inlet 47	46	0.43	2.00	0.44	0.90	31	30	21	18	13	11	9	5
458.	11	Inlet 41	43	-	-	0.15	0.35	33	26	19	16	14	14	12	3
504.	23	Inlet 62	61	1.30	5.70	1.39	2.70	26	26	21	15	12	12	12	9
506.	15	Inlet 50	50	0.53	2.50	0.65	1.20	30	29	22	16	12	10	8	6
508.	11	Inlet 43	45	0.23	1.15	0.30	0.50	32	26	20	16	14	13	12	4
564.	23	Inlet 65	65	-	-	2.16	4.10	26	27	23	14	13	12	12	10
566.	15	Inlet 54	54	0.84	4.10	0.69	1.45	29	29	23	15	12	10	8	7
568.	11	Inlet 44	47	0.32	1.50	0.39	0.79	30	27	22	15	15	11	11	6
634.	23	Inlet 69	70	-	-	4.30	7.35	24	28	24	12	13	11	12	10
636.	15	Inlet 60	58	-	-	1.10	2.20	28	29	24	14	12	10	8	8
638.	11	Inlet 46	50	-	-	0.68	1.20	28	27	23	14	14	9	10	6
716.	15	Inlet 63	61	-	-	2.20	4.30	28	29	24	14	12	10	8	8
718.	11	Inlet 48	53	-	-	0.66	2.00	28	27	23	14	14	9	10	6
711.	9	Inlet 41	46	-	-	0.28	1.20	28	27	23	14	14	9	10	6

Electrical data in **bold** type refers to fans fitted with 2-speed star/delta motors as standard.

* Amperages shown are a guide only, refer to our Sales Department for accurate figures at time of order.

** Add the In-Duct Spectrum Corrections to the closest dB(A) level shown on the fan curve to obtain the In-Duct Sound Power Levels on the Inlet Side of the unit.

† The CE316. model is not speed-controllable.

Dimensions

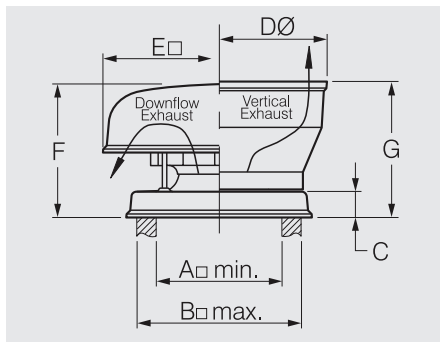

Single Fan Units

Model No. CD... CE...	Dimensions, mm							Approx. weight kg.	Approx. volume m ³
	A	B	C	DØ	E	F	G		
192-254	260	310	50	430	370	200	244	4	0.05
284-316	310	410	75	500	575	330	334	8	0.13
354-408	400	500	75	640	670	410	417	18	0.22
454-568	620	720	75	908	890	530	540	38	0.52
634-711	710	810	75	1260	1180	650	695	69	1.28

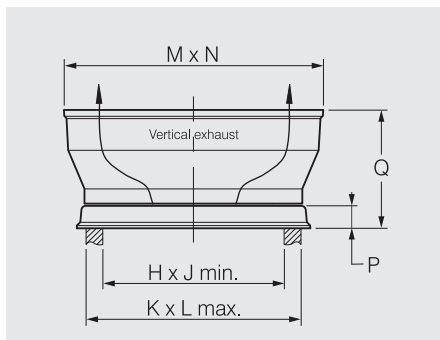

Twin Fan Units

Model No. TCD... TCE...	Dimensions, mm								Approx. weight kg.	Approx. volume m ³
	H	J	K	L	M	N	P	Q		
252-254	600	260	650	310	770	430	50	244	8	0.10
314-316	700	310	800	410	892	500	75	334	16	0.18
354-408	900	400	1000	500	1196	640	75	417	36	0.37
454-568	1330	620	1430	720	1630	908	75	540	76	0.92

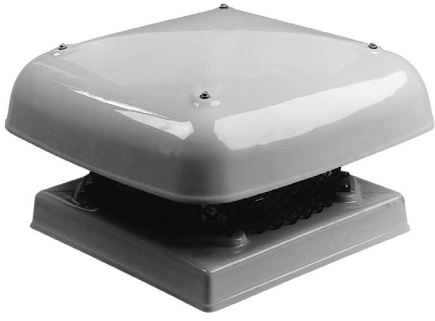

Suggested Specification

Downflow Exhaust

The Gamma centrifugal roof ventilators shall be the downflow exhaust type as designed and manufactured by Elta.

Impellers shall be backward-curved centrifugal design and driven by speed-controllable external rotor motors with integral thermal protection.

The cowl shall be of the downflow exhaust design and formed from plastic and/or fibreglass. Steel components are corrosion protected.

All models shall be fully tested as a complete assembled unit to ISO5801:2007 for airflow and BS848:Part 2, 1985 for noise.

Ancillary Equipment

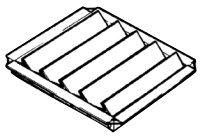

CBD - Backdraft shutter

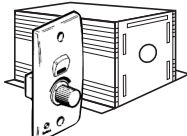

Speed controllers

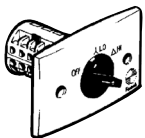

SD - Star/Delta switch

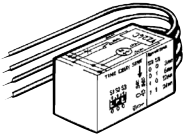

VZ - Run-on timer

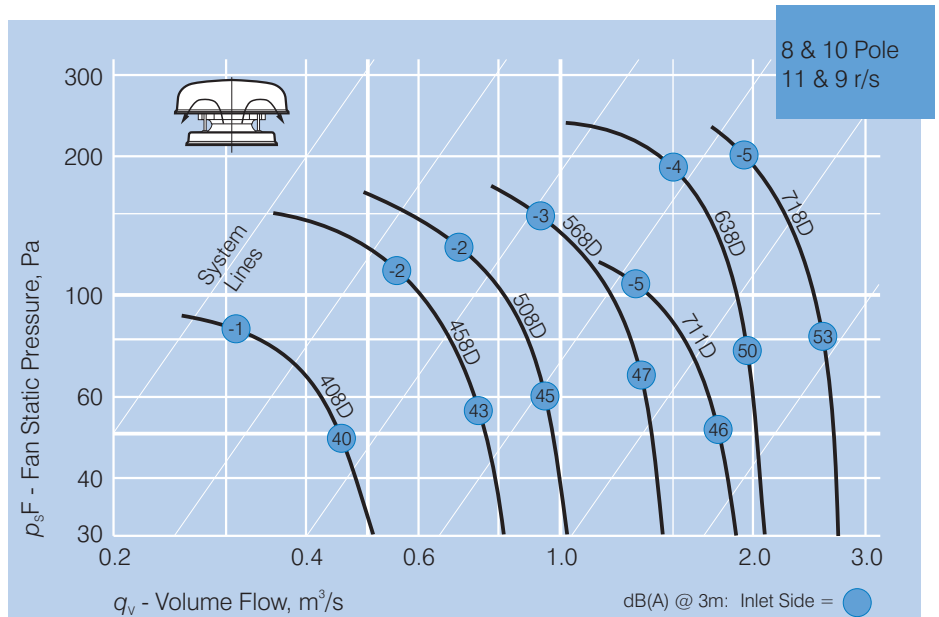
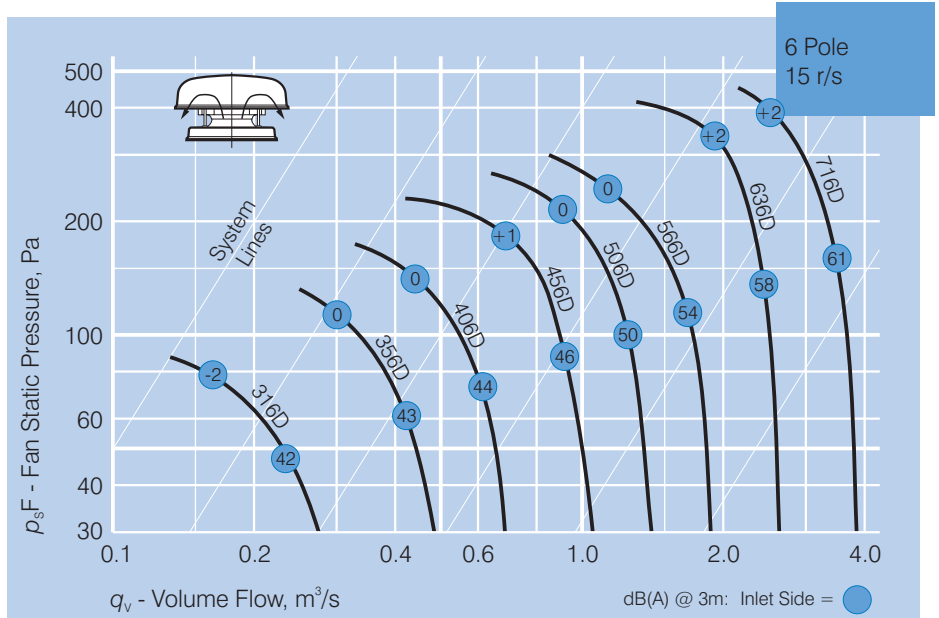
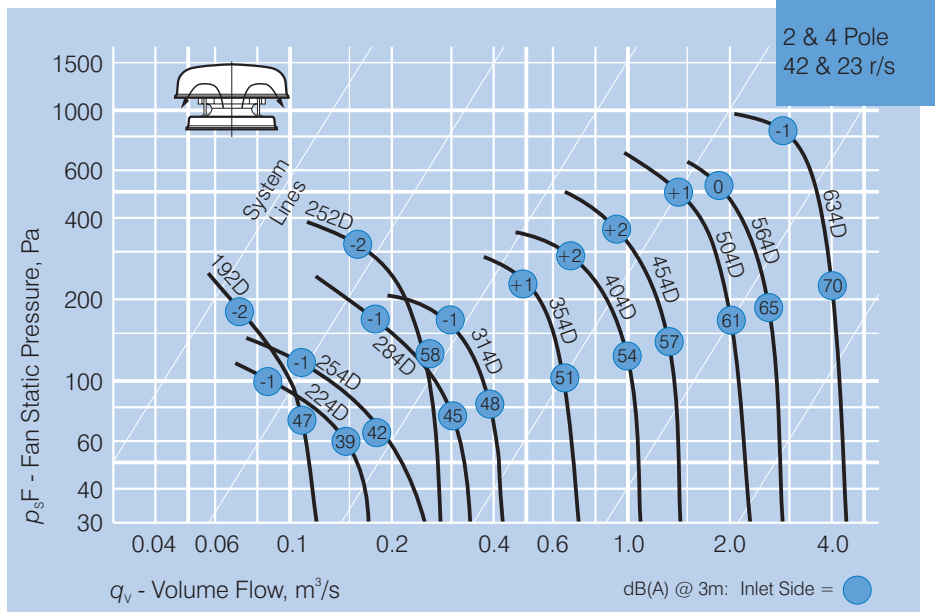



Suggested Specification

Vertical Exhaust

The Gamma centrifugal roof ventilators shall be of the vertical exhaust type as designed and manufactured by Elta.

Impellers shall be backward-curved centrifugal design and driven by speed-controllable external rotor motors with integral thermal protection.

The windband shall be of the vertical exhaust design and formed from plastic. Steel components shall be corrosion protected.

All models shall be fully tested as a complete assembled unit to ISO5801:2007 for airflow and BS448:Part 2, 1985 for noise.

Ancillary Equipment

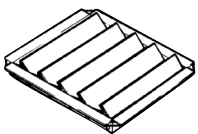

CBD - Backdraft shutter

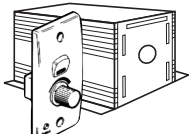

Speed controllers

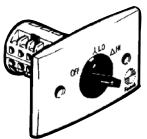

SD - Star/Delta switch

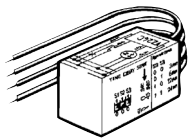

VZ - Run-on timer

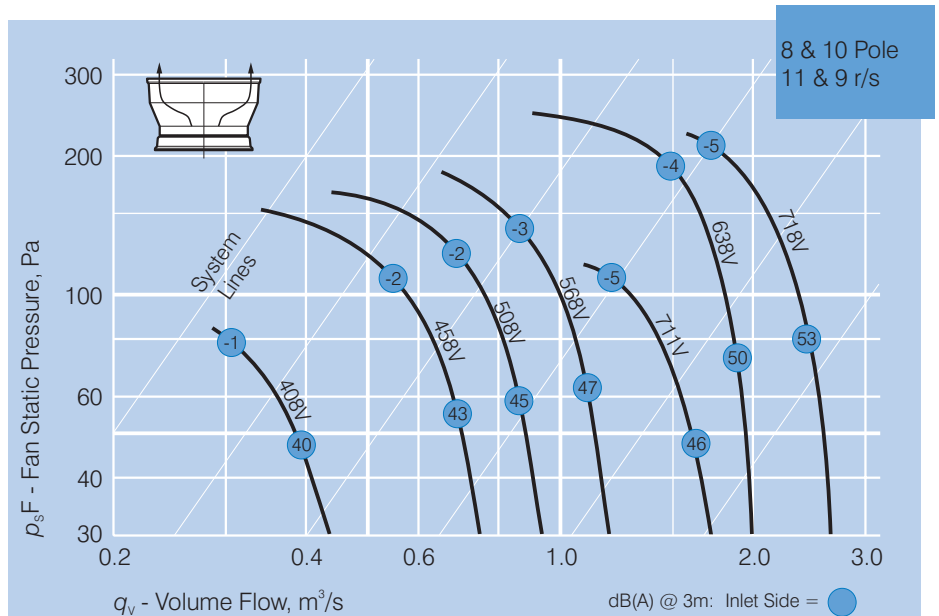
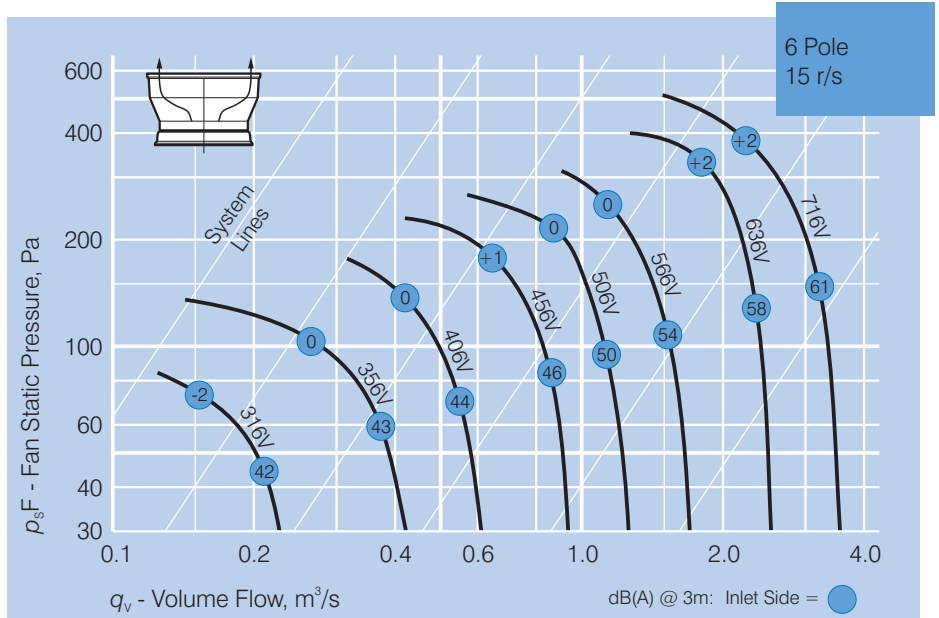
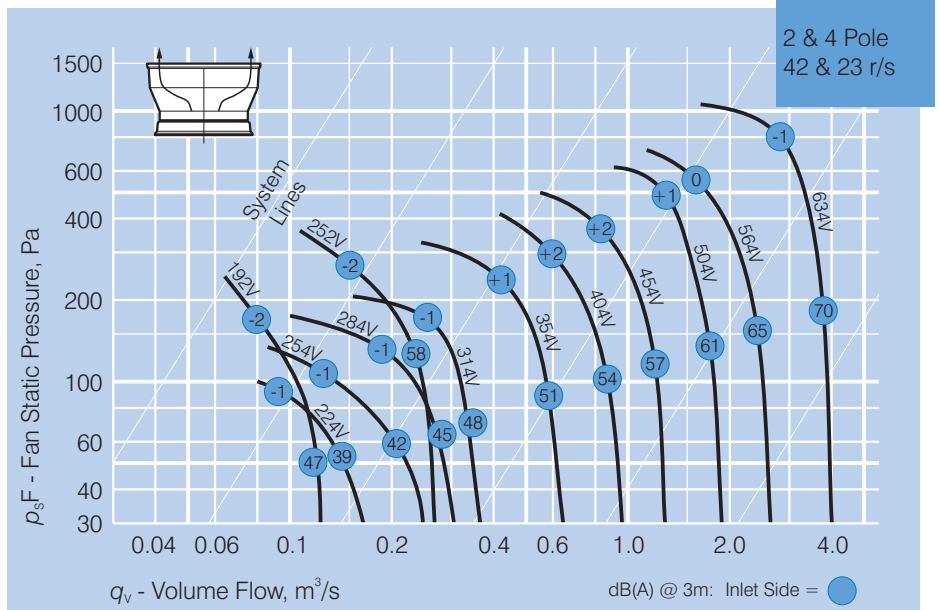



Elta Asia Sdn Bhd

Tel **+603 7846 0340**

Email **info@elta.asia**

elta.asia

GS-05-2026 Issue A



FS 676456

A MEMBER OF  ELTA GROUP