

HIT

Duct Mounted In-line Centrifugal Fan

ELTA





Ancillary Equipment

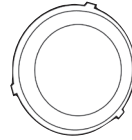

Ceiling Grilles

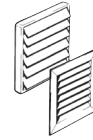

Ducting, Louvres & Grilles

Description

The HIT Series of duct-mounted centrifugal in-line fans is designed to exhaust or supply air to a wide range of applications. This powerful in-line fan is perfect for direct duct connection. All metal galvanised body means the fan will last under hard wearing applications. Backward curved impellers create a strong reliable airflow and a stall free performance. Available in 7 models to suit 100 to 315mm spigot sizes.

Typical Applications

Suitable for ventilating in residential, commercial and industrial applications such as wine cellars, toilets, kitchens and bathrooms in homes, hotels, apartments and offices. Also suitable for equipment cooling.

Features

- Available in 7 models to suit 100 to 315mm diameter spigot sizes.
- Housing is manufactured from DX56 galvanised steel, rotor has an aluminium casing.
- Backward curved impellers create a strong reliable airflow and a stall free performance.
- Ball bearing motor for long lifespan.
- External rotor AC motor.
- Motors and impellers are balanced to G6.3.
- Built in non self-resetting thermal cut off.
- Rated IP44.
- Class F insulation.

Construction

The housing is manufactured from DX56 galvanised steel, rotor has an aluminium casing that is made to last. Impellers are backward-curved centrifugal driven by external rotor motors.

Motor

Type - external rotor motors.

Electrical supply - 230V, single-phase, 50/60Hz.

Ball Bearing - sealed for life.

Maximum ambient temperature - 50°C.

Class F insulation, IP44.

Testing

Contact your local office for further information.

Internal Thermal Protection

Non self-reset thermal protector.

Suggested Specification

In-line fans of the HIT Series shall be as supplied by Elta. Impellers shall be backward-curved centrifugal design and driven by speed-controllable external rotor motors with integral thermal overload protection. The housing is of DX56 galvanised steel.

How To Order

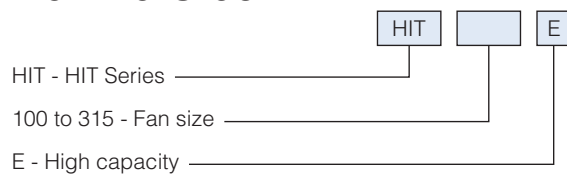

Technical Data

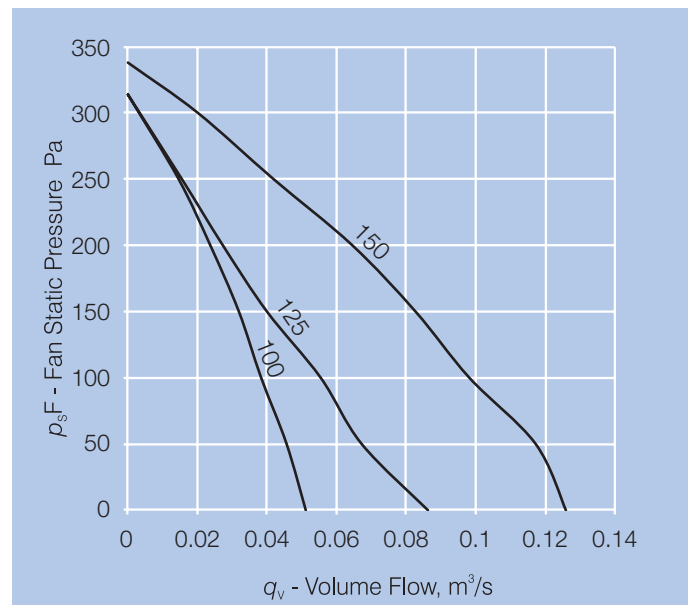

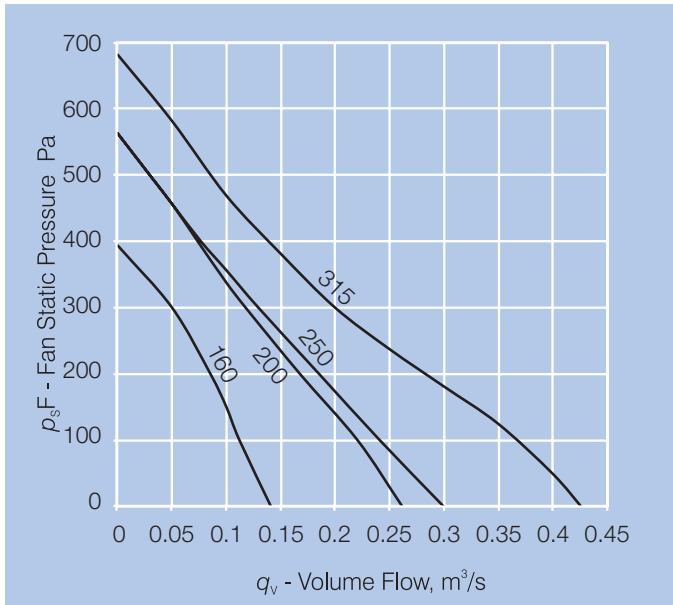

Model HIT...	Free Air m³/sec	Fan Speed rev/sec	Avg dB(A) @3m	Watts	Amps	Approx. weight kg.
100E	0.051	43	47	65	0.30	3.7
125E	0.087	42.5	47	70	0.30	3.7
150E	0.127	43	50	70	0.30	3.6
160E	0.14	44	50	125	0.60	3.6
200E	0.261	41	52	170	0.70	5.5
250E	0.30	41	54	170	0.70	5.3
315E	0.427	41	57	250	1.20	8.1

Dimensions

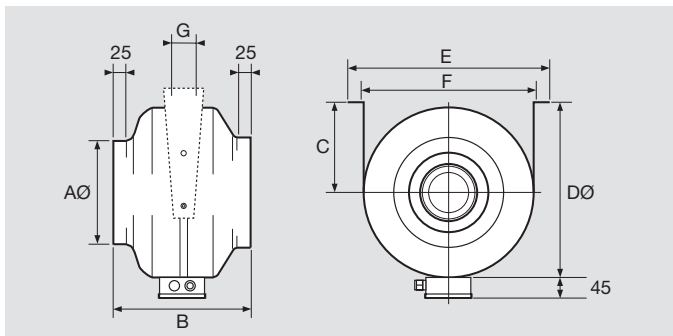

Model Number HIT...	Dimensions, mm						
	AØ	B	C	DØ	E	F	G
100E	98	204	130	236	284	270	47
125E	123	193	130	236	284	270	47
150E	148	195	165	278	326	312	47
160E	158	195	165	278	326	312	47
200E	198	235	190	333	392	372	100
250E	248	210	190	333	392	372	100
315E	313	265	227	400	460	440	100



Elta Asia Sdn Bhd

Tel **+603 7846 0340**

Email **info@elta.asia**

elta.asia

HIT-01-2026 Issue A



FS 676456

A MEMBER OF  ELTA GROUP