

NEW GENERATION BFC

ELTA

Bushfire Compliant Heavy Duty Axial Roof Unit

BUSHFIRE CODE COMPLIANT



NEW GENERATION BFC



Available in supply air only



Description

The heavy duty New Generation with bushfire code compliance, has been developed for use in free intake or ducted installations. These supply air axial roof units feature a low profile and comply with BAL-LOW to BAL-40 of the Australian Standard AS3959:2009 Construction buildings in bush fire prone areas.

There are 6 sizes in the range extending from 315 to 710mm diameter.

Typical Applications

Ideal for supplying fresh air to an air handling unit or to an air conditioning system. Also suitable where make-up air or positive pressure is required in the ventilated space.

Features

- Robust, heavy duty galvanised steel construction.
- High quality bronze mesh provides protection from burning embers.
- Adjustable pitch impellers provide performances to suit a wide range of applications
- 2-speed motors can be supplied.
- Can be used for ducted applications.
- Wide choice of speeds available.
- Can be speed controlled using variable speed drives.
- Can be mounted at angles up to 30°.
- Compliant to AS3959:2009 up to and including BAL-40.

Construction

Cowls are of galvanised steel.

Bronze mesh with a maximum of 2mm aperture fitted. Impeller blades can be GRP, aluminium, nylon or anti-static to suit the application. GRP is standard.

Motor

Type - squirrel cage induction motor.

Electricity supply - motors to suit a wide range of voltages and frequencies can be supplied.

Ball Bearing - sealed for life.

Speed-controllable using variable speed drives.

Motors with 2-speed windings, or to meet Ex d, Ex e, Ex nA and Ex tD Standards, can be supplied.

When fans are required for non-standard air applications this must be nominated at the time of enquiry.

Internal Thermal Protection

Thermistors can be provided on all motors except when Standards specifically exclude their use.

Testing

Airflow tests to BS848:Part 1, 1980

Noise tests to BS848:Part 2, 1985

Additional Information

Construction of buildings in bushfire prone areas

AS3959:2009, clause 6.6.5(b) "Roof penetrations" states:

Openings in vented roof lights, roof ventilators or vent pipes shall be fitted with ember guards made from a mesh or perforated sheet with a maximum aperture of 2mm, made of corrosion-resistant steel, bronze or aluminium.

Selection

The quick select envelope performance curves shown on pages D-18/19 give a guide to fan size, noise level and speed. Accurate selections, including comprehensive noise data, can be obtained from your local Elta office or from the Intelligent Ventilation Product Selection Program. Refer to Elta for performances at speeds other than shown.

Ancillary Equipment



Variable speed drives

How To Order

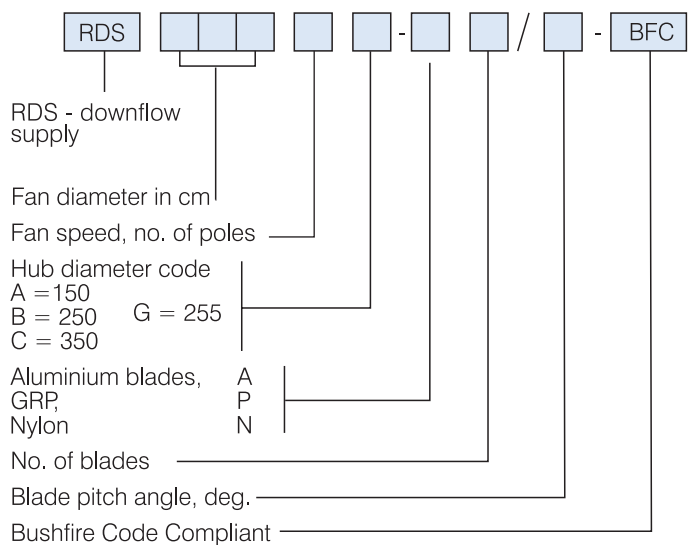

NEW GENERATION BFC

Dimensions

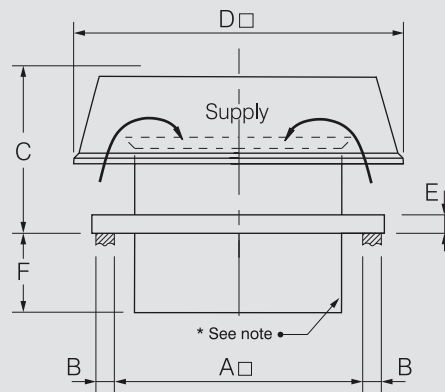

Model RDS...-BFC	Fan Speed rev/sec	Max. Motor kW	Dimensions, mm						App. vol. RD.. m ³
			A□	B	C	D□	E	F	
0314	24	0.37	400	50	380	670	80	285	0.34
0316	16	0.37							
0404	24	0.55	510	50	430	770	80	245	0.45
0406	16	0.37							
0504	24	1.50	670	50	530	890	80	365	0.83
0506	16	0.37							
0564	24	2.2	670	50	530	890	80	365	0.83
0566	16	0.75							
0634	24	4.0	780	100	580	1180	80	345	1.60
0636	16	1.1							
0638	12	0.55	780	100	580	1180	80	345	1.60
0714	24	5.5							
0716	16	2.20	780	100	580	1180	80	345	1.60
0718	12	0.75							

* If right angle flanged connection is required this is available as an optional extra.
Amperages for motors can be obtained at time of order.

Suggested Specification

The axial roof units shall be of the New Generation with bushfire code compliance as designed and manufactured by Elta. The cowl shall be of the downflow type and manufactured from galvanised steel.

The axial impellers shall be adjustable pitch manufactured and supplied with blades of GRP, aluminium, nylon or anti-static material to suit the application.

The unit base shall be of galvanised steel and shall incorporate a tube that fully encompasses the motor and impeller. In addition, the intake end of the casing shall have an inlet cone to minimise entry losses to the fan.

Ember protection mesh shall be of bronze or steel with openings a maximum of 2mm.

All data is based on tests to BS848:Part 1, 1980 for airflow and BS848:Part 2, 1985 for noise.



Elta Asia Sdn Bhd

Tel **+603 7846 0340**

Email **info@elta.asia**

elta.asia

NGBFC-05-2026 Issue A



FS 676456

A MEMBER OF  ELTA GROUP