

# NEW GENERATION

Heavy Duty Axial Roof Unit

---

**ELTA**



# NEW GENERATION



## Description

The heavy duty New Generation axial roof units has been designed for a wide range of free intake and ducted applications. These exhaust fans are suitable for a wide range of commercial and industrial applications for handling clean air through to smoke-spill.

There are 9 sizes extending from 315 to 1250mm diameter.

### Typical Applications

Can exhaust from a range of commercial and industrial applications such as warehouses and factories with air qualities ranging from clean air to toxic, noxious and corrosive gases and smoke-spill.

### Features

- Robust, heavy duty construction.
- New Generation downflow supply air units can also be supplied.
- Adjustable pitch impellers provide performances to suit a wide range of applications.
- Impellers can be GRP, aluminium, nylon or anti-static to suit the application, GRP is standard.
- Shutters are a standard component for the RVE and RSS models and are an optional extra for the RDE units (see Additional Information).
- Can be mounted at angles up to 30°.
- All standard motors are speed-controllable using variable speed drives.
- Can be used for free intake and ducted applications.
- Wide choice of speeds available.
- Multi-speed motors, as well as motors to meet Ex d, Ex e, Ex nA and Ex tD Standards can be supplied.
- For installations prone to high prevailing winds refer to Additional Information.

### Construction

Galvanised steel bases; cowls/wind bands are of plastic, fibreglass or galvanised steel.

The RVE and RSS models are all steel construction.

Impeller blades can be GRP, aluminium, nylon or anti-static to suit the application. GRP is standard.

### Motor

Type - squirrel cage induction motors.

Electricity supply - motors to suit a wide range of voltages and frequencies can be supplied.

Ball Bearing - sealed for life.

Speed-controllable using variable speed drives.

See pages O-3/4 for details on these motors.

Motors with 2-speed windings, or to meet Ex d, Ex e, Ex nA and Ex tD Standards, can be supplied.

When fans are required for non-standard air applications this must be nominated at the time of enquiry.

### Internal Thermal Protection

Thermistors can be provided on all motors except when Standards specifically exclude their use.

### Testing

Airflow tests to BS848:Part 1, 1980

Noise tests to BS848:Part 2, 1985

### Discharge Damper Fail-open Latching

An additional requirement of AS/NZS1668.1:1998 with respect to un-sprinklered buildings (300°C for 30mins) requires dampers to fail-open during smoke spill operation.

The fail-open discharge damper latches come in two forms; the first being a manual release type requiring manual closing after the fan has been run. The second design, an electro-mechanical type permits the shutter latch to release and close automatically after the fan stops.

For advice on smoke-spill wiring requirements refer to AS/NZS1668.1:1998.

### Additional Information

The quick select envelope performance curves shown on pages D-18/19 give a guide to fan size, noise level and speed. Accurate selections, including comprehensive Noise Data, can be obtained from your local Elta office or from the Intelligent Ventilation Product Selection Program. Refer to Elta for performances at speeds other than shown.

When shutters are fitted ensure the roof unit is mounted with the shutter spindle pointing down the roof. When shutters are fitted to the RDE models derate the performance by 15-20%. Where prevailing winds are high we recommend the fitting of Magloks®. For capacities greater than shown for the New Generation units refer to the HC and SS units.

### Smoke-Spill Application

The New Generation RSS smoke-spill fans has been fully tested to meet the air performance and high temperature requirements of Standards AS/NZS1668.1:1998 and AS4429:1999.

## How To Order

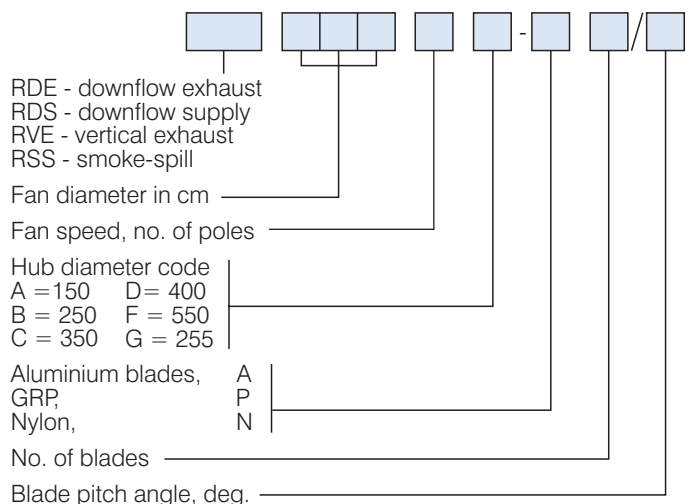

# NEW GENERATION

## Dimensions

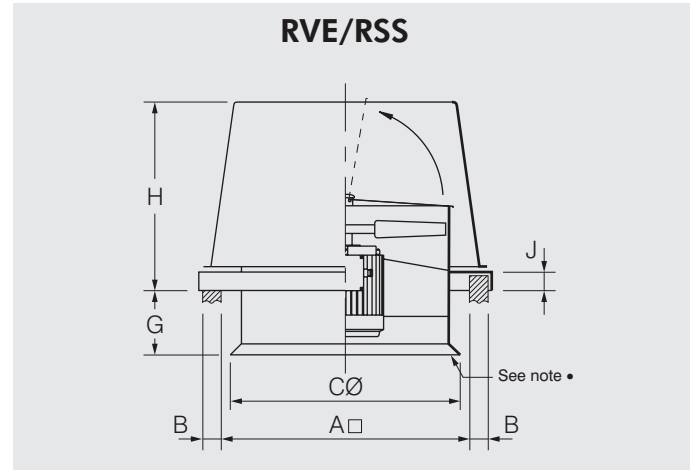
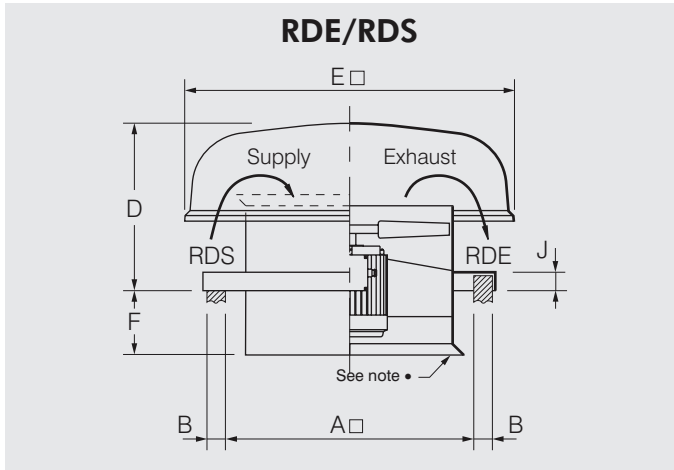

Model RDE/S... RVE/SS.	Fan Speed rev/sec	Max. Motor kW	Dimensions, mm										App. vol. RD.. m <sup>3</sup>	App. vol. RV.. m <sup>3</sup>
			A□	B	CØ	D	E□	F max.	G max.	H	J			
<b>0314</b>	24	0.37	400	50	380	380	670	285	285	385	80	0.34	0.24	
<b>0316</b>	16	0.37												
<b>0404</b>	24	0.55	510	50	465	430	770	245	245	445	80	0.45	0.36	
<b>0406</b>	16	0.37												
<b>0504</b>	24	1.50	670	50	570	530	890	365	365	545	80	0.83	0.72	
<b>0506</b>	16	0.37												
<b>0564</b>	24	2.2	670	50	625	530	890	365	365	545	80	0.83	0.72	
<b>0566</b>	16	0.75												
<b>0634</b>	24	4.0	780	100	700	580	1180	345	345	685	80	1.60	1.30	
<b>0636</b>	16	1.1												
<b>0638</b>	12	0.55	780	100	776	580	1180	345	545	685	80	1.60	1.40	
<b>0714</b>	24	5.5												
<b>0716</b>	16	2.20	780	100	776	580	1180	345	545	685	80	1.60	1.40	
<b>0718</b>	12	0.75												
<b>0804</b>	24	11.0	880	100	870	685	1395	530	530	765	85	3.10	1.80	
<b>0806</b>	16	4.0												
<b>0808</b>	12	1.5	880	100	870	685	1395	530	530	765	85	3.10	1.80	
<b>1004#</b>	24	30.0												
<b>1006</b>	16	15	1080	100	1070	725	1640	495	495	855	85	3.80	2.60	
<b>1008</b>	12	4.0												
<b>1254#</b>	24	90	1370	100	1330	-	-	-	810	840	85	-	4.30	
<b>1256#</b>	16	30												
<b>1258#</b>	12	11.0	1370	100	1330	-	-	-	810	840	85	-	4.30	

• All casings have coned entry. If right angle flanged entry is required this is available as an optional extra.

# Vertical discharge RVE/RSS only.

Amperages for motors can be obtained at time of order.

# NEW GENERATION



## Ancillary Equipment

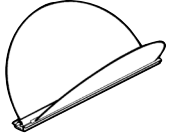

ABD - Butterfly shutters



Variable speed drives

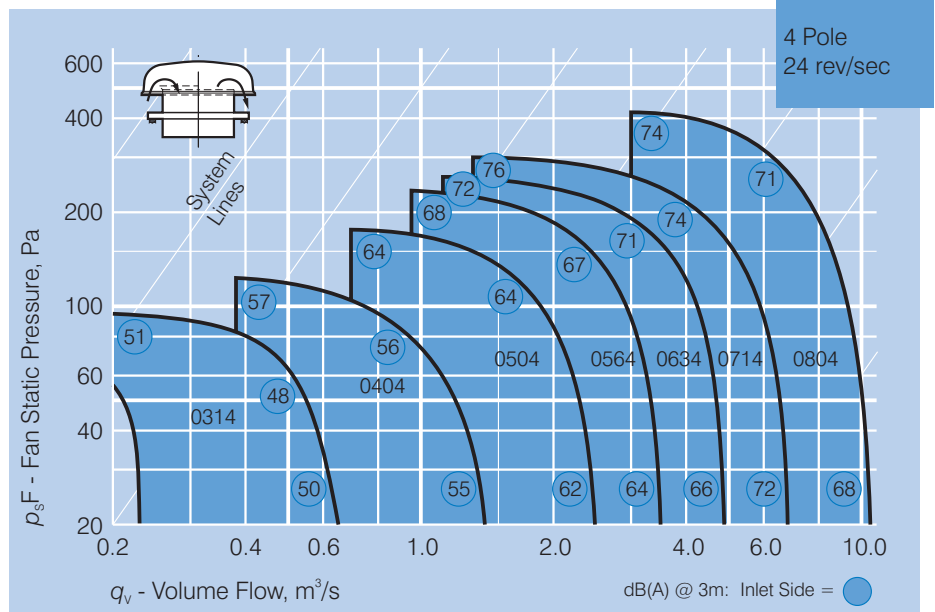

## Suggested Specification

### Downflow Exhaust

The axial roof units shall be of the RDE downflow exhaust New Generation as designed and manufactured by Elta.

The axial impellers shall be adjustable pitch manufactured and supplied with blades of GRP, aluminium, nylon or anti-static material; GRP is standard.

The unit base shall be of galvanised steel and incorporate a tube that fully encompasses the motor and rotor. In addition, the intake end of the casing shall have an inlet cone to minimise entry losses to the fan.

The base may be powder-coated if required (optional extra). Cowls shall be of plastic or fibreglass.

All models shall incorporate fans fully tested to BS848:Part 1, 1980 for airflow and to BS848:Part 2, 1985 for noise.

### Downflow Supply

The axial roof units shall be of the RDS downflow supply New Generation as designed and manufactured by Elta.

The axial impellers shall be adjustable pitch manufactured and supplied with blades of GRP, aluminium, nylon or anti-static material; GRP is standard.

The unit base shall be of galvanised steel and incorporate a tube that fully encompasses the motor and rotor.

In addition, the intake end of the casing shall have an inlet cone to minimise entry losses to the fan. The base may be powder-coated if required (optional extra). Cowls shall be of plastic or fibreglass.

All models shall incorporate fans fully tested to BS848:Part 1, 1980 for airflow and to BS848:Part 2, 1985 for noise.

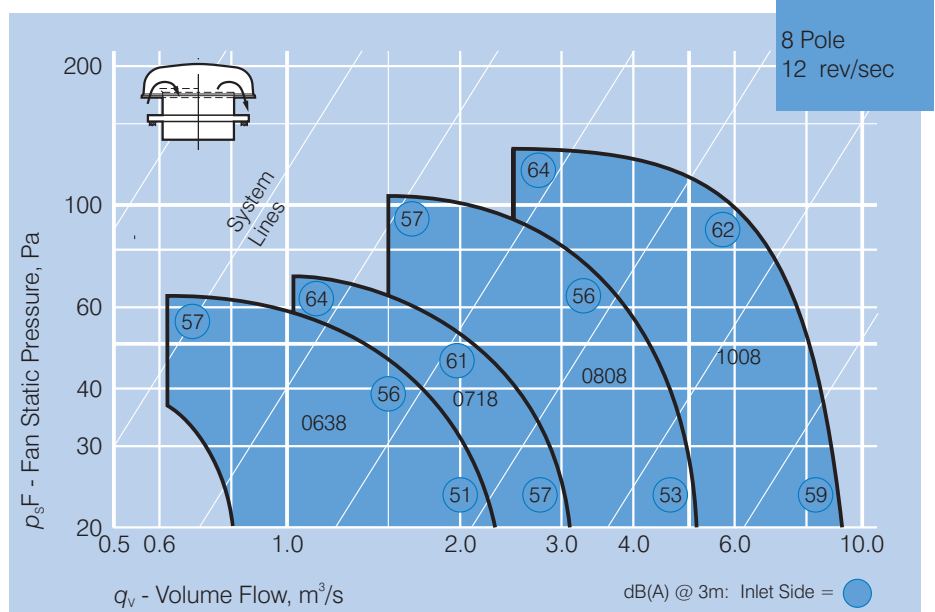
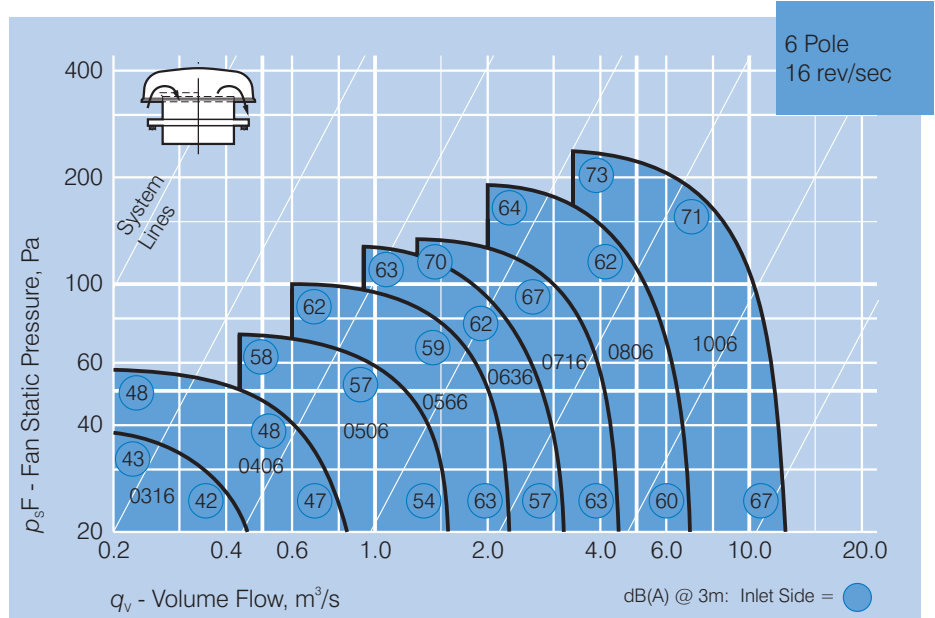

# NEW GENERATION

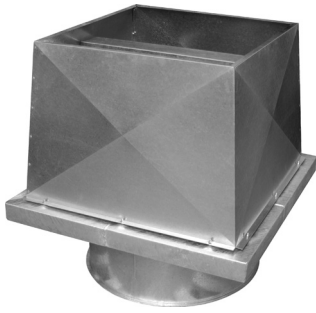

## Ancillary Equipment

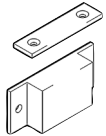

Maglok®



Variable speed drives

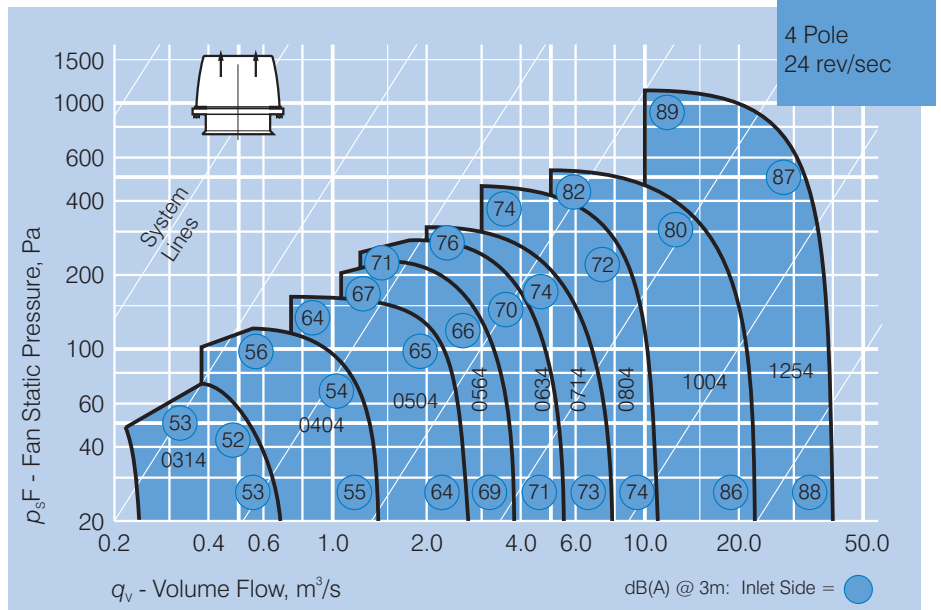

## Suggested Specification

### Vertical Exhaust

The axial roof ventilators shall be of the RVE vertical exhaust New Generation units as designed and manufactured by Elta.

The axial impellers shall be adjustable pitch manufactured and supplied with blades of GRP, aluminium, nylon or anti-static material; GRP is standard.

The unit base shall be of galvanised steel and shall incorporate a tube that fully encompasses the motor and rotor. In addition, the intake end of the casing shall have an inlet cone to minimise entry losses to the fan. The base and steel windband may be powder-coated if required (optional extra). Windbands shall be of galvanised steel.

All models shall incorporate fans fully tested to BS848:Part 1, 1980 for airflow and to BS848:Part 2, 1985 for noise.

### Vertical Exhaust Smoke-Spill

The axial roof ventilators shall be of the RSS vertical exhaust smoke-spill, New Generation as designed and manufactured by Elta.

The axial impellers shall be adjustable pitch manufactured and supplied with blades of GRP, aluminium, nylon or anti-static material; GRP is standard.

The unit base shall be of galvanised steel and shall incorporate a tube that fully encompasses the motor and rotor. In addition, the intake end of the casing shall have an inlet cone to minimise entry losses to the fan. The base and steel windband may be powder-coated if required (optional extra). Windbands shall be of galvanised steel.

All models shall incorporate fans fully tested to BS848:Part 1, 1980 for airflow and to BS848:Part 2, 1985 for noise.

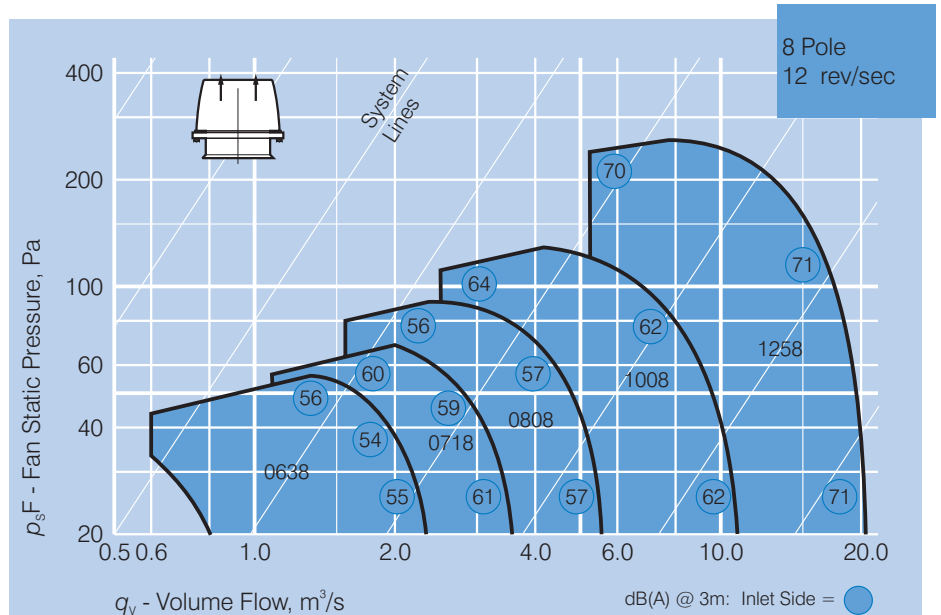
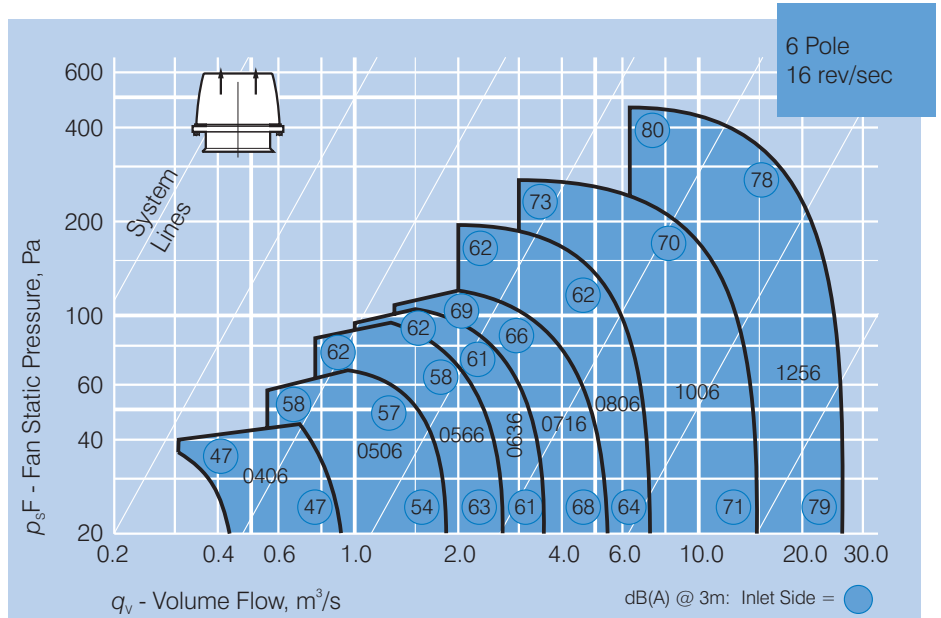







Elta Asia Sdn Bhd

Tel **+603 7846 0340**

Email **info@elta.asia**

**elta.asia**

NG-05-2026 Issue A



FS 676456

A MEMBER OF  ELTA GROUP