

QUASAR

Mixed Axial Fan

ELTA





Description

The Quasar fan is modern ventilation on a whole new level, featuring Apex Air Science. Ultra quiet extract fan designed and developed in Italy by Elta Group fan engineers in one of Europe's most sophisticated Air Science Labs. Over two years of product development and countless prototypes has spawned a new breed in domestic fan performance. Suitable to extract air directly outside or through short length ducting. This fan can be wall and ceiling mounted. Available in 100mm model only.

Typical Applications

Exhaust from toilets, ensuites bathrooms, washrooms, laundries and other small to medium spaces.

Features

- Stylish front grille for a modern clean look.
- IP45 Rated.
- Low power consumption 5W (Quasar 2SBB).
- Powerful airflow 105 m³/h.
- High quality ball bearing motor for fan life of more than 30,000 hours.
- Quiet running at 22dB(A) (Quasar 2SBB).
- Highly efficient impeller providing enhanced aerodynamic properties, low noise levels and increased efficiency.
- Angled guide vanes to improve efficiency and reduce noise.
- Built in spigot support to prevent distortion with strengthened guard to maximise airflow.
- High quality long lasting casing absorbs impact and vibrations to reduce noise.
- European made motor up to 50% more efficient than a traditional AC domestic fan.
- Includes backdraft shutter that prevents outside air entering building when fan is switched off.
- Double insulated so no earth connection is required.
- Single phase induction motors with integral thermal protection.
- Suitable for continuous and intermittent running.
- Comes with 5 year warranty.

Construction

Fan housing made from high quality technopolymer which is shock proof and long lasting.

Finished in white RAL 9010 and UV resistant.

Model includes backdraft shutter.

Motor

Type - single phase induction motor.

Electricity supply - single phase 220-240V, 50/60Hz.

Bearings - ball.

Maximum ambient temperature - 50°C.

Class II insulation, IP45 rated.

Internal Thermal Protection

Model 2SBB and N BB - fuse.

Testing

Airflow to ISO 5801:2007

Noise to ISO 3741:2010

Ancillary Equipment



Duct



External Grilles

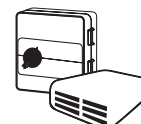

Controllers

Suggested Specification

The wall/ceiling fan shall be of the Quasar Series as supplied by Elta and be of the model shown.

It shall have a single phase induction motor with ball bearings, and built in thermal protection.

All models shall be fully tested to ISO 5801:2007 for airflow and ISO 3741:2010 for noise.

Technical Data

Model Number	Free Air m ³ /sec	Avg. dB(A) @ 3m	Watts	Max. °C
QUASAR... 2SBB	0.029/0.019	26/22	8/5	50
N BB	0.026	25	8	50

How To Order



Dimensions

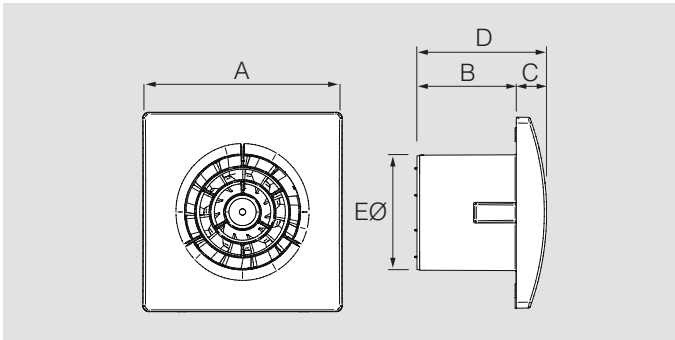

Model QUASAR...	Dimensions, mm					Approx. wt. kg
	A	B	C	D	EØ	
2SBB	164	84	27	111	99.4	0.5
N BB						

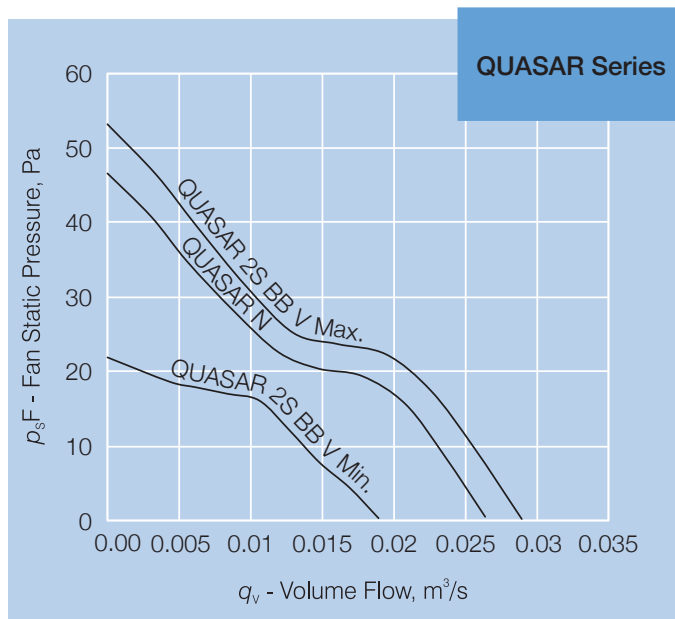



Elta Asia Sdn Bhd

Tel **+603 7846 0340**

Email **info@elta.asia**

elta.asia

QUASAR-05-2026 Issue A



FS 676456

A MEMBER OF  ELTA GROUP