

NOISE CONTROL PRODUCTS

Accessories

ELTA



ATTENUATOR SELECTION PROCEDURE

Introduction

Assessing whether an attenuator would reduce noise effectively enough for a particular situation usually requires complete equipment noise data and attenuator insertion loss (SIL) spectrums. Acoustic calculations then have to be performed to assess the resultant noise levels with the attenuator.

To give the reader a general understanding of the noise reduction performance of different attenuators, the methodology presented in this section provides attenuator performance as a single noise reduction value against a Low Frequency Biased or General HVAC noise profile.

The performance of an attenuator in a specific case may vary from these general noise reductions. To assess if this general advice applies to a specific case, assistance is available through our nearest sales office and through the acoustic analysis tool in the Intelligent Ventilation Selection Program and Elta Website.

To make an attenuator selection that will provide satisfactory performance, there are several criteria that have to be addressed.

1. Acoustic attenuation/silencing performance

The reduction in noise offered by an acoustic attenuator varies according to the source of the noise being controlled. Being technically specific, it depends on whether the noise is particularly loud in low frequencies/tones. In the example below, two different noises could have the same overall decibel levels but because one is from a generator set (low frequency biased), the performance of the same acoustic attenuator varies to that of a general HVAC system.

General fan noise (Example fan coil unit)

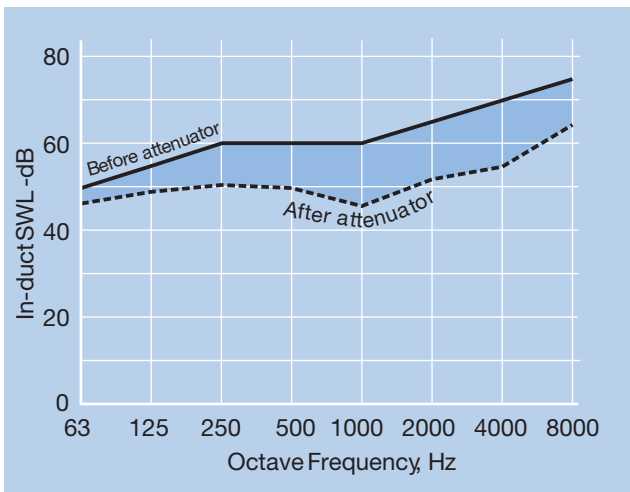
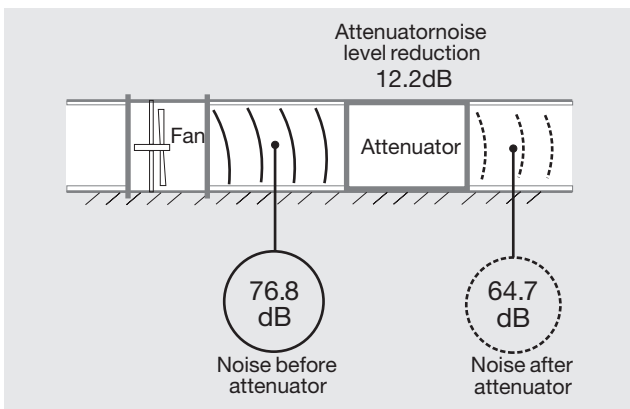

	High Freq Bias Noise dB	Overall Level	Attenuator Loss dB	After Attenuator dB	Overall Level
63Hz	50		4	46	
125Hz	55		6	49	
125Hz	60		9	51	
500Hz	60	76.8	10	50	64.7
1000Hz	60		15	45	
2000Hz	65		13	52	
4000Hz	70		14	56	
8000Hz	75		12	63	

Attenuator Noise Level Reduction 12.2dB

Low frequency biased noise (Example generator set)

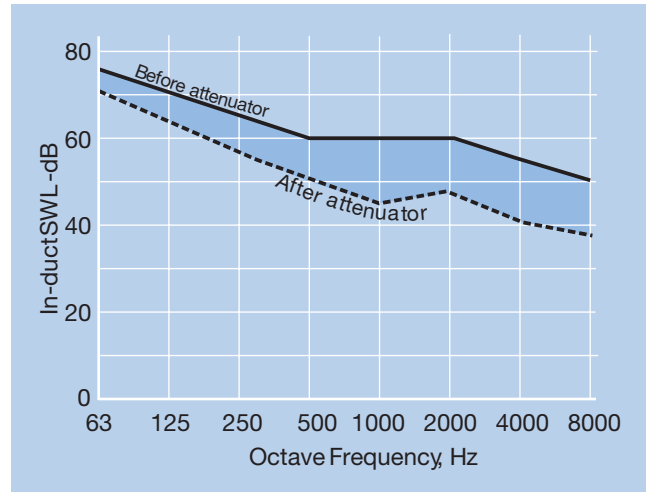
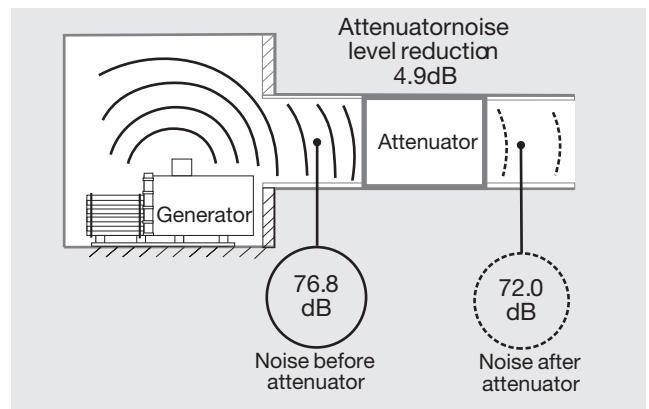

	Low Freq Bias Noise dB	Overall Level	Attenuator Loss dB	After Attenuator dB	Overall Level
63Hz	75		4	71	
125Hz	70		6	64	
125Hz	65		9	56	
500Hz	60	76.8	10	50	72.0
1000Hz	60		15	45	
2000Hz	60		13	47	
4000Hz	55		14	41	
8000Hz	50		12	38	

Attenuator Noise Level Reduction 4.9dB

ATTENUATOR SELECTION PROCEDURE

2. Attenuator Pressure Loss

A sound attenuator restricts the passage of airflow through it. The restriction of the attenuator is defined in Pa of static pressure loss. The pressure loss of the attenuators in this catalogue is charted in two different ways:

a) Pressure loss at a given airflow

For the C, C.P, CC series circular attenuators and POW series attenuators, the static pressure loss is charted for each model at different airflows. For example, if we select an attenuator model C2P-071 with an airflow of 4m³/s, the pressure loss is 50Pa.

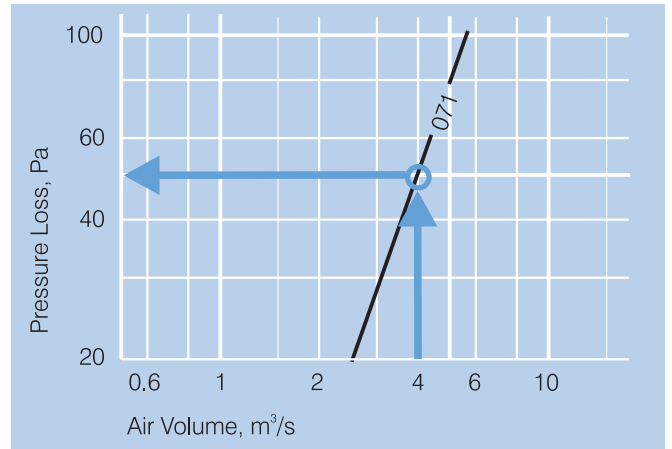

b) Variable Face Area (Width or Height)

Some attenuator types are expected to be built to varying widths and heights to suit the duct or wall sizing. With acoustic louvres for example, pressure losses for a given model are graphed against face velocity:

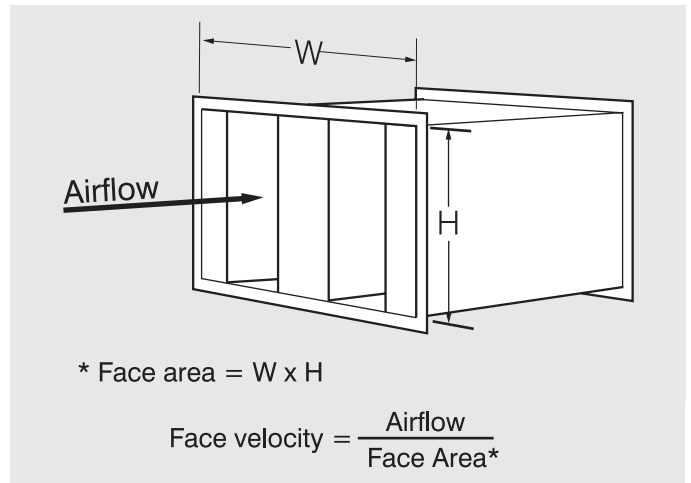
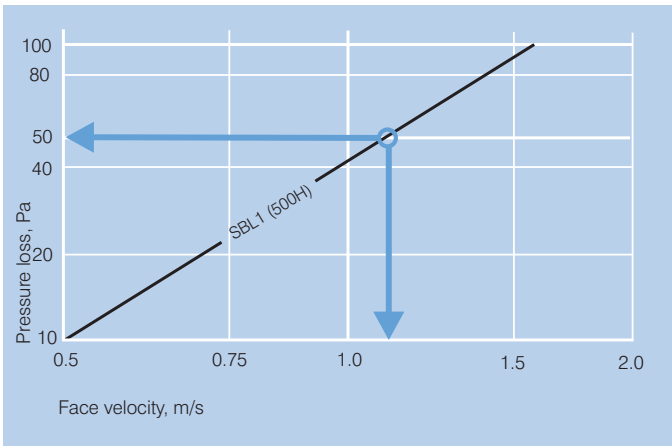

For rectangular attenuators, the velocities are provided for a given model at 20Pa or 50Pa at different lengths as per below:

(See Page H-7)

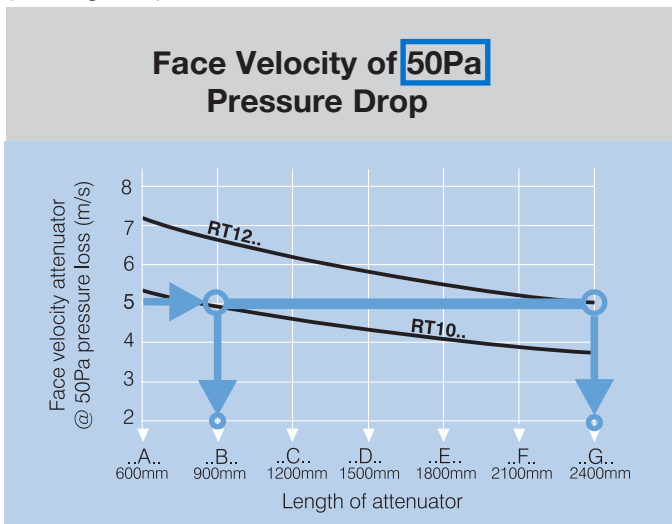

RECTANGULAR DUCT ATTENUATORS



R3T Series - Rectangular Thick Wall Attenuators

The R3T series of attenuators is suitable for HVAC purposes and ideal for industrial applications. They have wider splitters providing better low-frequency attenuation than the standard RT series. This makes them more suitable for the control of low-frequency noise emissions such as those from generator sets and pump systems.

Sectional Representation



RT Series
Standard splitters



RT..QS Series
Splitters with infill wrapped in impermeable film



R3T Series
Thicker splitters

Description

Elta Rectangular Attenuators are available in different models to suit a variety of applications and duct dimensions. They can be made in different widths and heights, and each model number denotes a different percentage open area and length combination.

The rectangular attenuators are available in the following models:

RT Series - Rectangular Attenuators

The RT series is ideal for general HVAC purposes and suitable for industrial applications. These attenuators deliver good acoustic attenuation properties across a broad spectrum of sound frequencies while maintaining low airflow pressure drops through the attenuator. This range is suitable for dry applications. Refer to the RT..QS series for applications where moisture may be present in the air stream.

RT..QS Series - Rectangular Q-Seal Attenuators

The Rectangular Q-Seal attenuator includes the qualities of the RT series attenuator and incorporates an infill system fully wrapped in an impermeable plastic membrane/film. The RT..QS Series is suitable in medical and clean room applications and any sensitive ventilation systems requiring a wrapped infill material to prevent the possibility of insulation fibre ingress into the airstream. They are also suitable where the insulation medium is directly exposed to weather, grease, liquid or dusts. Attenuators of this model type may also be cleaned periodically by low-pressure steam or pressure washer equipment.

Construction

- Casing and splitters made from Z275 coated galvanized steel.
- Infill from bio-soluble acoustic grade glasswool or mineral wool, encased behind finely perforated galvanized steel. Infill is hygroscopic and incombustible.
- RT and R3T Series have a fiberglass membrane between infill and perforated steel layer to minimize fibre egress from the infill into the air stream.
- Q-Seal (QS) variants have infill material fully wrapped in liquid impermeable Melinex PET Plastic Film.
- Standard construction rated to duct pressures between -500Pa and +1kPa relative to atmosphere.

How To Order

RT - Tapered splitter

R3T - Wide tapered splitter

Airway width code

07 - 75mm	15 - 150mm	22 - 225mm
10 - 100mm	17 - 175mm	25 - 250mm
12 - 125mm	20 - 200mm	30 - 300mm

Length code

A - 600mm	D - 1500mm	G - 2400mm
B - 900mm	E - 1800mm	
C - 1200mm	F - 2100mm	

QS - with Q-seal

(Default is standard construction)

Casing width in cm.

Casing height in cm.

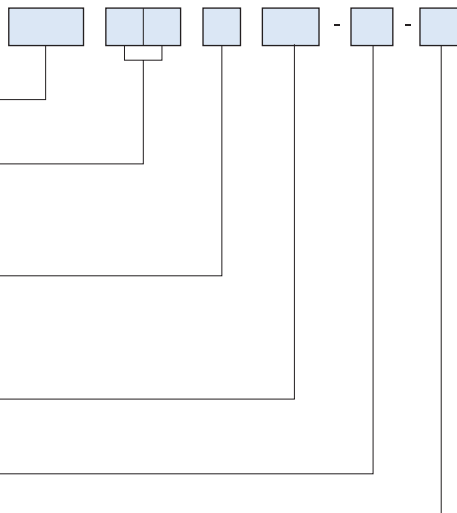

Dimensions

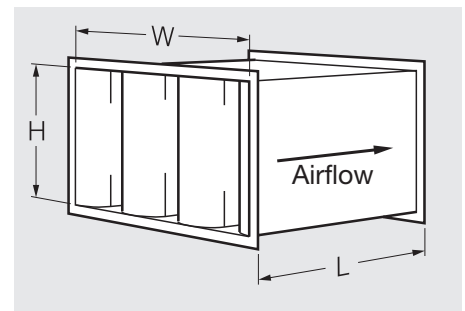

RECTANGULAR DUCT ATTENUATORS

Sectional Sizing & Joining Flange Information

- Flanges 35mm TDF or compatible up to a maximum height or width of 1200mm. Above these sizes 40mm or 50mm steel angle section frames used, supplied undrilled.
- Matching flanges for attaching to accompanying ductwork can also be supplied.
- Rectangular attenuators will typically be made in a single piece up to a maximum of 2250mm in width, length or height. Above this dimension attenuators will be split into multiple sections in the dimension(s) exceeding the 2250mm limit noted.
- As a special request, attenuators may be divided into smaller sized sections than standard to fit through small spaces, before they are reassembled as a single unit on site.

Customised Attenuator Options

The following are available as special options when ordering Elta rectangular attenuators:

- Different materials of construction such as Stainless Steel Grades 304 and 316.
- Paints / protective coatings such as epoxy paint, Chlorinated Rubber etc.
- Flange material/dimensions profile can be specified e.g. Ductmate, TDF, Plain Steel Angle.
- Access doors for easy cleaning (e.g. in Kitchen Exhaust Applications).

Suggested Specification

Rectangular attenuators shall be of the RT, R3T or RT..QS Series as designed and manufactured by Elta and shall have the dimensions, acoustic attenuator insertion losses and pressure losses as scheduled. Acoustic Attenuator Insertion Loss data for the attenuators to be derived from tests in accordance to BS4718:1971.

The casing shall be manufactured from forming grade zinc-coated mild steel sheet with Pittsburgh corner seams.

The infill material shall be either rockwool or fibreglass as specified by the manufacturer. The infill material shall be covered with a membrane to prevent erosion of the fibres, then encased in galvanised perforated sheet metal. Where attenuators are exposed to the weather they shall be of the RT..QS Series where all infill materials shall be lined with an impervious film to prevent the ingress of moisture.

The infill material when tested in accordance with AS1530.3:1989 shall have the following indices:

Ignitability	0
Spread of flame	0
Heat evolved	0
Smoke developed	0

RECTANGULAR DUCT ATTENUATORS

Example: How to select a rectangular attenuator

For this scenario, noise from a car park exhaust fan results in a noise level of 83dB(A) in the car park it ventilates. The exhaust air volume passing through the fan is 7m³/s. The user would like to have a target noise level in the carpark of 60dB(A). Also, the attenuator can be no longer than 2200mm long, is not exposed to the weather, and can have no more than 20Pa of air flow resistance through it to avoid affecting the fan selection.

- 1 Select the appropriate noise reduction data column. Exhaust fan noise would be classified as 'General Fan noise'.
- 2 Choose the attenuator series required. Both the RT and R3T models would be appropriate as the internals of the attenuator are not exposed to the weather.
- 3 The noise reduction required is found by subtracting the target noise level from the current noise level.
83dB(A) Current noise level - 60dB(A) Target noise level = 23dB(A) reduction required.

Under the "General fan noise dB(A) reduction" columns for the attenuator series (RT & R3T) chosen earlier, follow the line sequence until the reduction noise (23 dB(A)) is found or marginally exceeds this number.

- 4 To achieve a 23 dB(A) noise reduction using the RT series, the following length and % open area combinations can be used; 2100mm/37%, 1800mm/33% and 1500mm/26%. For our example going forward, we will use the 2100mm long, 37% open area option. The selection closest to the top is normally the best from a price perspective. To evaluate other options, repeat the steps from 4 onwards.

Acoustic Performance Data

Length mm	% open area	General fan noise dB(A) reduction			Low Frequency biased noise dB(A) reduction			Product Codes		
		R3T.. Series	RT.. Series	RT..QS Series	R3T.. Series	RT.. Series	RT..QS Series	R3T.. Series	RT.. Series	RT..QS Series
2400	26	32	28	24	19	17	16	RT07G	RT07GQS	
	33	25	24	20	17	16	R3T15G	RT10G	RT10GQS	
	37	22	22	19	17	15	R3T17G	RT12G	RT12GQS	
	43	18	22	19	17	15	R3T22G	RT15G	RT15GQS	
	50	14	19	17	15	14	13	R3T30G	RT20G	RT20GQS
2100	26	30	26	21	18	16	RT07F	RT07FQS		
	33	24	23	19	17	16	R3T15F	RT10F	RT10FQS	
	37	21	23	18	16	15	R3T17F	RT12F	RT12FQS	
	43	17	21	16	15	14	R3T22F	RT15F	RT15FQS	
	50	12	17	14	13	12	12	R3T30F	RT20F	RT20FQS
1800	26	27	24	18	16	14	RT07E	RT07EQS		
	33	22	21	17	15	14	R3T15E	RT10E	RT10EQS	
	37	19	21	16	14	13	R3T17E	RT12E	RT12EQS	
	43	16	19	14	13	12	R3T22E	RT15E	RT15EQS	
	50	12	16	12	11	11	R3T30E	RT20E	RT20EQS	
1500	26	25	22	15	13	12	RT07D	RT07DQS		
	33	20	22	14	12	11	R3T15D	RT10D	RT10DQS	
	37	17	20	12	11	11	R3T17D	RT12D	RT12DQS	
	43	14	18	10	10	9	R3T22D	RT15D	RT15DQS	
	50	11	14	10	10	9	R3T30D	RT20D	RT20DQS	
1200	26	22	19	12	11	10	RT07C	RT07CQS		
	33	17	19	11	10	9	R3T15C	RT10C	RT10CQS	
	37	15	17	10	9	9	R3T17C	RT12C	RT12CQS	
	43	12	16	9	9	8	R3T22C	RT15C	RT15CQS	
	50	9	13	9	8	8	R3T30C	RT20C	RT20CQS	
900	26	18	15	10	8	7	RT07B	RT07BQS		
	33	14	16	10	8	7	R3T15B	RT10B	RT10BQS	
	37	12	14	9	8	6	R3T17B	RT12B	RT12BQS	
	43	10	13	8	7	6	R3T22B	RT15B	RT15BQS	
	50	7	10	7	6	5	R3T30B	RT20B	RT20BQS	
600	26	14	10	7	5	4	RT07A	RT07AQS		
	33	10	11	6	5	4	R3T15A	RT10A	RT10AQS	
	37	9	10	6	5	4	R3T17A	RT12A	RT12AQS	
	43	7	9	6	5	3	R3T22A	RT15A	RT15AQS	
	50	6	7	5	4	3	R3T30A	RT20A	RT20AQS	

Acoustic performance tests to ISO7235-2003 that have been simplified to single digit noise reduction levels are shown in table above.

Detailed attenuator insertion loss (SIL) spectrums based on testing to the BS4718-1971 Standard can be obtained using the Intelligent Ventilation Product Selection Program.

RECTANGULAR DUCT ATTENUATORS

- 5) Select the product code which is aligned with the 2100mm long, 37% open, 23 dB(A). In this case the product code is RT12F.
- 6) Refer to the correct pressure loss (20Pa) graph and attenuator series (RT Series for the RT12F model)
- 7) Draw a vertical line on the graph that corresponds to the length of the attenuator model chosen at step 4 (i.e. 2100mm long or 'F' length code). The face velocity on the RT12../QS curve that corresponds to the model is 3.3m/s

6) Face Velocity at 20Pa Pressure Drop

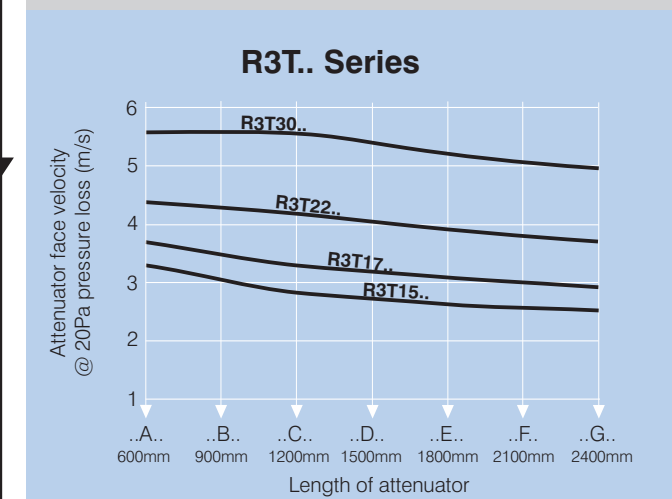
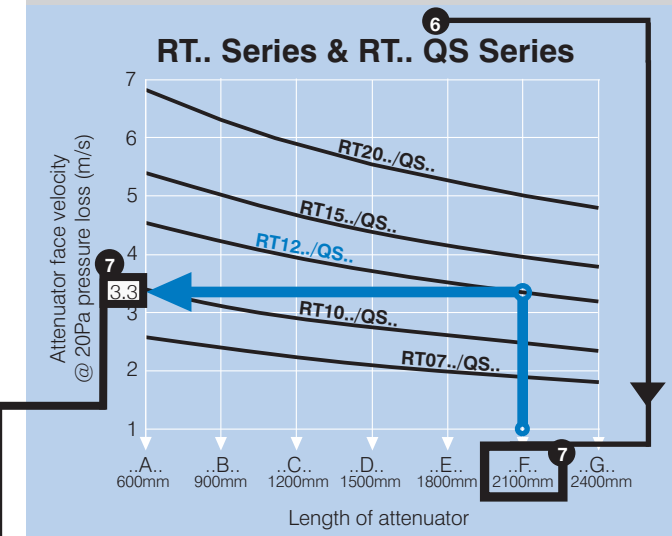

Face Velocity at 50Pa Pressure Drop

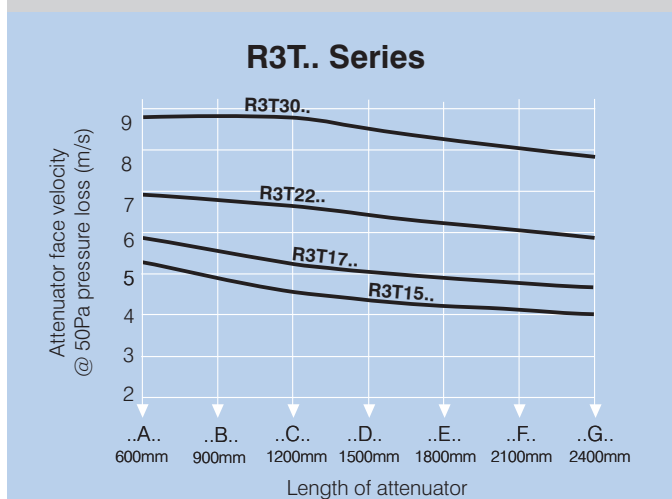
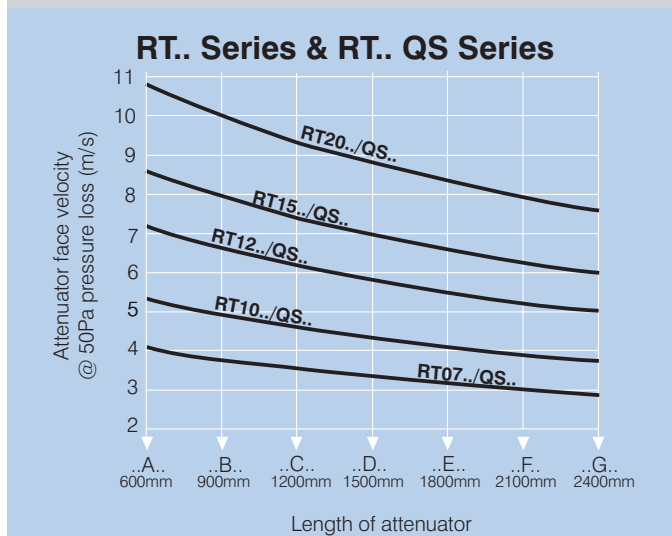

8) Calculate the minimum face area for your attenuator selection; $\text{Face Area} = \frac{\text{Airflow}}{\text{Face Velocity}} = \frac{7.0\text{m}^3/\text{s}}{3.3\text{m/s}} = 2.12\text{m}^2$

9) To calculate the width of a rectangular attenuator of unknown dimensions, use the formula;

$$\text{Width} = \sqrt{\text{Face Area} \times \text{Aspect Ratio}} = \sqrt{2.12\text{m}^2 \times 1.5} = 1.78\text{m}$$

*Common aspect ratios vary between 0.5 and 3.0. When a silencer width is larger than its height aspect ratio >1.0. An aspect ratio of 1.5 is a good default.

In the width table below, pick the closest width available for a RT12.. series attenuator. In this case, 1.95m (1950mm) is the selected width.

To calculate the height of the attenuator, use the formula; $\text{Height} = \frac{\text{Face Area}}{\text{Width}} = \frac{2.12\text{m}^2}{1.95\text{m}} = 1.09\text{m}$

The final model code of the attenuator selected is **RT12F-195-109**

Width table

R3T.. Series (mm)			
R3T15..	R3T17..	R3T22..	R3T30..
450	475	525	600
900	950	1050	1200
1350	1425	1575	1800
1800	1900	2100	2400
2250	2375		

RT.. Series (mm)				
RT07..	RT10..	RT12..	RT15..	RT20..
275	300	325	350	400
550	600	650	700	800
825	900	975	1050	1200
1100	1200	1300	1400	1600
1375	1500	1625	1750	2000
1650	1800	1950	2100	2400
1925	2100	2275		
2200	2400			

RT.. Q Seal Series (mm)				
RT07.. QS	RT10.. QS	RT12.. QS	RT15.. QS	RT20.. QS
275	300	325	350	400
550	600	650	700	800
825	900	975	1050	1200
1100	1200	1300	1400	1600
1375	1500	1625	1750	2000
1650	1800	1950	2100	2400
1925	2100	2275		
2200	2400			

CIRCULAR DUCT ATTENUATORS

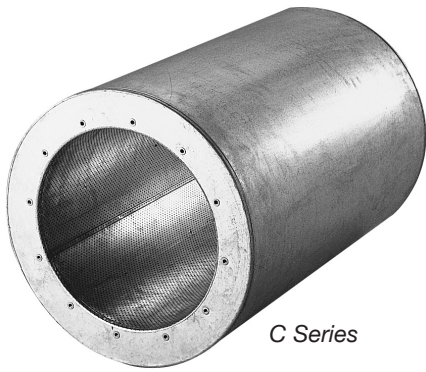

C Series



CP Series

Description

Elta Circular duct attenuators are designed to be directly attached to fans or in-line with circular ductwork.

The range of circular attenuators is as follows:

C Series - Open Circular Attenuators

Ideal for most HVAC and industrial applications. Available in fixed internal diameters with two lengths, nominally one or two times the inner diameter of the attenuator. They produce nominal increases in airflow pressure drop over plain duct. This range is suitable for dry applications. Refer to the C..QS and C.P..QS Series for applications where moisture may be present in the air stream.

C.P Series - Podded Circular Attenuators

The C Series circular attenuator can be fitted with a full length acoustically absorptive pod. Ideal for applications where additional acoustic performance is required over the C Series and higher airflow pressure loss can be accepted (see H-10).

C..QS and C.P..QS Series - Circular Q-Seal Attenuators

The Circular Q-Seal attenuators include the qualities of the C and C.P series attenuators and incorporate an infill system fully wrapped in an impermeable plastic membrane/film. The C..QS and C.P..QS Series are suitable in medical and clean room applications and any sensitive ventilation systems requiring a wrapped infill material to prevent the possibility of insulation fibre ingress into the airstream. They are also suitable where the insulation medium is directly exposed to weather, grease, liquid or dusts. Attenuators of these model types may also be cleaned periodically by low-pressure steam or pressure washer equipment.

Construction

- Casing and structure made from Z275 zinc coated galvanized steel.
- Alternative material of construction available including SS304, SS316 and 5000 Series Aluminium.
- Infill from bio-soluble acoustic grade glasswool or mineral wool.
- C Series has a fiberglass membrane to minimize fibre egress from the infill into the air stream.
- Q-Seal variants have infill material fully wrapped in PET plastic film.

Performance Data

Acoustic and Performance Data sheets based on Testing to BS4718:1971 may be accessed by using the 'Intelligent Ventilation' Product Selection Program.

Suggested Specification

Circular attenuators shall be of the C Series as designed and manufactured by Elta and shall have the dimensions, acoustic insertion losses and pressure losses as scheduled. Casing and end flanges shall be constructed from forming grade zinc-coated mild steel sheet. The infill material shall be either rockwool or fibreglass as specified by the manufacturer. The infill material shall be covered with a gauze scrim to prevent erosion of the fibres, then encased in galvanised perforated sheet metal.

How To Order

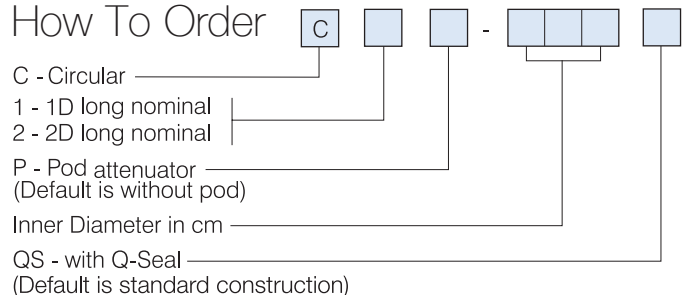



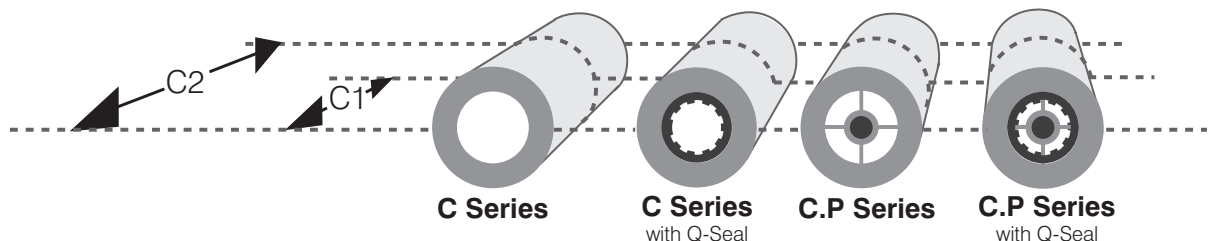













Range Available



CIRCULAR DUCT ATTENUATORS

Acoustic Performance Data

	General fan noise dB(A) reduction*				Low Frequency biased noise dB(A) reduction*			
Standard Series								
Models C1... C1P... C2... C2P...	C1... Standard Series	C1P... Standard with Pod Series	C2... Standard Series	C2P... Standard with Pod Series	C1... Standard Series	C1P... Standard with Pod Series	C2... Standard Series	C2P... Standard with Pod Series
...-031	9	14	14	20	5	8	8	12
...-035	9	14	15	20	5	8	9	12
...-040	9	15	15	20	5	8	9	12
...-045	9	15	15	20	5	8	9	12
...-050	9	15	15	21	5	8	9	13
...-056	9	15	16	21	6	8	10	13
...-063	10	15	16	23	6	9	10	14
...-071	10	15	16	23	7	9	11	14
...-080	10	15	16	23	7	9	11	14
...-090	9	15	14	23	7	10	11	15
...-100	9	15	15	23	7	10	11	15
...-125	9	15	14	22	8	10	11	15
...-140	9	14	14	22	8	10	13	16
...-153	8	13	13	22	9	10	12	18
...-160	8	13	13	22	9	10	12	18
...-180	8	13	12	22	9	10	12	18
...-200	8	13	12	22	9	10	12	18
Q-Seal Series								
Models C1...QS C1P...QS C2...QS C2P...QS	C1...QS Q-Seal Series	C1P...QS Q-Seal with Pod Series	C2...QS Q-Seal Series	C2P...QS Q-Seal with Pod Series	C1...QS Q-Seal Series	C1P...QS Q-Seal with Pod Series	C2...QS Q-Seal Series	C2P...QS Q-Seal with Pod Series
...-031	6	12	12	17	4	7	7	10
...-035	6	12	12	17	4	7	7	10
...-040	6	12	12	17	4	7	7	10
...-045	7	12	12	17	4	7	7	10
...-050	7	12	12	18	4	7	7	10
...-056	7	12	13	18	4	7	8	10
...-063	7	13	13	20	5	7	8	12
...-071	7	13	13	20	5	7	9	12
...-080	7	12	13	20	5	7	9	12
...-090	7	12	12	19	6	8	9	12
...-100	7	12	12	19	6	8	9	13
...-125	6	12	12	18	6	8	9	13
...-140	6	11	11	18	6	8	10	14
...-153	6	10	10	18	7	8	10	15
...-160	6	10	10	18	7	8	10	15
...-180	6	10	10	18	6	8	10	15
...-200	6	10	10	18	6	8	10	15

* See pages H-2 and H-3 for more information on general fan noise reduction and low frequency bias noise reduction.

CIRCULAR DUCT ATTENUATORS

Pressure Drop Graphs

Podded Circular Attenuator - C1P..., C2P..., C1P...QS, C2P...QS

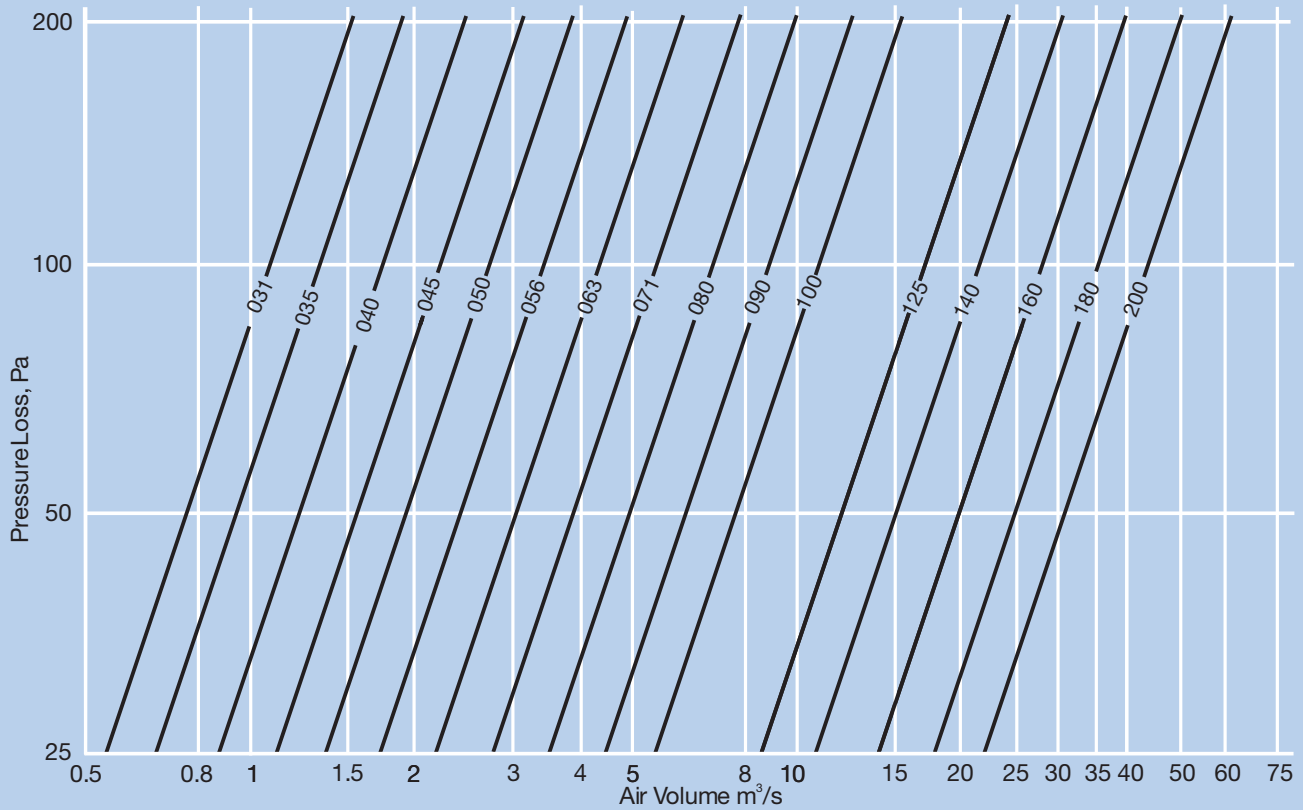

Open Circular Attenuator - C1..., C2..., C1...QS, C2...QS

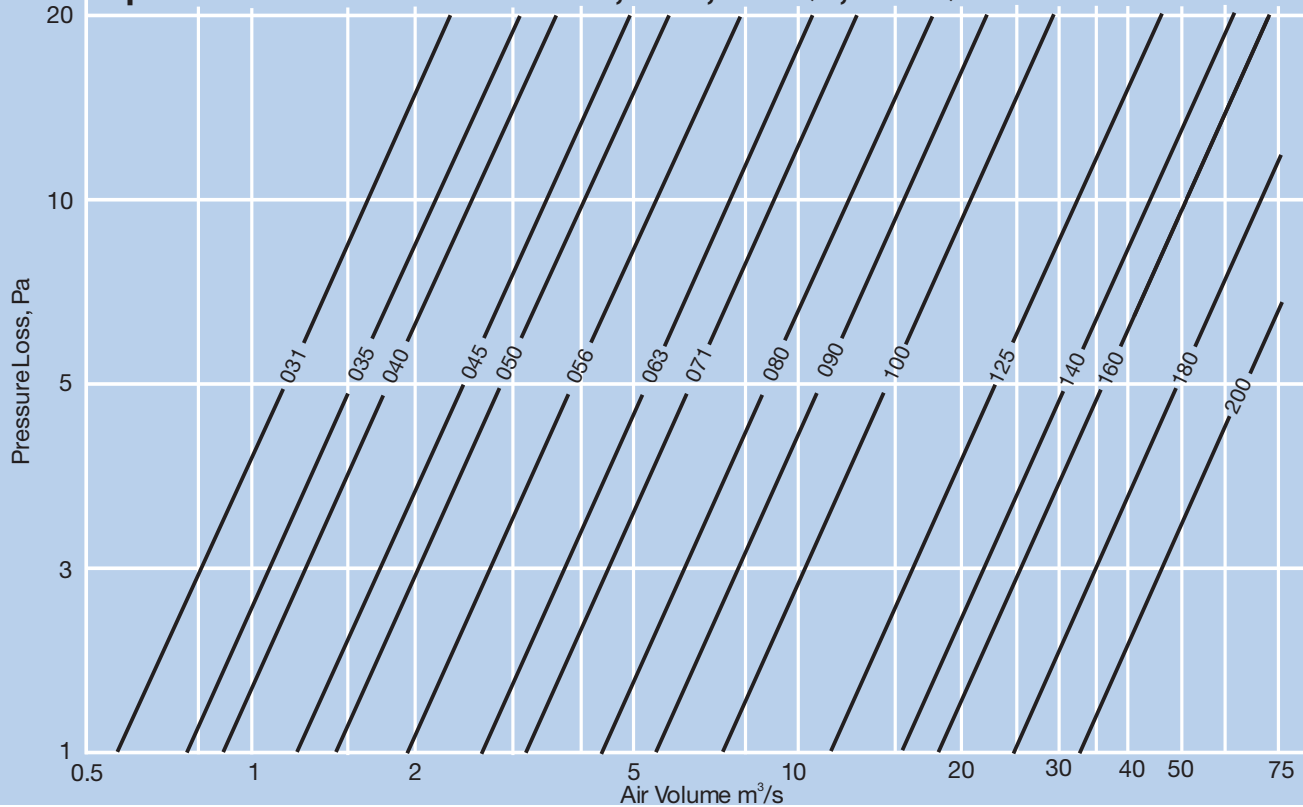

CIRCULAR DUCT ATTENUATORS

Dimensions & Weight

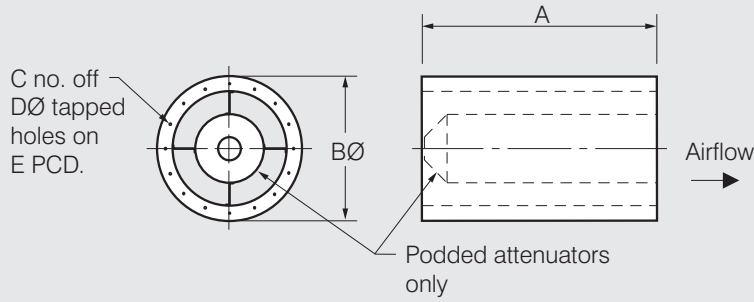

Model	A		Dimensions, mm				Approx. weight, kg*			
	C1-Dia.	C2-Dia.	BØ	C	DØ	E	Open		Pod	
C1P-Dia.	Type C1	Type C2					C1	C2	C1P	C2P
C2P-Dia.	C1P	C2P								
-031	300	600	481	8	M6	355	13	26	15	30
-035	300	600	521	8	M6	395	14	28	16	32
-040	600	900	566	8	M8	450	23	34	25	38
-045	600	900	616	8	M8	500	25	38	33	50
-050	600	1150	666	12	M8	560	27	52	36	70
-056	600	1150	730	12	M8	620	30	57	41	75
-063	600	1150	800	12	M8	690	34	64	47	90
-071	900	1500	880	16	M8	770	50	83	70	116
-080	900	1500	970	16	M8	860	55	92	78	130
-090	1150	1800	1070	16	M8	970	74	116	106	166
-100	1150	1800	1220	16	M10	1070	90	140	127	198
-125	1150	2400	1470	20	M10	1320	110	229	158	329
-140	1150	2400	1620	20	M10	1470	122	254	177	369
-160	1800	3600	1820	24	M12	1680	195	389	286	571
-180	1800	3600	2020	24	M12	1880	217	434	321	642
-200	1800	3600	2220	24	M12	2080	241	482	357	713

*To determine weights of Q-Seal attenuators multiply the weights shown above by 0.85

SOUND BAR LOUVRES



ASB

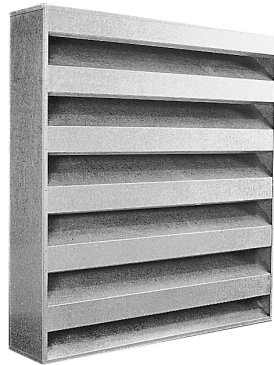

SBL1



SBL2

Description

The acoustic sound bar louvre range has been designed to efficiently allow air to pass through a building facade while reducing/preventing noise from escaping outside the building. They are a high quality, proven and tested solution that are available in 200, 300 and 600mm depths, from 200 to 2400mm widths and a large range of heights.

Features

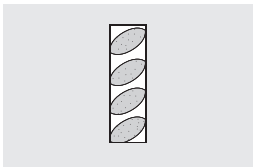

ASB Aerosound

- Aerosound blade profile reduces pressure loss by 40% over conventional louvre designs.
- Lower pressure loss allows for louvre to be selected at reduced widths and heights.
- Only 200mm deep - takes up minimal space in a plant room.
- Open area ranges from 16 to 24% for optimal acoustic performance.

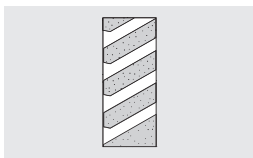

SBL1

- 120mm thick louvre blade for superior low-frequency attenuation.
- Includes Rain-Lip for enhanced weather proofing in tropical climates.
- Open area ranges from 20 to 36%.

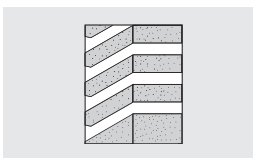

SBL2

- Highest noise reduction performance
- Includes Rain-Lip for enhanced weatherproofing in tropical climates.
- Open area ranges from 20 to 36%.

Typical Applications

Allows outside air to enter HVAC plant rooms, fire pump rooms, generator rooms and return air intakes in commercial and industrial applications.

Construction

Casing and structure made from Z275 zinc coated steel.

Can also be made from other material including SS304 and SS316 stainless steel, and 5000 series grade aluminium.

Infill made from bio-soluble, acoustic grade glasswool or mineral wool.

Suitable for weather exposure on outside face only.

Testing

Acoustic performance data as per testing to AS1191-1985 and ISO7235-2003

Airflow pressure loss data as per testing in facility to BS848:Part 1-1980 or ISO5801-2007

Suggested Specification

The acoustic louvres shall be of the ASB or SBL1 or SBL2 Series as designed and manufactured by Elta and be of the model numbers shown on the schedule/drawings. Acoustic Louvres are to be weather resistant externally and infill material is to be separated from the air stream with a fibre-loss reducing membrane. Acoustic performance data of all louvres to be as per tests to AS1191:1985 or ISO7235-2003 and airflow pressure loss data must be verified by testing to BS848:Part 1-1980 or ISO5801-2007.

How To Order

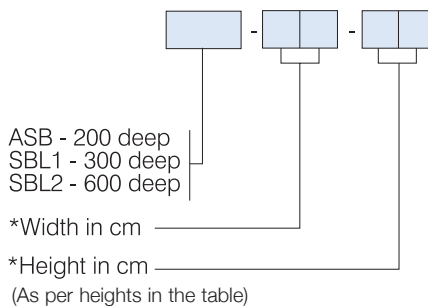

*When ordering, allow for 10mm all around the louvre to accommodate for site discrepancies.

Special options eg. epoxy paint, should be clearly nominated at the time of order.

SOUND BAR LOUVRES

Weights

ASB Aerosound



Height, mm	Weights(kg) for width of				% Free Area
	500mm (Kg)	1000mm (Kg)	1500mm (Kg)	2000mm (Kg)	
500	11	19	28	36	16.0
750	16	28	40	52	19.0
1000	21	36	52	67	20.0
1275	26	45	64	83	23.0
1525	31	53	75	98	23.0
1800	35	61	87	113	24.0
2050	40	70	99	129	24.0
2300	45	78	111	144	24.0

SBL1

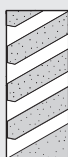

Height, mm	Weights(kg) for width of				% Free Area
	500mm (Kg)	1000mm (Kg)	1500mm (Kg)	2000mm (Kg)	
500	13	23	33	43	20.0
750	20	35	50	65	26.7
1000	27	47	67	87	30.0
1250	34	59	84	109	32.0
1500	41	71	101	131	33.3
1750	48	83	118	153	34.3
2000	55	95	135	175	35.0
2250	62	107	152	197	35.6

SBL2

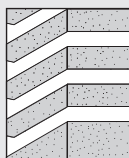

Height, mm	Weights(kg) for width of				% Free Area
	500mm (Kg)	1000mm (Kg)	1500mm (Kg)	2000mm (Kg)	
500	24	43	61	80	20.0
750	37	65	93	120	26.7
1000	50	87	124	161	30.0
1250	63	109	155	202	32.0
1500	76	131	187	242	33.3
1750	89	154	218	283	34.3
2000	102	176	250	324	35.0
2250	116	198	281	364	35.6

Dimensions



Dimensions in mm

SOUND BAR LOUVRES

Mounting Arrangements

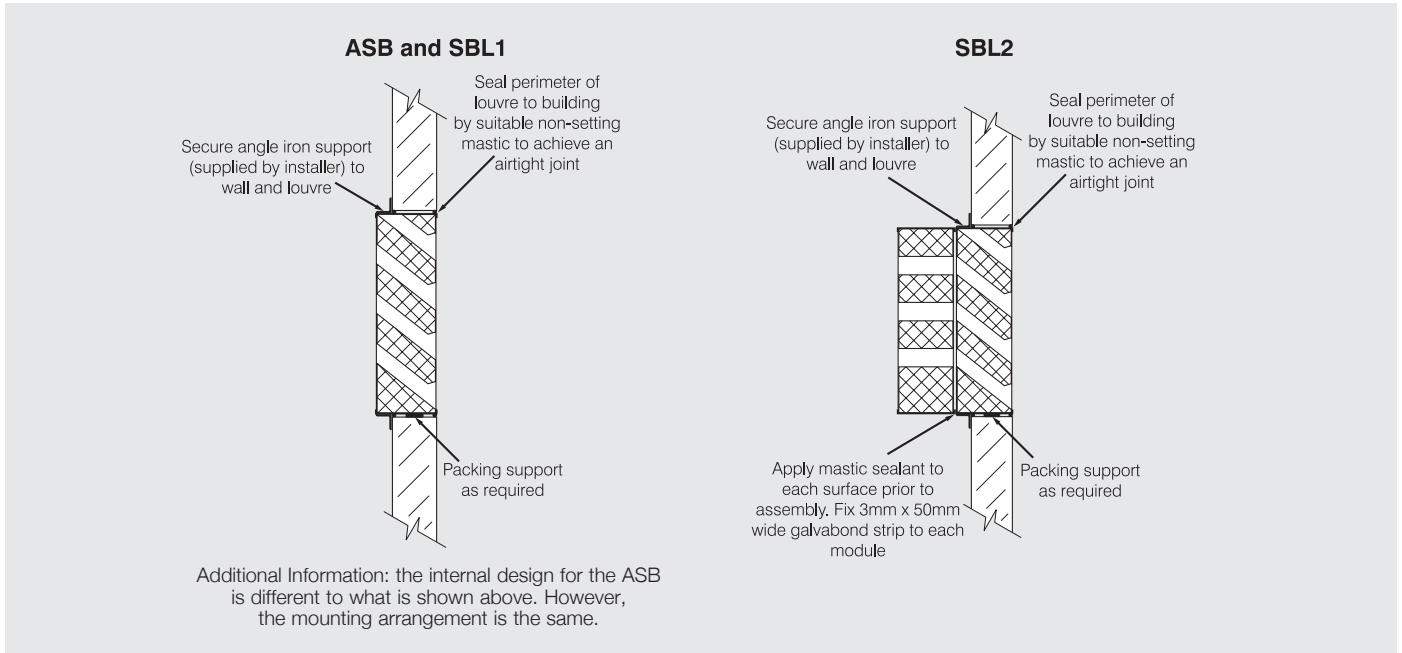

Acoustic Performance

Model		Static Insertion Loss, dB								dB(A) Reduction*	
		Octave Band Centre Frequency (Hz)								Low Frequency	General HVAC
		63	125	250	500	1k	2k	4k	8k		
ASB	STL	1	3	7	11	12	10	10	9	5.8	9.8
	NR	7	9	13	17	18	16	16	15	-	-
SBL1	STL	4	7	9	13	14	12	12	8	8.6	11.9
	NR	10	13	15	19	20	18	18	14	-	-
SBL2	STL	5	10	14	22	27	25	21	17	12.7	19.9
	NR	11	16	20	28	33	31	27	23	-	-

NR - Noise reduction STL - Sound transmission loss

Refer to the 'General Acoustic Information Section' for further detail on NR and STL rating.

* See 'Attenuator Selection Procedure' on page H2/3 for further information on dB(A) reduction.

Pressure Drop Graph

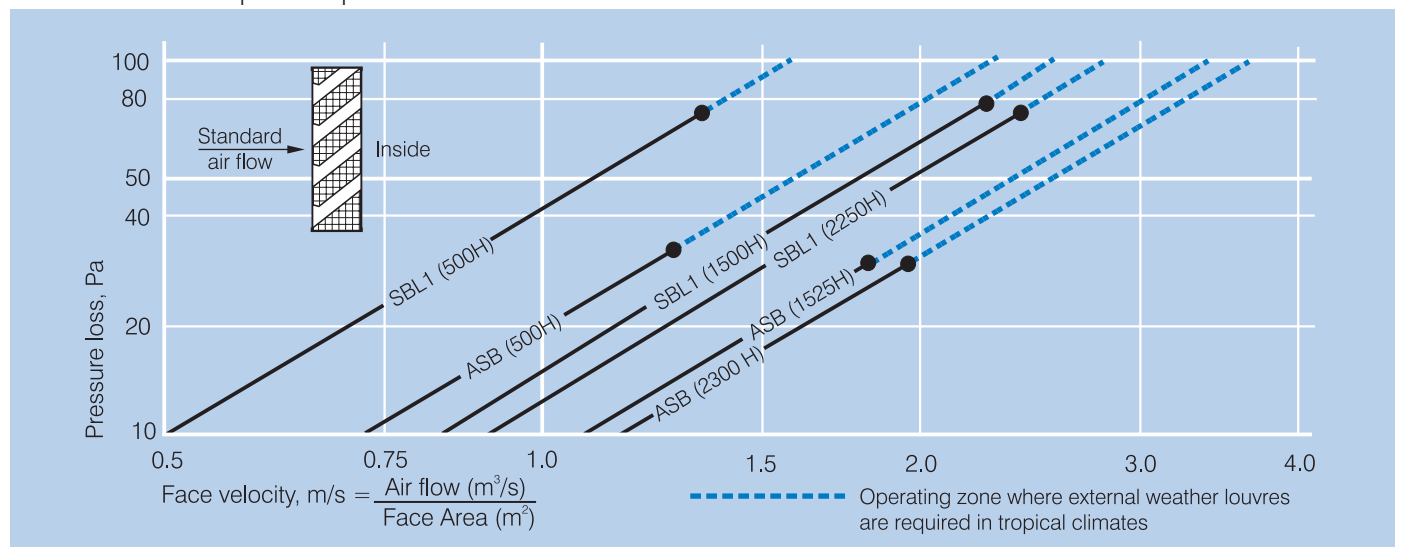

Additional Information: For SBL2 pressure losses, multiply SBL1 losses by 1.03.

For reverse airflow on SBL1 & SBL2 models, multiply pressure loss by 1.3.

For ASB models, pressure loss is the same for both airflow directions.

CC SERIES CIRCULAR ATTENUATORS



Description

The Q-Tech high performance CC Series circular attenuators are a popular solution for reducing the noise of smaller HVAC systems utilising round duct.

Units are lightweight, spun end caps are designed for easy connection to a fan or ductwork. Connecting ductwork can be rigid or flexible, matching spigot sizes.

CC attenuators are ideal in situations where more acoustic performance is required than what can be obtained with a suitable length of acoustic flexible duct and cost precludes the use of lined metal duct.

Where breakout noise is a critical design parameter refer to the Rectangular and Circular Series Attenuators.

Testing

All units have been tested in accordance with BS4718:1971 for insertion loss. Airflow pressure loss data obtained from tests conducted on a BS848:Part 1, 1980 test rig.

Suggested Specification

Circular attenuators shall be of the CC-Series as designed and manufactured by Elta and shall have the dimensions, acoustic attenuator insertion losses and pressure losses as scheduled.

How To Order

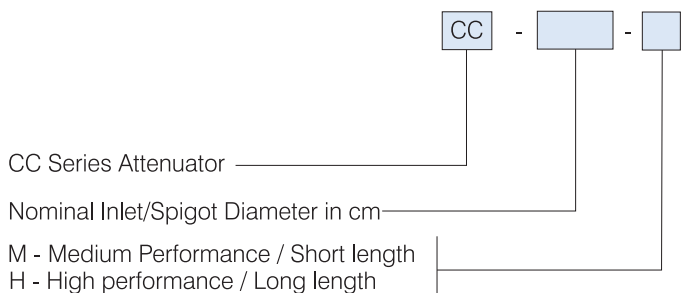

Pressure Drop Graph

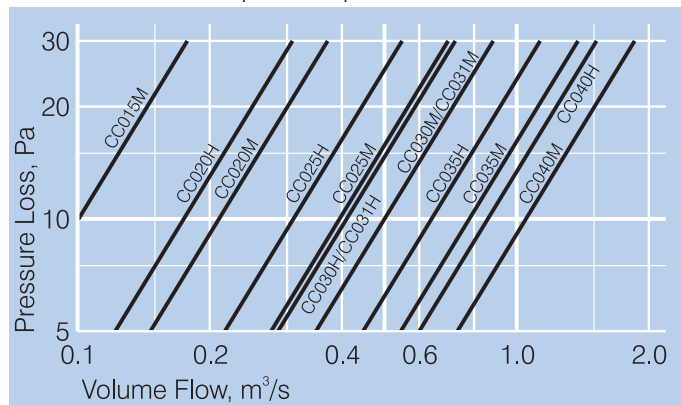

Model No. CC...	Static Insertion Loss, dB								Approx. dB(A) reduction
	Octave Band Centre Frequency (Hz)								
	63	125	250	500	1k	2k	4k	8k	
015M	7	9	10	18	23	38	22	19	16-19
020M	3	5	9	17	37	22	15	13	14-18
020H	7	7	11	21	44	33	17	15	16-22
025M	1	3	5	12	27	15	10	9	9-14
025H	5	5	9	19	39	21	11	10	13-19
030M	4	4	8	18	32	16	9	7	11-22
030H	5	7	10	26	44	23	11	10	13-24
031M	4	4	8	18	32	16	9	7	11-22
031H	5	7	10	26	44	23	11	10	13-24
035M	3	3	7	17	27	12	8	6	12-15
035H	4	6	10	24	38	17	9	9	15-18
040M	2	3	6	16	21	10	6	5	11-14
040H	4	6	9	23	31	16	8	7	14-17

Dimensions

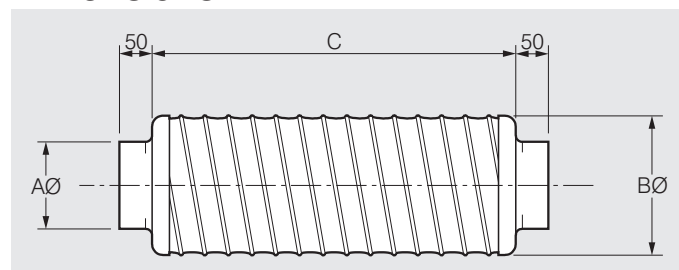

Model No. CC...	Dimensions, mm			Approx. wt. kg
	AØ	BØ	C	
015M	150	265	500	1.6
020M	200	320	500	1.8
020H	200	320	1000	3.6
025M	250	365	500	1.9
025H	250	365	1000	3.8
030M	300	415	1000	4.0
030H	300	415	1500	6.0
031M	315	415	1000	4.1
031H	315	415	1500	6.1
035M	350	465	1000	4.3
035H	350	465	1500	6.4
040M	400	515	1000	4.7
040H	400	515	1500	7.0

Comparison Test

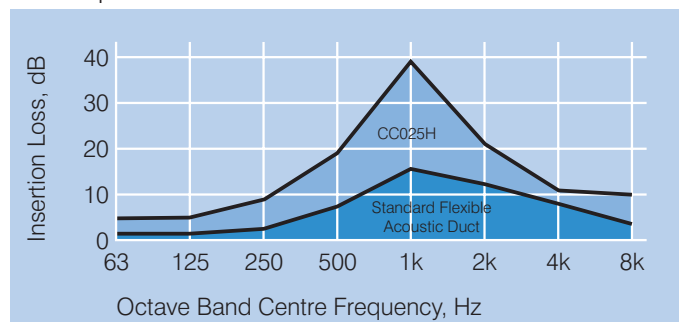

* The above illustrates the superior performance of the 'CC' range when compared to standard flexible acoustic duct of equal length. Both products were tested on the same test rig.

POWERLINE SERIES RECTANGULAR DUCT ATTENUATORS



Description

Matching attenuators designed to attach directly to the inlet and outlet of all PowerLine PCD/PCE series fans and selected Multiflow MMD/MME series fans.

Construction

Each PowerLine Attenuator is provided with a spacer duct to set the attenuator at an optimum distance from the fan. The attenuators are constructed with perforated metal and acoustic insulation internally similar to the RT series of rectangular attenuators. Custom lengths and open areas are chosen to suit the characteristics of the fans this product is designed to accompany.

Suggested Specification

Matching rectangular attenuator assemblies shall be of the POW Series as designed and manufactured by Elta and shall have the dimensions, acoustic attenuator insertion losses and pressure losses as scheduled. The attenuators shall be approved for use when directly mounted to a Elta In-Line Centrifugal or In-Line Mixed Flow fan.

How To Order

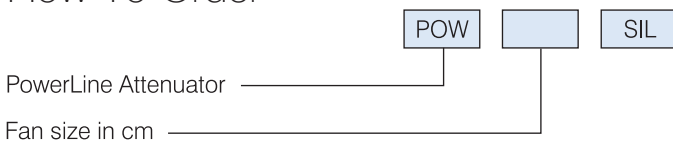

Pressure Drop Graph

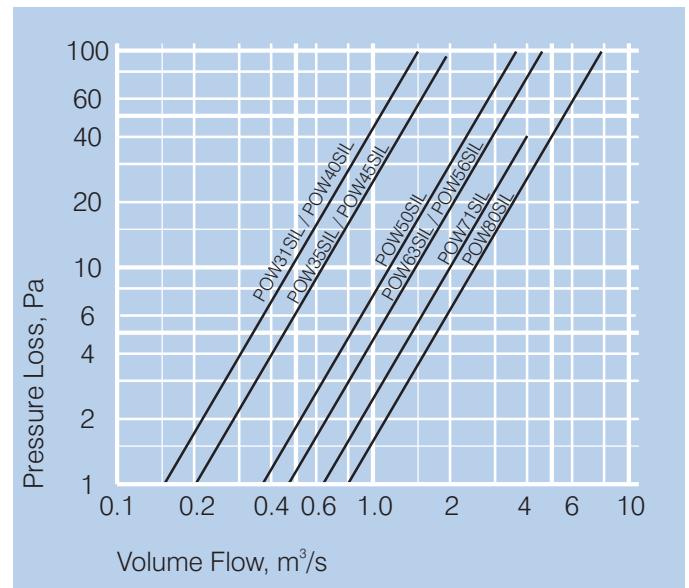

Dimensions

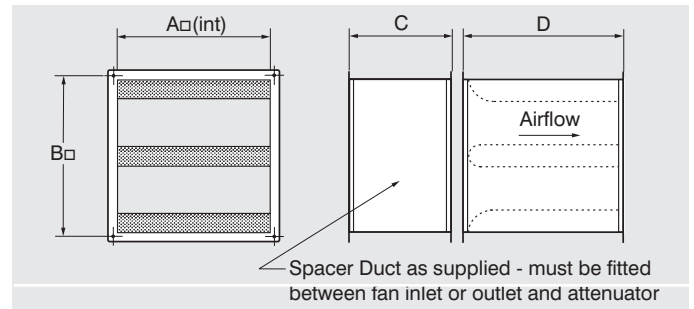

Model No.	Dimensions, mm				Attenuator Spacer		
	POW..SIL	A _o	B _o	C	D	wt. kg	wt. kg
31		400	425	400	600	20	8
35		450	475	400	900	32	9
40		500	525	400	900	53	10
45		550	575	400	900	56	11
50		650	675	600	1200	77	20
56		725	750	600	1200	89	22
63		800	825	600	1500	115	24
71		900	925	600	1500	152	27
80		1000	1025	600	1800	201	30

Selection Table

Model No.	PowerLine Series Fan PCD/E..	Multiflow Series Fan MMD/E..	Approximate dB(A) reduction*
POW...	(Pg. B-34/36)	(Pg. B-42/46)	
31SIL	PCD/E31...	MMD/E31.	6-8
35SIL	PCD/E35...	MMD/E35.	9-10
40SIL	PCD/E40...	MMD/E40.	11-15
45SIL	PCD/E45...	MMD/E45.	10-15
50SIL	PCD/E50...	MMD/E50.	10-15
56SIL	PCD/E56...	MMD/E56.	13-18
63SIL	PCD/E63...	MMD/E63.	13-18
71SIL	PCD/E71...	-	11-12
80SIL	-	MMD/E80.	15-17

* Approximate dB(A) reduction is for guidance only and depends largely on the noise profile of the attached fan. If exact noise spectrums are required, please contact your local sales office to obtain reductions for the model required.

CROSS-TALK ATTENUATORS



Description

The Q-Tech range of Cross-Talk attenuators has been designed to provide low airflow resistance whilst maintaining a high degree of acoustic attenuation.

The CT series should be considered wherever a relief air passage is required to penetrate a room's acoustic barrier.

Four styles are available in both standard and high performance configurations:

- CTS - for simple wall penetration above ceiling
- CTL - wall to ceiling penetration
- CTU - ceiling to ceiling penetration
- CTZ - installation within the wall

Installation - General

Special care should be taken when installing CT Series Cross-Talk units to ensure maximum performance.

Consideration must be given to the sound rating of the wall or ceiling being penetrated.

It is essential that a tight airseal is achieved between the cross-talk unit and the wall/ceiling penetration.

When high performance units are used additional mass lagging of the unit casing may be required to prevent flanking transmission. This can usually be provided by building-in the cross-talk unit during the building construction phase.

Performance

The Q-Tech CT Series acoustic performance is quoted as airborne sound transmission loss as defined in AS1191:1985.

Performance data is based on Australian sourced and manufactured products.

How To Select

Selection Procedure

1. Select the Cross-Talk attenuator type that is required ie. CTS, CTU etc.
2. Select high or standard performance attenuation as required.
3. When the relief air quantity is known, select from the Air Performance Data table below, the width and depth combination for your needs.
4. Determine final product code for ordering.

Air Performance Data

Depth, mm	Air Volume, L/sec						
	W-width, mm						
	300	450	600	750	900	1050	1200
200	90	135	180	225	270	315	360
300	135	200	270	340	400	475	540
400	180	270	360	450	540	630	720

The airflows tabulated are based upon a maximum pressure loss of 15 Pa.

How To Order

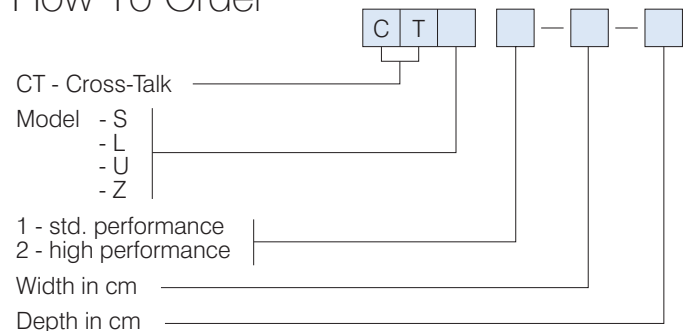

CROSS-TALK ATTENUATORS

Type: CTS

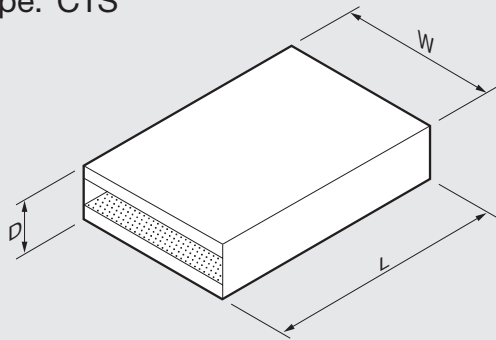

Model Number	Transmission Loss, dB						Length L, mm
	125	250	500	1k	2k	4k	
CTS 1	14	18	21	29	30	25	900
CTS 2	20	26	35	40	40	40	1800

Width, W 300 to 1200 in increments of 150mm

Depth, D 200, 300 & 400mm

Type: CTL

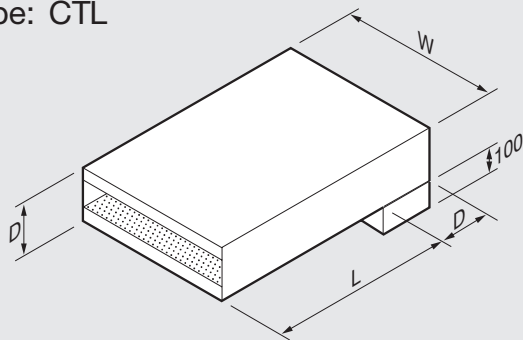

Model Number	Transmission Loss, dB						Length L, mm
	125	250	500	1k	2k	4k	
CTL 1	15	19	23	31	35	30	900
CTL 2	21	27	36	40	40	40	1800

Width, W 300 to 1200 in increments of 150mm

Depth, D 200, 300 & 400mm

Type: CTU

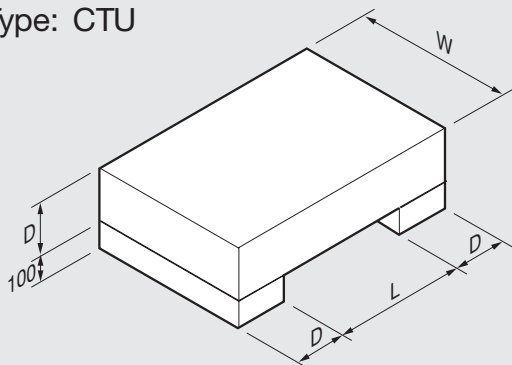

Model Number	Transmission Loss, dB						Length L, mm
	125	250	500	1k	2k	4k	
CTU 1	15	20	24	35	38	35	900
CTU 2	21	28	36	40	40	40	1800

Width, W 300 to 1200 in increments of 150mm

Depth, D 200, 300 & 400mm

Type: CTZ

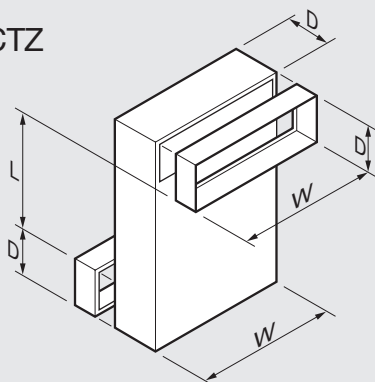

Model Number	Transmission Loss, dB						Length L, mm
	125	250	500	1k	2k	4k	
CTZ 1	15	20	24	35	38	35	900
CTZ 2	21	28	36	40	40	40	1800

Width, W 300 to 1200 in increments of 150mm

Depth, D 200, 300 & 400mm

CROSS-TALK ATTENUATORS

Suggested Specifications

Room to room Cross-Talk attenuators shall be of the Q-Tech CT models and shall have the acoustic performance as scheduled. The Cross-Talk attenuators shall be of a proven design and must have an established history of use. Each unit shall consist of a galvanised sheet metal casing and be provided with internal parallel splitters. The splitter infill shall be a sound absorbing material as specified by the manufacturer. The infill material shall be covered with a gauze scrim to prevent erosion of the fibres then encased in galvanised perforated sheet metal.

The infill material when tested in accordance with AS1530, Part 3, 1989 shall have the following indices:

- Ignitability 0
- Spread of flame 0
- Heat evolved 0
- Smoke developed 0

The contractor shall ensure that an air tight seal is achieved around all wall penetrations to maintain acoustic integrity. Where necessary additional mass lagging shall be applied to the outside of the attenuators to prevent flanking transmission.

All units shall have a constant active acoustic length irrespective of grille or section size. Standard units shall have an active length of 900mm and high performance units an active length of 1800mm.

Acoustic performance specified is quoted as transmission loss as defined in AS1191:1985

Mounting Arrangements

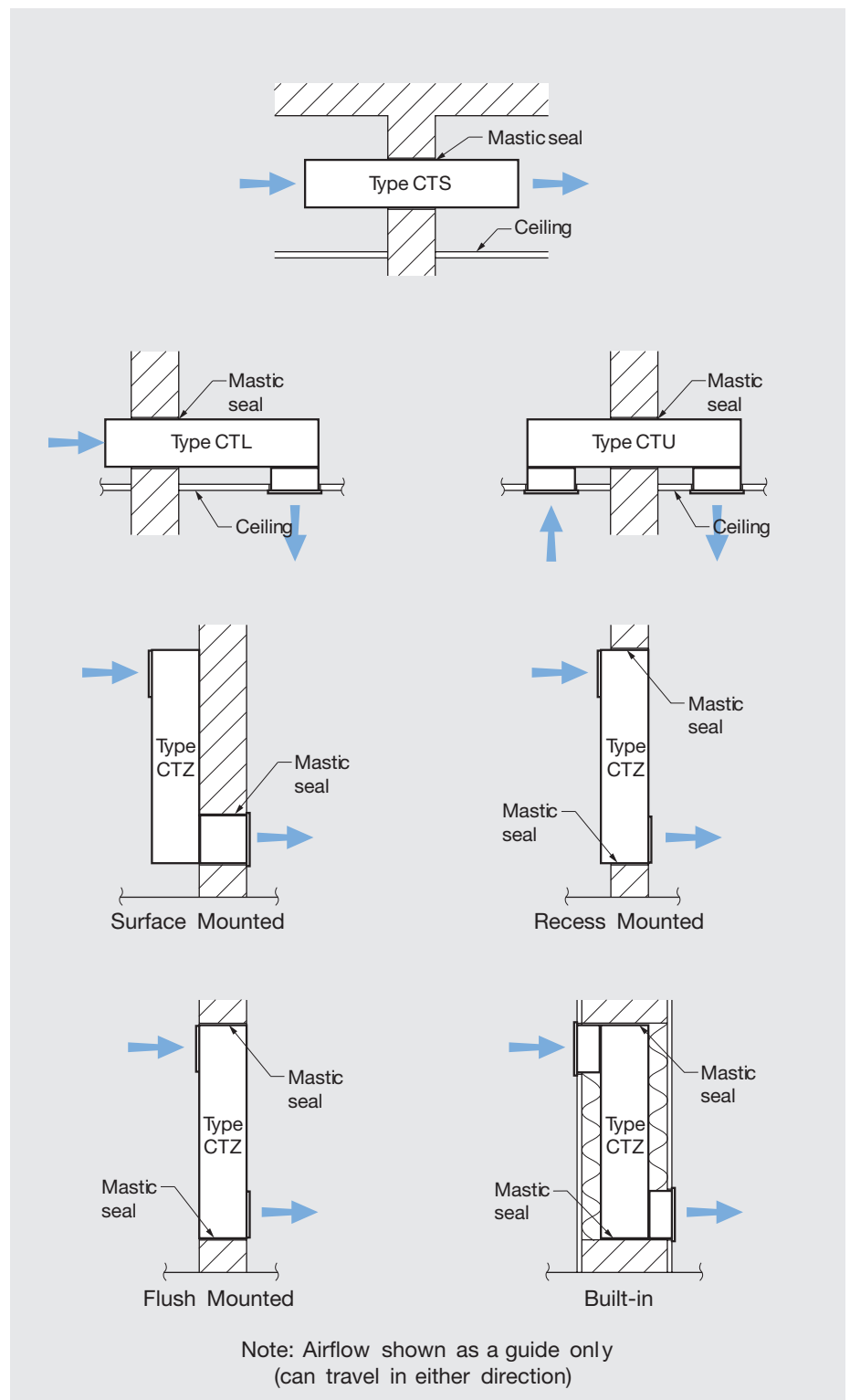

GENERAL ACOUSTIC INFORMATION

Introduction

General

Since 1991, Elta Group Members under the Q-Tech Acoustic Products brand have continuously invested in research and development programs. The investment in this program results in the continuous testing of new designs and materials in our own ISO7235:2003 and BS4718:1971 acoustic attenuator test rig. The results of this program include the first published test data for a range of attenuators based on Australian sourced materials and the advent of the unique Q-Seal range of specialised attenuators. Our continued investments in the research and development of acoustic products results in the most accurate and dependable data for acoustic products, unrivalled by any other supplier in the industry.

Elta Group Members maintain strong relationships with universities, testing houses and the industry to ensure that the experience gained from the use of our products in the real world feeds back into the design of our new products. We will continue to be involved in the latest acoustic technology and innovation and we will continue to provide our customers with products they can rely upon.

The following pages, incorporates a glossary of acoustic terms to assist the user of the Intelligent Ventilation catalogue in understanding the depth of technical information supplied for our fans and attenuators.

Sound Power Level

The sound power is defined as the rate at which a sound source emits energy. Since sound energy in everyday situations ranges from 10^{-12} Watts to 1000 Watts, a logarithmic scale is used for practicality; this provides us with a sound power range from 0 to 150 dB, which is a lot more manageable.

The sound power level is denoted as L_W and is defined as:

and is expressed in decibels, dB

Where:

$$L_W = 10 \log_{10} \frac{(\text{sound power of source, W})}{(\text{reference power, 1pW})}$$

W = Watts and
pW = 10^{-12} Watts

Sound Pressure Level

The sound pressure is what you actually hear and is the effect of the sound power in the hearing environment. It will be a function of the volume of the space, its acoustic absorption qualities and the distance of the listener from the sound source.

Sound pressure level is also expressed in dB and is relative to the quietest sound which a healthy young person can hear at 1kHz; 2×10^{-5} N/m² (or Pa).

The sound pressure level, like sound power is expressed on a logarithmic scale and denoted as L_p . It is defined as:

$$L_p = 20 \log_{10} \frac{(\text{sound pressure, Pa})}{(\text{reference pressure, } 2 \times 10^{-5} \text{ Pa})}$$

Information On Fan Noise Test Standards

Where noted in the product data pages within this catalogue fan noise levels are tested to BS848 Part 2: 1985 "Fans for general purposes. Methods of noise testing".

This test standard describes methods that may be applied to calculate the sound power level of fans. That is, the In-Duct method, the Reverberant Room method and the Free Field method. The sound pressure level of a product is measured using one of these test methods. A calculation is then used to convert the measured sound pressure levels to sound power levels.

GENERAL ACOUSTIC INFORMATION

Attenuator Information

Static Insertion Losses

BS 4718 : 1971 “Methods of Test for Attenuators for Air Distribution Systems” requires manufacturers to test and publish static insertion loss figures.

An insertion loss is defined as “the reduction in noise level at a given location due to the placement of an attenuator in the sound path between the sound source and that location”. A static insertion loss is the insertion loss with no airflow passing through the attenuator.

Therefore placing an attenuator in between a fan and the measuring position, will reduce the noise level at the measuring position by the insertion loss.

Dynamic Insertion Losses

Elta test attenuators to BS4718: 1971 “Methods of Test for Attenuators for Air Distribution Systems”. This test standard sets out a procedure for the testing of static insertion losses; i.e. the measuring of insertion losses without airflow.

Some overseas companies publish dynamic insertion losses; that is the testing of insertion losses with airflow involved. At higher passage velocities the static insertion loss can vary from the dynamic insertion loss by a small margin, depending on the direction of the airflow compared to the noise propagation direction.

For typical velocities associated with a HVAC system, the static insertion losses and dynamic insertion losses are virtually identical and can be assumed to be the same.

Airway Velocity

For a given attenuator size a higher airflow results in a higher airway passage velocity. Higher passage velocities will increase the regenerated noise level of the attenuator. This is particularly critical when the attenuator is serving a low noise level zone; i.e. film studio. A number of suggested maximum passage velocities with the appropriate room NR level are tabulated. Critical noise applications should be checked by an Acoustics Engineer.

		Approx.	
NR25	Do not exceed	8 m/s	In attenuator airway
NR30	“	10 m/s	“
NR35	“	13 m/s	“
NR40	“	15 m/s	“
NR45	“	18 m/s	“

Critical noise level application should be checked by an acoustics engineer

Typical Applications And Benefits Of Attenuator Types

Model	Application	Benefits
Small Circular Type Attenuators		
CC	Bathroom and Toilet exhaust fans	Lightweight
	Tenancy fit outs	Low cost
	Apartment fans	Semi-Flexible
Circular & Rectangular Attenuators		
C./C.P & RT/RS	Car park exhaust fans	Circular: Easy fitting
	Return Air fans	Circular Open: Low pressure drop
	Swimming Pools	Circular Pod: High performance
	Kitchen Exhausts	
	Smoke Spill fans	Rectangular: High performance
Cross-talk Attenuators		
CS/T/ U/Z	Room to room air transfer ducts	
	Police stations	Different designs to suit a wide range of wall/roof configurations
	Office areas	
Sound Bar Acoustic Louvres		
SBL1/2	Plant rooms	Short lengths
ASB		Weatherproof

GENERAL ACOUSTIC INFORMATION

Noise Ratings

dB(A) Levels

The ear responds not only to the absolute sound pressure level of a sound, but also to its frequency content. It actually gives a weighting to the level of sound according to its frequency content, and ascribes a certain loudness. This means that if we want to know how a person will judge the sound, we must somehow translate our objective measured units of sound pressure level and frequency content into subjective units of loudness.

A sound level meter accepts all of the frequency components of a sound, and adds all their absolute levels together to give an overall sound pressure level, dB (Linear).

The illustration below shows typical overall sound pressure levels produced by some everyday sources.

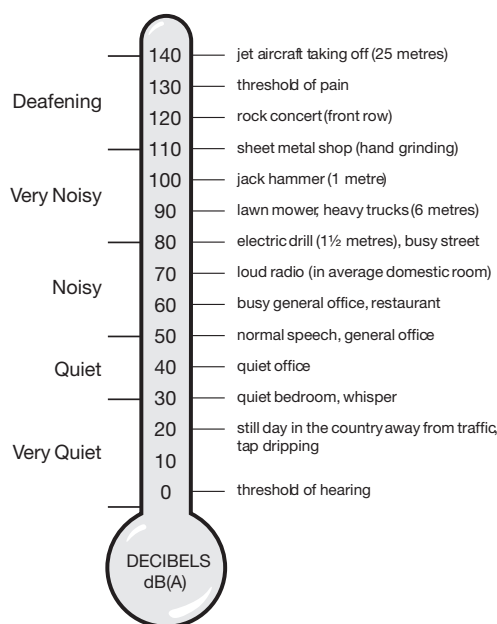

However the ear is not as sensitive to lower frequency sound pressure levels as it is to higher frequency sound pressure levels. In the 1930's, experiments were carried out on 11 people by Harvey Fletcher at the Bell Telephone Laboratories in New York to determine how loud tones of different frequencies sounded subjectively. Therefore the "A" weighting (or the "A" in dB(A)) was devised so that the sound meter would filter each frequency of sound by a certain amount before adding them together to give a loudness that more closely follows the sensitivity of the human ear.

Octave Band Centre Frequency, Hz	63	125	250	500	1000	2000	4000	8000
'A' frequency weighting corrections	-26	-16	-9	-3	0	+1	+1	-1

The 'A' frequency weighting corrections are shown below.

The 'A' frequency weighting suggests that if a tone of 40 dB is played at 1000 Hz, a 40 dB tone played at 63 Hz would sound 26 dB quieter, or be 14 dB(A). Due to its simplicity and convenience, the 'A' frequency weighting has become popular and is now used for many different noise sources at different levels. In fact, most legislation regarding noise is written using dB(A)s, in addition nearly all manufacturers of fans and other noise generating machines quote their noise levels in dB(A)s at 1, 1.5, or 3 metres assuming spherical distribution. It is therefore important that we understand the 'A' frequency weighting and how dB(A)s are calculated.

Calculating dB(A) Levels

Published dB(A), or 'A' frequency weighted, sound pressure levels are theoretical values. These are, in fact, calculated from the sound power level data and are quoted at a specified distance i.e. 1, 1.5, or 3 metres. For example, using the Elta model AP0804AP10/23 (duty 7000 L/s @ 80 Pa, inlet side), by applying an 'A' frequency weighting correction to the fan sound power levels for each frequency and then logarithmically adding the values from left to right the resultant overall sound power level for this unit will be 98 dB(A). A further calculation is required to convert this value from the 'A' weighted sound power level to an 'A' weighted sound pressure level at a prescribed distance from the noise source i.e. 77 dB(A) @ 3m.

GENERAL ACOUSTIC INFORMATION

NR & PNC Ratings

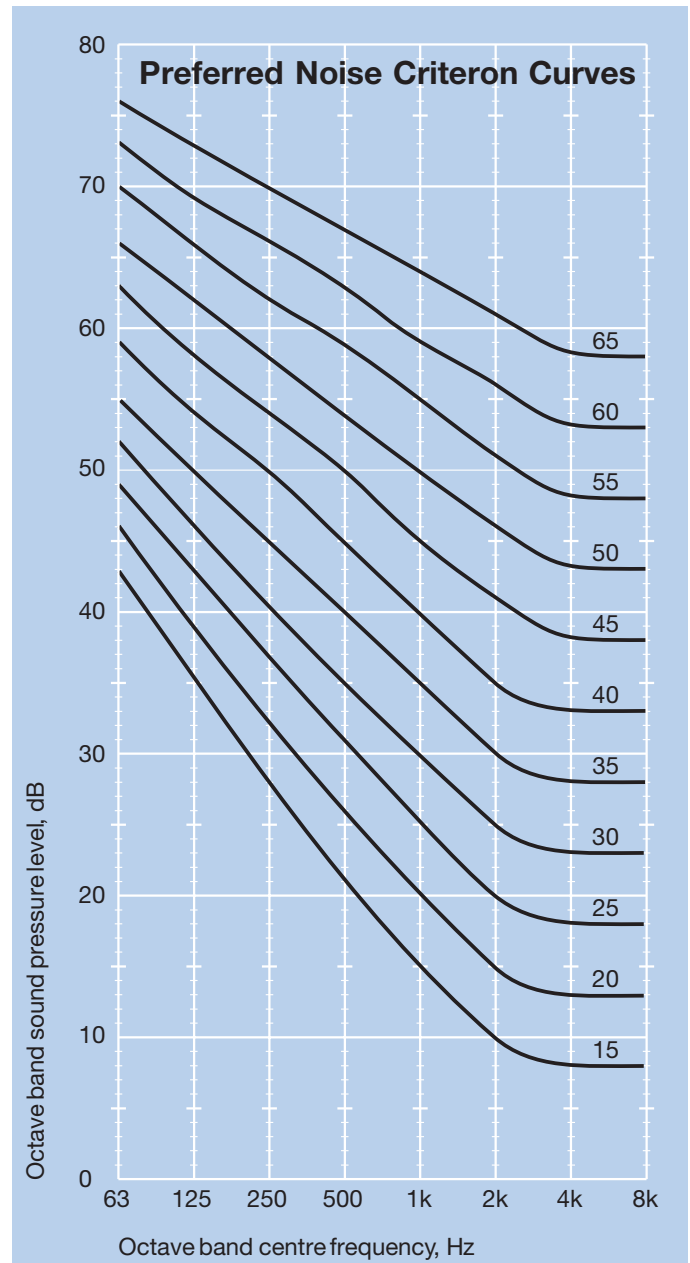
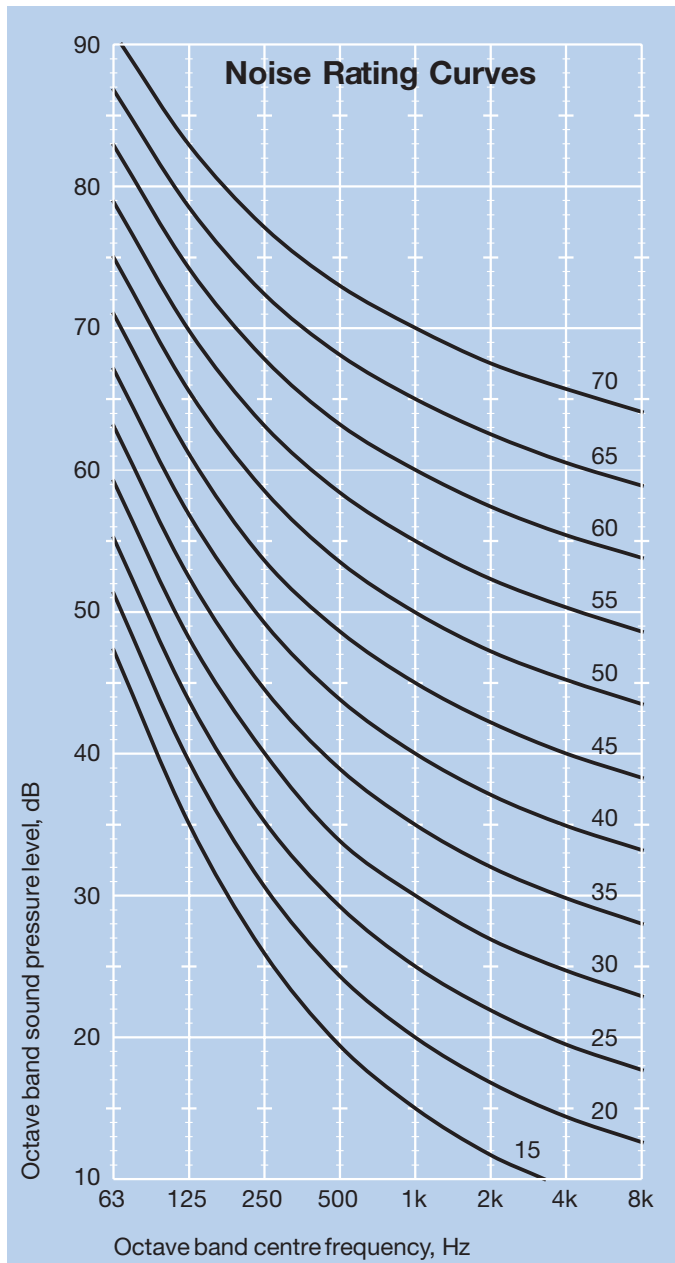

The Noise Rating (or NR contour) curves were proposed by Kosten and Van Os (1962) to rate internal noise levels.

To use the curves, plot the noise spectrum onto the NR curves grid. The Noise Rating is defined as that curve which touches the highest point on the sound pressure spectrum.

Some acoustic consultants prefer to use the Preferred Noise Criterion (PNC) curves. These curves were designed by Beranek (1971) to achieve a more acceptable noise quality and lower the allowable levels of low and high frequency noises.

To use the curves, plot the noise spectrum onto the PNC curves grid. The Preferred Noise Criterion is defined as that curve which touches the highest point on the sound pressure spectrum.

Additional Information

The dB(A) equivalent of the NR values would be approximately 5 dB(A) higher in each instance.

NR and PNC curves are designed to be used with broadband, constant noise sources (eg. motors, engines), and do not allow for the increased annoyance associated with tonal, or pulsating noises.

GENERAL ACOUSTIC INFORMATION

Attenuator Passage Velocity

For industrial applications and to determine attenuator re-generated noise, the passage velocity must be found as described below:

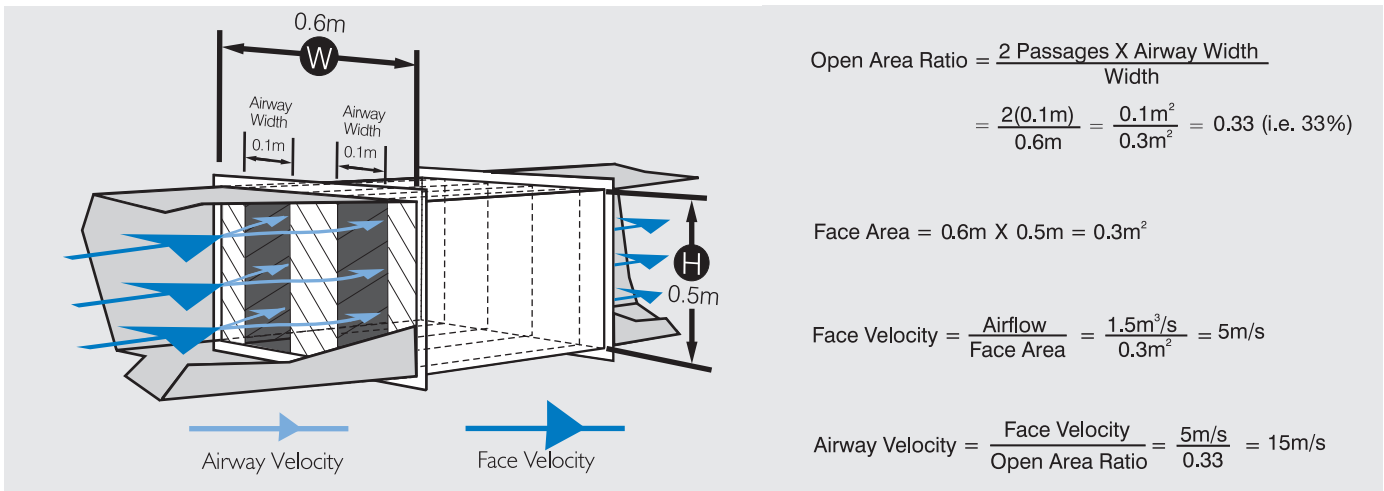

Attenuator Re-Generated/ Airflow Generated Noise :

As air passes through an attenuator it will frequently pass at speeds as much as 2 to 4 times the airflow speed in the duct. Moving air creates noise, so in noise sensitive rooms and installations where attenuators are placed close to air grilles and terminals, particular care must be taken to ensure that this does not become the dominating noise source. The relationship between airway velocity and generated noise is shown below for rectangular attenuators.

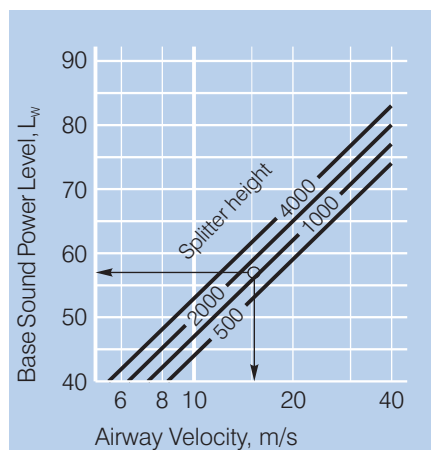

Spectrum Corrections For Airway Velocity:

Airway Velocity m/sec	Octave Band Centre Frequency, Hz							
	63	125	250	500	1k	2k	4k	8k
<8	-2	-6	-7	-10	-12	-16	-19	-22
≥8 & ≤32	-3	-5	-8	-7	-8	-10	-13	-15
>32	-3	-6	-10	-7	-7	-8	-10	-12

GENERAL ACOUSTIC INFORMATION

Reference Information: Acoustic Losses Of Lined Duct & Bends

Table 1: 25mm lined duct

Width (mm)	Height (mm)	Insertion Loss, dB/metre							
		Octave Band Centre Frequency (Hz)							
		63	125	250	500	1k	2k	4k	8k
100	100	6.7	6.8	7.1	11.6	33.1	34.0	15.4	9.0
100	150	5.0	5.4	6.2	10.6	29.2	29.4	14.2	8.6
100	200	4.2	4.7	5.7	10.1	27.1	27.0	13.5	8.4
100	250	3.8	4.4	5.4	9.7	25.9	25.5	13.1	8.3
150	150	3.6	4.1	5.2	9.5	25.0	24.6	12.8	8.2
150	250	2.7	3.2	4.4	8.5	21.4	20.6	11.6	7.8
150	300	2.5	3.0	4.2	8.3	20.5	19.5	11.3	7.7
150	400	2.3	2.7	3.9	7.9	19.3	18.2	10.9	7.6
200	200	2.5	3.0	4.2	8.3	20.5	19.5	11.3	7.7
200	300	2.1	2.4	3.7	7.6	18.1	16.9	10.4	7.4
200	400	2.0	2.2	3.4	7.2	16.8	15.5	9.9	7.3
200	600	1.8	2.0	3.1	6.8	15.5	14.1	9.4	7.1
250	250	2.1	2.4	3.6	7.4	17.6	16.3	10.2	7.4
250	400	1.8	1.9	3.1	6.7	15.2	13.8	9.3	7.0
250	500	1.7	1.8	2.9	6.5	14.4	13.0	9.0	6.9
250	600	1.7	1.7	2.8	6.3	13.9	12.4	8.7	6.8
300	300	1.8	2.0	3.1	6.8	15.5	14.1	9.4	7.1
300	400	1.7	1.8	2.9	6.4	14.1	12.7	8.9	6.9
300	600	1.6	1.6	2.6	5.9	12.7	11.2	8.3	6.6
300	800	1.4	1.5	2.5	5.8	12.1	10.5	8.0	6.6
400	400	1.6	1.6	2.6	5.9	12.7	11.2	8.3	6.6
400	600	1.2	1.3	2.3	5.5	11.3	9.8	7.7	6.4
400	800	1.1	1.2	2.1	5.2	10.5	9.0	7.3	6.3
400	1000	1.0	1.1	2.0	5.0	10.0	8.5	7.1	6.2
500	500	1.2	1.3	2.2	5.4	11.0	9.5	7.5	6.4
500	600	1.1	1.2	2.1	5.2	10.3	8.8	7.2	6.2
500	800	1.0	1.0	1.9	4.8	9.5	8.0	6.9	6.1
500	1000	0.9	0.9	1.8	4.7	9.0	7.5	6.6	6.0
600	600	1.0	1.1	1.9	4.9	9.7	8.2	6.9	6.1
600	800	0.9	0.9	1.7	4.6	8.8	7.3	6.5	5.9
600	1200	0.8	0.8	1.5	4.2	7.9	6.5	6.1	5.7
600	1600	0.7	0.7	1.4	4.1	7.5	6.1	5.8	5.6
800	800	0.8	0.8	1.5	4.2	7.9	6.5	6.1	5.7
800	1000	0.7	0.7	1.4	4.0	7.4	6.0	5.8	5.6
800	1200	0.6	0.6	1.3	3.9	7.0	5.6	5.6	5.5
800	1600	0.6	0.6	1.2	3.7	6.5	5.2	5.3	5.4
1000	1000	0.6	0.6	1.3	3.8	6.8	5.4	5.5	5.5
1000	1200	0.6	0.6	1.2	3.6	6.4	5.1	5.3	5.3
1000	1600	0.5	0.5	1.1	3.4	5.9	4.6	5.0	5.2
1000	2000	0.5	0.5	1.0	3.3	5.5	4.3	4.8	5.1
1200	1200	0.5	0.5	1.1	3.4	6.0	4.7	5.1	5.2
1200	1600	0.5	0.5	1.0	3.2	5.4	4.2	4.8	5.1
1200	2000	0.4	0.4	0.9	3.1	5.1	3.9	4.6	5.0
1200	2400	0.4	0.4	0.9	3.0	4.9	3.7	4.4	4.9

Table 2: 50mm lined duct

Width (mm)	Height (mm)	Insertion Loss, dB/metre							
		Octave Band Centre Frequency (Hz)							
		63	125	250	500	1k	2k	4k	8k
100	100	11.8	12.6	14.8	24.4	33.1	34.0	15.4	9.0
100	150	8.5	9.9	12.8	22.3	29.2	29.4	14.2	8.6
100	200	7.1	8.6	11.7	21.2	27.1	27.0	13.5	8.4
100	250	6.4	7.9	11.1	20.5	25.9	25.5	13.1	8.3
150	150	5.9	7.4	10.7	20.0	25.0	24.6	12.8	8.2
150	250	4.2	5.6	9.0	17.9	21.4	20.6	11.6	7.8
150	300	3.9	5.1	8.5	17.3	20.5	19.5	11.3	7.7
150	400	3.4	4.6	8.0	16.6	19.3	18.2	10.9	7.6
200	200	3.9	5.1	8.5	17.3	20.5	19.5	11.3	7.7
200	300	3.1	4.1	7.4	15.9	18.1	16.9	10.4	7.4
200	400	2.7	3.7	6.8	15.1	16.8	15.5	9.9	7.3
200	600	2.4	3.2	6.2	14.2	15.5	14.1	9.4	7.1
250	250	2.9	3.9	7.2	15.5	17.6	16.3	10.2	7.4
250	400	2.4	3.1	6.1	14.0	15.2	13.8	9.3	7.0
250	500	2.2	2.9	5.7	13.5	14.4	13.0	9.0	6.9
250	600	2.1	2.7	5.5	13.1	13.9	12.4	8.7	6.8
300	300	2.4	3.2	6.2	14.2	15.5	14.1	9.4	7.1
300	400	2.2	2.8	5.6	13.3	14.1	12.7	8.9	6.9
300	600	2.0	2.4	5.0	12.3	12.7	11.2	8.3	6.6
300	800	1.6	2.2	4.8	11.9	12.1	10.5	8.0	6.6
400	400	2.0	2.4	5.0	12.3	12.7	11.2	8.3	6.6
400	600	1.5	2.0	4.4	11.4	11.3	9.8	7.7	6.4
400	800	1.3	1.7	4.0	10.8	10.5	9.0	7.3	6.3
400	1000	1.2	1.6	3.8	10.4	10.0	8.5	7.1	6.2
500	500	1.4	1.9	4.3	11.1	11.0	9.5	7.5	6.4
500	600	1.3	1.7	4.0	10.7	10.3	8.8	7.2	6.2
500	800	1.1	1.5	3.6	10.0	9.5	8.0	6.9	6.1
500	1000	1.0	1.3	3.4	9.6	9.0	7.5	6.6	6.0
600	600	1.1	1.5	3.7	10.2	9.7	8.2	6.9	6.1
600	800	1.0	1.3	3.3	9.5	8.8	7.3	6.5	5.9
600	1200	0.8	1.1	2.9	8.8	7.9	6.5	6.1	5.7
600	1600	0.8	1.0	2.7	8.4	7.5	6.1	5.8	5.6
800	800	0.8	1.1	2.9	8.8	7.9	6.5	6.1	5.7
800	1000	0.8	1.0	2.7	8.3	7.4	6.0	5.8	5.6
800	1200	0.7	0.9	2.5	8.0	7.0	5.6	5.6	5.5
800	1600	0.6	0.8	2.3	7.6	6.5	5.2	5.3	5.4
1000	1000	0.7	0.8	2.4	7.8	6.8	5.4	5.5	5.5
1000	1200	0.6	0.8	2.3	7.5	6.4	5.1	5.3	5.3
1000	1600	0.6	0.7	2.0	7.1	5.9	4.6	5.0	5.2
1000	2000	0.5	0.6	1.9	6.8	5.5	4.3	4.8	5.1
1200	1200	0.6	0.7	2.1	7.2	6.0	4.7	5.1	5.2
1200	1600	0.5	0.6	1.9	6.7	5.4	4.2	4.8	5.1
1200	2000	0.5	0.5	1.7	6.4	5.1	3.9	4.6	5.0
1200	2400	0.4	0.5	1.7	6.2	4.9	3.7	4.4	4.9

Table 3: Square lined bend with turning vanes

d (mm)	Insertion Loss, dB/bend							
	Octave Band Centre Frequency (Hz)							
	63	125	250	500	1k	2k	4k	8k
100	0	0	0	1	4	7	7	7
150	0	0	0	1	4	7	7	7
200	0	0	1	4	7	7	7	7
250	0	0	1	4	7	7	7	7
300	0	0	1	4	7	7	7	7
400	0	1	4	7	7	7	7	7
500	0	1	4	7	7	7	7	7
600	0	1	4	7	7	7	7	7
800	1	4	7	7	7	7	7	7
1000	1	4	7	7	7	7	7	7
1200	1	4	7	7	7	7	7	7
1600	4	7	7	7	7	7	7	7
2000	4	7	7	7	7	7	7	7
2400	4	7	7	7	7	7	7	7

Table 4: Square lined bend without turning vanes

d (mm)	Insertion Loss, dB/bend							
	Octave Band Centre Frequency (Hz)							
	63	125	250	500	1k	2k	4k	8k
100	0	0	0	1	6	11	10	10
150	0	0	0	1	6	11	10	10
200	0	0	1	6	11	10	10	10
250	0	0	1	6	11	10	10	10
300	0	0	1	6	11	10	10	10
400	0	1	6	11	10	10	10	10
500	0	1	6	11	10	10	10	10
600	0	1	6	11	10	10	10	10
800	1	6	11	10	10	10	10	10
1000	1	6	11	10	10	10	10	10
1200	1	6	11	10	10	10	10	10
1600	6	11	10	10	10	10	10	10
2000	6	11	10	10	10	10	10	10
2400	6	11	10	10	10	10	10	10



Elta Asia Sdn Bhd

Tel **+603 7846 0340**

Email **info@elta.asia**

elta.asia

NCP-01-2026 Issue A



FS 676456

A MEMBER OF  ELTA GROUP