

CONTROLLERS, VSD, SENSORS & RUN-ON TIMERS

ELTA

Accessories

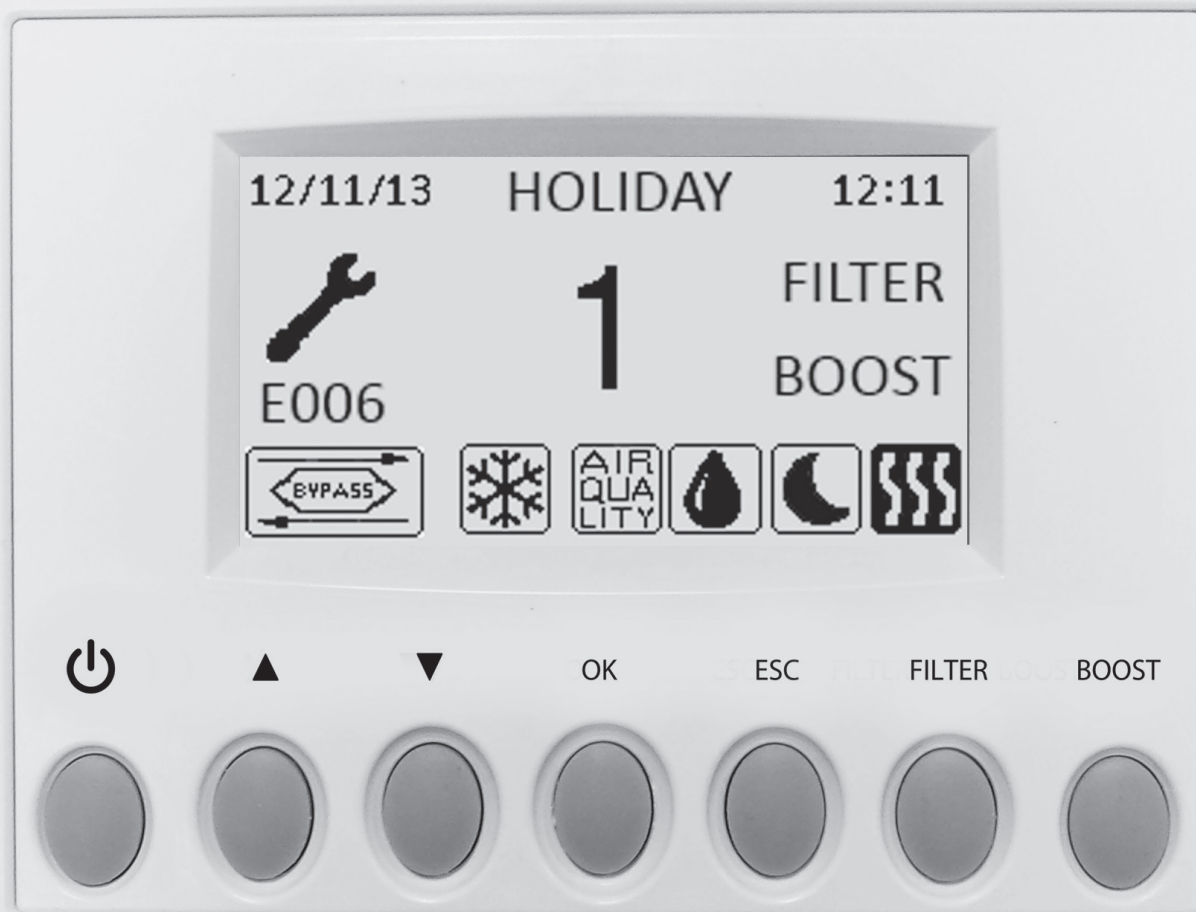

CONTROLLERS, VSD, SENSORS & RUN-ON TIMERS

Introduction

Speed Control

Air capacity control of fans is most efficiently achieved by controlling the fan speed. The principle benefits to be gained are:

- Control of noise
- Control of power absorbed

There are a number of methods that can be used to do this, including:

- Star/delta 2 speed switches
- Triac speed controllers
- Variable speed drives (frequency inverters)
- Multi-speed motors

There are many applications where the full capacity is required for only a short period of time and if no speed control system is available, there is an unnecessary loss of heated or conditioned air or wasted energy taking place. In addition, there are substantial reductions in fan noise and power that can be obtained.

Controlling the speed of a fan by means of changing the supply voltage with a triac speed controller is a simple and often-used method, but it does require certain conditions to be fulfilled:

- The motor must have a high resistance rotor (single phase)
- The motor must have above average cooling

However a triac controller is not an efficient method of speed control.

Additional Information: If more than one fan is to be connected to a single controller, the fans must be identical. Dissimilar fans should not be connected to the same controller and never to multiple multi-speed motors.

When using a speed controller on a single multi-speed single-phase fan, always set or connect fan to "high".

Speed Control Of External Rotor Motors

External rotor motors generally have a high resistance rotor as an inherent feature of their design.

In addition the cooling of these motors is very efficient, so these motors meet the basic requirements necessary for speed control by triac control.

With triac control, heat is generated in the rotor, particularly at around two thirds of full speed. This heat is then transmitted directly to the impeller mounted on the motor and hence into the surrounding air without adding additional thermal stresses on the stator.

Therefore unless otherwise stated, motors operating with a speed-controller should not be run in ambient temperatures exceeding 40°C.

Star/Delta Control

The three-phase external rotor motors fitted to backward-curved centrifugal fans have star/delta motors fitted to them as standard. This facility enables two speeds to be obtained using either a star/delta switch such as the SD1-S or star/delta controller. In addition some axial fans, such as SCD and CPD fitted with conventional motors, have the star/delta feature.

The speed ratio obtained with the star/delta feature is approximately 1.3:1.

CONTROLLERS, VSD, SENSORS & RUN-ON TIMERS

Triac Speed Control

The triac is a type of semi-conductor device and is widely used to speed control single-phase external rotor motors. It functions as a quick-acting switch which turns on the current to the motor during each cycle of the alternating current waveform. The power to the motor can be regulated depending on the point at which the current pulse is received. If the current is switched on early in the cycle, the motor receives maximum voltage and thus full power. The later the current is switched on, the smaller the amount of voltage is released to the motor and thus the power to the motor is lower.

As the voltage waveform supplied to the fan is no longer a sinusoidal shape, magnetic oscillations occur in the fan motor. This is most noticeable at very low speeds. This noise, which is loudest at 100 Hz, may spread throughout the duct system if the motor is not properly vibration-suppressed.

The triac speed controllers are provided with radio interference suppression chokes to reduce the radio interference produced on medium and short-wave bands.

The interference suppression is such that no special precautions have to be taken in normal installations. On premises where there is very sensitive electronic equipment, it may be advisable to use shielded cables and a separate supply or, alternatively, use an auto-transformer control where available.

If more than one fan is connected to a triac-type controller, the amperage of all the fans should not exceed 85% of the maximum rating of the controller. A speed ratio as low as 3:1 is possible.

Variable Speed Drives (Frequency Inverters)

External rotor motors can be speed-controlled using frequency inverters but only if used with all pole effective sinusoidal filters. If using a sinusoidal filter no VSD EMC shielding is needed after the sinusoidal filter.

Speed Control Of Standard Foot And Flange-Mounted Motors

We do not recommend standard motors being controlled by voltage reduction unless they have specially designed high-resistance rotors and suitable cooling systems.

Experience has shown that trying to control the speed of a conventional motor by voltage reduction is seldom satisfactory. On a standard motor, all changes in speed when using a voltage reducing device, occur over a very narrow band of voltage and it is therefore hard to achieve an acceptable accuracy of adjustment. In addition, due to the level of heat generated, there is a risk of damage to the windings and bearings.

Some motors with these features are available on request.

Variable Speed Drives (Frequency Inverters)

Standard three-phase motors can be speed-controlled satisfactorily using frequency inverters which vary both the frequency and voltage of the electricity supply to the motor.

This system provides infinite variation of the fan speed, but the motors may become noisy because the dynamics of the mechanical system may cause resonances or the electrical noise may no longer be masked by the reduced air noise.

Shielded cable is normally required with frequency inverters.

Electro-Magnetic Compatibility (EMC) Compliance

These speed controllers normally require the electrical cables between the inverter and fan motor to be shielded along their entire length to comply with regulations. Inform our Sales Engineers if an Inverter is going to be used so it can be ensured that all fan internal wiring is shielded to meet EMC requirements.

Additional care must be taken if the inverter unit is mounted remotely from the fan being controlled.

CONTROLLERS, VSD, SENSORS & RUN-ON TIMERS

Multi-Speed Motors

These can be either tap (Dahlander) or dual-wound.

Tap-wound motors use a single set of windings with a control 'tap' in each coil.

The speed ratio is 2:1 and the maximum speed can be any synchronous speed. i.e 48, 24, 16, 12, rev/sec etc.

Dual-wound motors are effectively two motors in one as there are two separate sets of windings in the one motor frame. With dual-wound motors almost any combination of standard motor speeds is possible.

Multi-speed motors provide excellent power saving and the noise reduction is the same as any other fan with the same speed difference.

The air capacities available are directly proportional to the speeds.

Although by no means exclusive the above methods are more frequently applied to standard motors.

Additional Information: Multi-speed motors are typically larger than their single speed equivalents.

General

If you have requirements not detailed here, contact our Sales Engineers for assistance, as not all control devices have been covered in this catalogue.

Summary Of Air Capacity Control Options

Control Type	Speed Ratio	Approx. Power Savings	Relative Cost
Star/delta switch	1.3:1	50%	low
Star/delta controller	1.3:1	50%	moderate
Triac	10:1	to 70%	low
Capacitance	Down to 2:1	varies	low/moderate
Frequency inverter	5:1	to 90%	highest
Tap winding	2:1	87%	low/moderate
Dual-wound	3:2	70%	low/moderate

CONTROLLERS, VSD, SENSORS & RUN-ON TIMERS

SPEED CONTROLLER WITH ON/OFF SWITCH



Technical Data

Model Number	Input Power	Mount Type	Dimensions, mm (W x H x D)
CTRL-M	230V~ 50-60 Hz.	Wall	78 x 78 x 19.8

Description

The potentiometer, also known as a speed controller, is suitable for use with most EC brushless motors. It features a front knob to adjust the motor speed of the fan and a two-pole ON/OFF switch. Front yellow LED standby light indicates that the load is active. Controller can be surface or recess mounted.

3-SPEED CONTROLLER FOR HEAT RECOVERY UNITS



Technical Data

Model Number	Input Power	Mount Type	Dimensions, mm (W x H x D)
CTRL-S	230V~ 50-60 Hz.	Wall	78 x 78 x 19.8

Description

The controller is used specifically with heat recovery units. It features three simple to use switches to select speed settings. The user can also select either heat exchange or free-cooling mode for added comfort. Controller can be surface or recess mounted.

3-SPEED CONTROLLER



Technical Data

Model Number	Input Power	Mount Type	Dimensions, mm (W x H x D)
SEL-3V	230V~ 50-60 Hz.	Wall	78 x 78 x 19.8

Description

The speed controller features a simple to use large front selection knob. This gives the user a choice of three preset speeds and includes an additional OFF position. The clean and modern looking controller can be surface or recess mounted. Max load 3A.

SPEED CONTROLLER WITH ON/OFF SWITCH



Technical Data

Model Number	Input Power	Mount Type	Dimensions, mm (W x H x D)
REL-1A	230V~ 50-60 Hz.	Wall	78 x 78 x 19.8

Description

The electric controller features a front knob to adjust the motor speed of the fan and an ON/OFF push switch. Front yellow LED standby light indicates that the load is active. Controller can be surface or recess mounted. Max load 1A.

SPEED CONTROLLERS SINGLE-PHASE MOTORS

TYPE - VA



Technical Data

Model Number	Max. Amps	On/Off Switch	Mounting	LED Power Light	Dimensions, mm
VA2.0POT**	2.0	No	Bracket	No	25W x 30H x 50D
VA2.0	2.0	Yes	Recess	No	70W x 114H x 36D
VA2.8	2.8	Yes	Recess	Yes	70W x 114H x 36D
VA5.0	5.0	Yes	Recess	No	70W x 114H x 51D
VA8.0	8.0	Yes	Recess	Yes	70W x 114H x 51D

Enclosure rating - IP00

** The VA2.0POT unit is designed to be mounted within equipment or enclosures; e.g. HB12E Fan Header Boxes, as well as Mixvent Series duct mounted fans. It will not fit in a standard wall plate.

The VA range, being triac-type controllers, can cause an electronic hum particularly at low speeds.

The VA range is generally suitable for use with any speed-controllable single-phase motors. Ensure the motor amperage does not exceed the rating of the controller.

Description

The VA range is an electronic type speed-controller which provides infinite variation of fan speed from 100% down to approximately 30% of full speed.

When used to control a number of identical fans the sum of the full load amps of all the connected fans must not exceed 85% of the maximum rating of the controller. The fans should be identical.

Power consumption is reduced by up to 70%.

The motors must be designed for speed control.

Warning

Check with our Sales Department before using the VA controllers with run-on timers.

Additional Information

To minimise electronic hum from larger PSC (Permanent Split Capacitor) motors, a constant active is connected to the start winding via the capacitor and the run winding is regulated by the speed controller. (4 wire connection)

A PSC motor is sometimes referred to as a Capacitor Run motor.

Wiring Diagrams

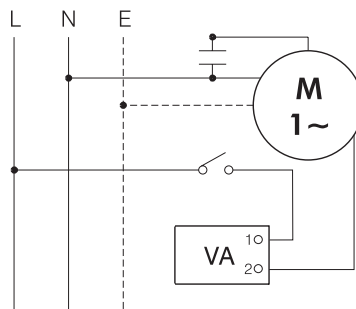

VA2.0POT

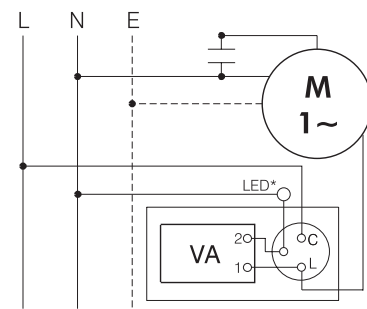

VA2.0 & VA2.8
for 3 wire connection

* LED on VA2.8 only

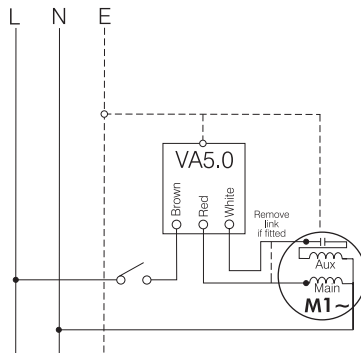

VA5.0

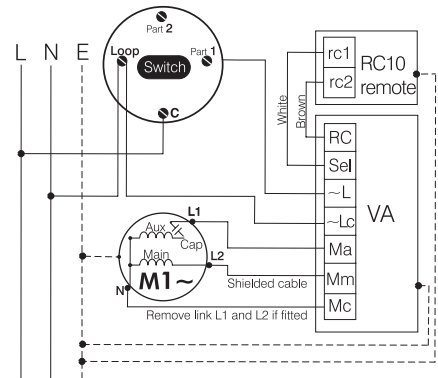

VA8.0

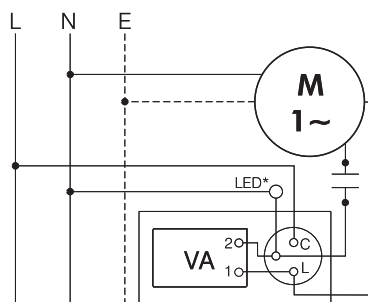

VA2.0 & VA2.8
for 4 wire connection

SPEED CONTROLLERS SINGLE-PHASE MOTORS

TYPE - VA-PL

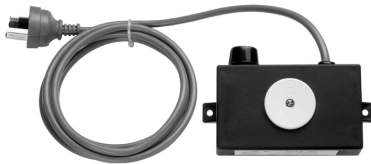

Description

The VA2.0-3PL is designed to speed control single-phase fans fitted with a 3-pin plug. The VA2.0-3PL has a 900mm lead and 3-pin plug for connection to a 3-pin GPO.

TYPE - AVA3.0

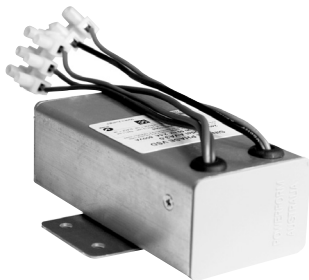

Description

The AVA3.0 controller will vary the speed of 240V AC single phase fan motors in response to DC input signals such as 2 to 20 milliamps or 0 to 10 volts. A potentiometer may be used in lieu of input signals to provide manual control when in 0-10V control. A model that includes an IP55 rated enclosure is available.

Technical Data

Model Number	Max. Amps	Enclosure Size, mm
VA2.0-3PL	2.0	110W x 66H x 36D

Technical Data

Model Number	Max. Amps	Enclosure Size, mm
AVA3.0	3.0	110W x 40H x 50D
AVA3.0-IP55	3.0	165W x142H x 84D

The AVA3.0 is a stepless speed controller for single phase AC external rotor motors. Rated at 240V, 3 Amp, suitable for 50/60 Hz 600VA up to 55°C.

Wiring Diagram

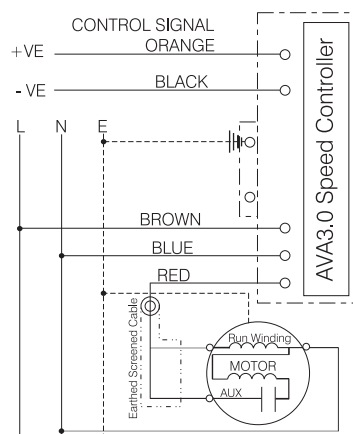

Additional Information:

Wiring may differ depending on the motor controlled and the input device. Always consult the product wiring instructions.

0-10V or 2-20mA is selected via an internal jumper.

TYPES - AVA5.0 & AVA8.0



Description

The AVA5.0 and AVA8.0 controllers will vary the speed of 240V AC single phase fan motors in response to DC input signals such as 2 to 20 milliamps or 0 to 10 volts. A potentiometer may be used in lieu of input signals to provide manual control when in 0 to 10V control.

Technical Data

Model Number	Max. Amps	Enclosure Size, mm
AVA5.0	5.0	174W x 114H x 74D
AVA8.0	8.0	174W x 114H x 74D

The AVA5.0 and AVA8.0 are stepless speed controllers for single phase AC external rotor motors.

The AVA5.0 is rated at 240V, 5 Amp and suitable for 50/60 Hz 1200VA up to 35°C.

The AVA8.0 is rated at 240V, 8 Amp and suitable for 50/60 Hz 2000VA up to 35°C.

Wiring Diagram

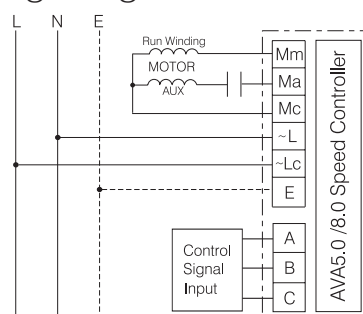

Additional Information:

Wiring may differ depending on the motor controlled and the input device. Always consult the product wiring instructions.

0-10V or 2.20mA is selected via an internal jumper.

SPEED CONTROLLERS THREE-PHASE MOTORS

TYPE - SD1-S



Technical Data

Model Number	Max. Amps	Mounting	Enclosure Size, mm
SD1-S	20	Recess	114W x 70H x 90D

The unit incorporates an ON-OFF switch with high and low speed settings.

Description

The SD1-S unit is a star/delta switch designed for use with three-phase star/delta motors. Speed change is approximately in the ratio of 1.3:1 and the power saving is up to 50%.

The SD1-S switch is suitable for the entire range of three-phase two speed star/delta external rotor motors used on the backward-curved centrifugal fan products supplied by Elta. In addition it can be used with a range of two speed star/delta motors fitted to axial flow fans.

The unit is a simple switch and does not provide any protection to the motor. As defined in the wiring code AS/NZS3000:2000, three-phase motors that are unattended must be suitably protected; HRC fuses are not sufficient for that purpose.

Wiring Diagram

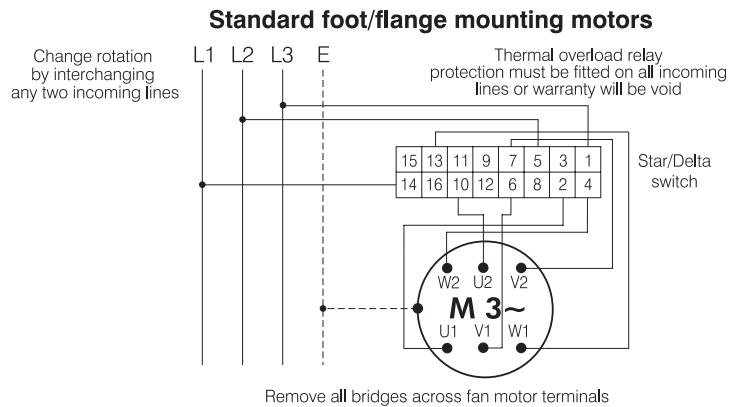

Rosenberg & Ziehl External Rotor Motors

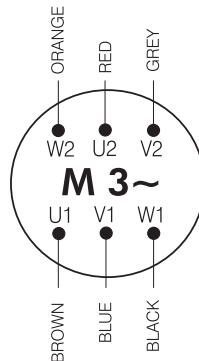

EBM External Rotor Motors

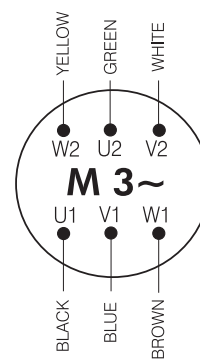

Different centrifugal external rotor motors fans can have different coloured leads as shown

VARIABLE SPEED DRIVES (VSD)

VACON NXL VARIABLE SPEED DRIVE



Description

The Vacon NXL is a powerful and compact AC drive that is suitable for building services applications and most light industrial purposes. It features versatile programming capabilities that offer optimal solutions for most operating environments.

Features

- User friendly interface with start-up wizard for quick and easy configuration.
- Built-in EMC/RFI filter to remove electromagnetic interference and lower harmonic levels.
- Easy to configure Inputs/Outputs with RS485 integration and expansion slots.
- Includes AC choke and brake chopper to balance voltage drops and spikes.
- Integrated PID controller provides smooth variable speed control.

Standard I/O

- 3 x Digital input
- 2 x Analogue input
- 1 x Digital output
- 2 x Analogue output
- 3 x Relay output

Testing

Harmonics Standard IEC 61800-3-12
EMC Standard EN61800-3 Category C2

Wiring Diagram

Please refer enquires to Elta sales engineers.

Technical Data

Model Number	Input/Output	Motor, kW @ 40°C	Amps @ 40°C	Frame Size	Protection Class	Dimensions, mm	Weight, kg.		
NXL00035	3 phase/ 3 phase	1.1	3.3	MF4	IP54	128W x 292H x 190D	5.0		
NXL00045		1.5	4.3						
NXL00055		2.2	5.6						
NXL00075		3.0	7.6						
NXL00095		4.0	9.0	MF5		144W x 391H x 214D	8.1		
NXL00125		5.5	12.0						
NXL00165		7.5	16.0						
NXL00235		11.0	23.0	MF6				195W x 519H x 237D	18.5
NXL00315		15.0	31.0						
NXL00385		18.5	38.0						
NXL00465		22.0	46.0						
NXL00615		30.0	61.0						

VARIABLE SPEED DRIVES (VSD)

VACON 10 VARIABLE SPEED DRIVE



Description

The Vacon 10 variable speed drive has been designed for applications where simplicity and efficiency are key requirements. The compact size of the enclosure with forced cooled heat sink allows the drive to be installed into confined spaces.

Features

- User friendly interface with start-up wizard for quick and easy configuration.
- EMC filter to remove electromagnetic interference and lower harmonic levels.
- Forced cooled heat sink is mounted directly onto the power semiconductors.
- Integrated PID controller provides smooth variable speed control
- Built-in RS485 interface for fieldbus control.

Standard I/O

- 6 x Digital input
- 1 x Analogue input
- 1 x Digital output
- 1 x Analogue output
- 2 x Relay output

Testing

EMC Standard EN61800-3 Category C2

Wiring Diagram

Please refer enquires to Elta sales engineers.

Technical Data

Model Number	Input/Output	Motor, kW @ 40°C	Amps @ 40°C	Frame Size	Protection Class	Dimensions, mm	Weight, kg.
V00101L00012		0.25	1.7				
V00101L00022		0.37	2.4	MI1		66W x 160H x 99D	0.55
V00101L00032		0.55	2.8				
V00101L00042	1 phase/ 3 phase	0.75	3.7				
V00101L00052		1.10	4.8	MI2		90W x 195H x 102D	0.70
V00101L00072		1.50	7.0				
V00101L00092		2.20	9.6	MI3		100W x 252H x 109D	0.99
V00103L00014		0.37	1.3				
V00103L00024		0.55	1.9	MI1	IP20	66W x 160H x 99D	0.55
V00103L00034		0.75	2.4				
V00103L00044		1.10	3.3				
V00103L00054	3 phase / 3 phase	1.50	4.3	MI2		90W x 195H x 102D	0.70
V00103L00064		2.20	5.6				
V00103L00084		3.00	7.6				
V00103L00094		4.00	9.0	MI3		100W x 252H x 109D	0.99
V00103L00124		5.50	12.0				

VARIABLE SPEED DRIVES (VSD)

VACON 20 VARIABLE SPEED DRIVE



Description

The Vacon 20 is a compact AC drive that features a wide power range from 0,25 kW to 18,5 kW. The built-in PLC allows programmable logic to be easily altered which enables unused input/outputs of the drive to be assigned to other tasks.

Features

- Basic interface with start-up wizard for quick and easy configuration.
- Built-in EMC filter to remove electromagnetic interference and lower harmonic levels.
- Built-in RS485 interface for fieldbus control.
- AC choke and brake chopper to balance voltage drops and spikes.
- HVAC software available.
- HVAC fire mode with quick start wizard available.

Standard I/O

- 6 x Digital input
- 2 x Analogue input
- 1 X Digital output
- 1 x Analogue output
- 2 x Relay output

Testing

EMC Standard EN61800-3 Category C2

Wiring Diagram

Please refer all enquires to Elta sales engineers.

Technical Data

Model Number	Voltage	Input/Output	Motor kW @ 40°C	Amps @ 40°C	Frame Size	Class Protection	Dimensions, mm	Weight, kg.
V00201L00012	208-240VAC	1 phase/ 3 phase	0.25	1.7	MI1	IP20	66W x 160H x 190D	0.55
V00201L00022			0.37	2.4				
V00201L00032			0.55	2.8				
V00201L00042			0.75	3.7	MI2			
V00201L00052			1.1	4.8				
V00201L00072			1.5	7				
V00201L00092			2.2	9.6	MI3		100W x 255H x 109D	0.99
V00203L00014	380-480VAC	3 phase/ 3 phase	0.37	1.3	MI1	IP21	66W x 160H x 99D	0.55
V00203L00024			0.55	1.9				
V00203L00034			0.75	2.4				
V00203L00044			1.1	3.3	MI2			
V00203L00054			1.5	4.3				
V00203L00064			2.2	5.6				
V00203L00084			3	7.6	MI3			
V00203L00094			4	9				
V00203L00124			5.5	12				
V00203L00164			7.5	16	MI4			
V00203L00234			11	23				
V00203L00314			15	31				
V00203L00384	18.5	38	MI5		165W x 414H x 202D	10.00		

VARIABLE SPEED DRIVES (VSD)

VACON 20X VARIABLE SPEED DRIVE



Description

The Vacon 20X variable speed drive with IP66 enclosure provides the best possible protection in exposed conditions. It offers a decentralised solution with mains switch option and large cooling ribs for effective heat dissipation.

Features

- User friendly interface with start-up wizard for quick and easy configuration.
- Built-in EMC filter to remove electromagnetic interference and lower harmonic levels.
- AC choke and brake chopper to balance voltage drops and spikes.

- Integrated PID controller provides smoother variable speed control.
- Built-in RS485 interface for fieldbus control.
- Safe Torque Off (STO) mode.
- IP66 dust and weather protected enclosure.
- Capable of withstanding 2G resistance to vibrations.
- Can be used in limited adverse/corrosive environments. (For more information refer to Elta)
- HVAC software available.
- HVAC fire mode with quick start wizard available.

Standard I/O

- 6 x Digital input
- 2 x Analogue input
- 1 X Digital output
- 1 x Analogue output
- 2 x Relay output

Testing

EMC Standard EN61800-3 Category C2
2G resistance to vibrations (according to 3M6/IEC 60068-2)

Wiring Diagram

Please refer all enquires to Elta sales engineers.

Technical Data

Model Number	Mains Switch	Voltage	Input/ Output	Motor kW @ 40°C	Amps @ 40°C	Frame Size	Class Protection	Dimensions, mm	Weight kg.
V00203L00034X				0.75	2.4				
V00203L00044X				1.1	3.3				
V00203L00054X				1.5	4.3	MU2		170W x 295H x 174D	3.4
V00203L00064X				2.2	5.6				
V00203L00084X				3.0	7.6				
V00203L00094X				4.0	9.0				
V00203L00124X				5.5	12.0	MU3		206W x 376H x 203D	6.0
V00203L00164X		380-480 VAC	3 phase/ 3 phase	7.5	16.0		IP66		
V00203L00034XMS				0.75	2.4				
V00203L00044XMS				1.1	3.3				
V00203L00054XMS				1.5	4.3	MU2		170W x 295H x 174D	3.4
V00203L00064XMS				2.2	5.6				
V00203L00084XMS				3.0	7.6				
V00203L00094XMS				4.0	9.0				
V00203L00124XMS				5.5	12.0	MU3		206W x 376H x 203D	6.0
V00203L00164XMS				7.5	16.0				

VARIABLE SPEED DRIVES (VSD)

VACON 100 HVAC VARIABLE SPEED DRIVE



Description

The Vacon 100 HVAC is a dedicated drive designed to work with heating, ventilation and air conditioning systems. This drive is easy to install and features a trouble-free set up which ensures it is fast and efficient to commission.

It incorporates thin film capacitors which help to maintain a smaller drive size and eliminate shelf or standby issues. The Vacon 100 also saves significant energy through cooling fan speed reduction. The drive control features soft start and real time clock functions.

Features

- User friendly interface with start-up wizard for quick and easy configuration.
- Built-in EMC filter to remove electromagnetic interference and lower harmonic levels.
- Modbus RTU, Metasys N2 and BACnet via RS485 is standard.
- BACnet IP and Modbus TCP via Ethernet is standard.
- Integrated 2 x PID controllers provide smooth variable speed control.
- HVAC fire mode with quick start wizard is standard.
- Real time clock with optional battery backup.
- DC choke is standard.

Testing

Harmonics Standard IEC 61800-3-12
EMC Standard EN61800-3 Category C2

Wiring Diagram

Please refer all enquires to Elta sales engineers.

Technical Data

Model	Input/Output	Motor kW @ 40°C	Amps @ 40°C	Frame Size	Protection Class	Dimensions, mm	Weight, kg.
V01003L00035H		1.1	3.4				
V01003L00045H		1.5	4.8				
V01003L00055H		2.2	5.6	MR4		128W x 328H x 190D	6.0
V01003L00085H		3.0	8.0				
V01003L00095H		4.0	9.6				
V01003L00125H		5.5	12.0				
V01003L00165H		7.5	16.0				
V01003L00235H		11.0	23.0	MR5		144W x 419H x 214D	10.0
V01003L00315H		15.0	31.0				
V01003L00385H	3 phase/ 3 phase	18.5	38.0	MR6	IP54	195W x 557H x 229D	20.0
V01003L00465H		22.0	46.0				
V01003L00615H		30.0	61.0				
V01003L00725H		37.0	72.0				
V01003L00875H		45.0	87.0	MR7		237W x 660H x 259D	37.5
V01003L01055H		55.0	105.0				
V01003L01405H		75.0	140.0				
V01003L01705H		90.0	170.0	MR8		290W x 966H x 343D	70.0
V01003L02055H		110.0	205.0				
V01003L02615H		132.0	261.0	MR9		480W x 1150H x 365D	108.0
V01003L03105H		160.0	310.0				

VARIABLE SPEED DRIVES (VSD)

VACON 100X VARIABLE SPEED DRIVE



- Built-in EMC filter to remove electromagnetic interference and lower harmonic levels
- Supports both induction and permanent magnet motors
- Integrated RS485 Modbus and Ethernet communication for BacNet IP and Modbus TCP/IP
- Safe Torque Off (STO) mode
- DC choke and thin film capacitors
- IP66 dust and weather protected enclosure
- Suitable for ambient temperatures up to 60°C
- Capable of withstanding 3G resistance to vibrations
- Can be used in limited adverse/corrosive environments. (For more information refer to Elta)
- HVAC software available
- HVAC fire mode with quick start wizard available.

Description

The Vacon 100X sets a new benchmark for decentralized drive solutions. It is ideal for external mounting as it features a die-cast metal enclosure that provides an IP66 class protection rating. The breathable Gore-Tex® vent helps protect the drive's seals and heat sink, and incorporates a speed controlled fan that effectively dissipates heat.

Features

- User friendly interface with start-up wizard for quick and easy configuration

Standard I/O

- 6 x Digital input
- 2 x Analogue input
- 1 x Analogue output
- 2 x Relay output

Testing

Harmonics Standard IEC 61800-3-12
EMC Standard EN61800-3 Category C2
3G resistance to vibrations (according to 3M7/IEC 60068-2)

Wiring Diagram

Please refer all enquires to Elta sales engineers.

Technical Data

Model	Input/Output	Motor kW @ 40°C	Amps @ 40°C	Frame Size	Protection Class	Dimensions, mm	Weight, kg.
V01003L00034X		1.1	3.4				
V01003L00044X		1.5	4.8				
V01003L00054X		2.2	5.6				
V01003L00084X		3.0	8.0	MM4		191W x 316H x 214D	8.8
V01003L00094X		4.0	9.6				
V01003L00124X		5.5	12.0				
V01003L00164X	3 phase/ 3 phase	7.5	16.0		IP66		
V01003L00234X		11.0	23.0	MM5		233W x 367H x 231D	14.9
V01003L00314X		15.0	31.0				
V01003L00384X		18.5	38.0				
V01003L00464X		22.0	46.0				
V01003L00614X		30.0	61.0	MM6		350W x 500H x 255D	31.5
V01003L00724X		37.0	72.0				

RUN-ON TIMERS

DIRECT WIRED TYPE - VZ



Description

The VZ run-on timer is designed to permit the supply of electricity to motors so they can continue to operate for a predetermined time.

They are designed to be mounted within equipment or enclosures.

Approval Number Q051613

They can be used with single or three-phase motors.

Warning

Check with our sales department before using a run-on timer with a VA controller. Not to be used with fans with EC motors or inverters.

Technical Data

Model Number	Run-On Time	Start Delay	Max. Amps	Dimensions, mm
VZ24C	Up to 24 min*	Up to 150 sec		
VZ6	6 min	50 sec	1.25**	32W x 13H x 17D
VZ12	12 min	50 sec		

Enclosure rating - IP40

* 1.5 min increments

**Minimum amps: 0.075

Wiring Diagram

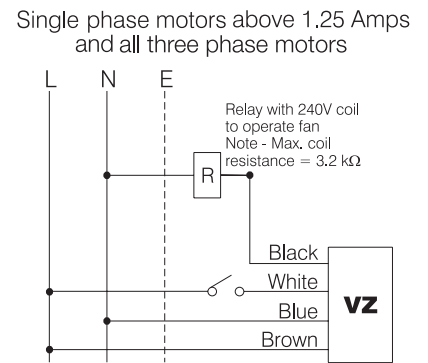
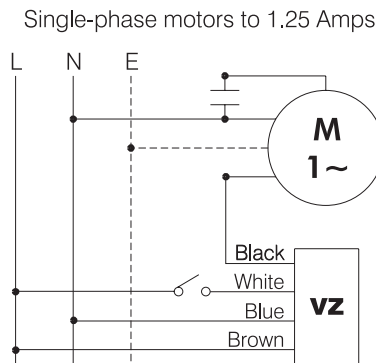

DIRECT WIRED SUPPLY WITH PLUG-IN OUTLET SINGLE SWITCH INPUT TYPE - VZ-TS



Description

The VZ2-10TS plug-in run-on timer is designed to permit the supply of electricity to motors so they can continue to operate for a predetermined time.

This unit is designed for single-phase fans with a 3-pin plug fitted. The mains connection is wired directly into the terminals of the run-on timer; **no 4-pin outlet is required.**

Run-on time is adjustable from 2-10 minutes.

Warning

Not to be used with fans with EC motors or inverters.

Technical Data

Model Number	Run-On Time	Start Delay	Max. Amps	Enclosure Size, mm
VZ2-10TS	2-10 min	n/a	5	153W x 110H x 60D

Suggested Wiring Arrangement

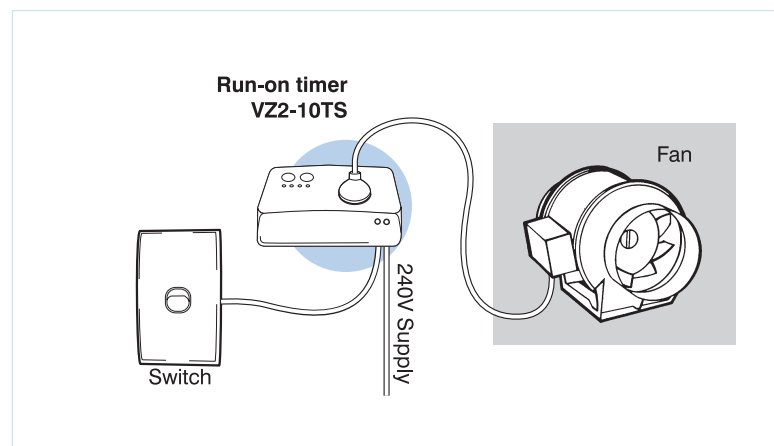

RUN-ON TIMERS

DIRECT WIRED SUPPLY WITH PLUG-IN OUTLET MULTI-SWITCH INPUT TYPE - VZM



Description

The VZM0-28TS plug-in run-on timer is designed to permit the supply of electricity to motors so they can continue to operate for a predetermined time.

This unit is designed for multiple switch inputs to operate a single-phase fan with a 3-pin plug. The mains supply connection is wired directly into the terminals of the run-on timer. **No 4 pin outlet is required.**

Run-on time is adjustable from 0-30 min with a start delay of 0-5 min.

Can be used with VZ-INSE switch.

Warning

Not to be used with fans with EC motors or inverters.

Technical Data

Model Number	Run-On Time	Start Delay	Max. Amps	Enclosure Size, mm
VZM0-28TS	0-30 min	0-5 min	5	153W x 110H x 60D

Suggested Wiring Arrangement

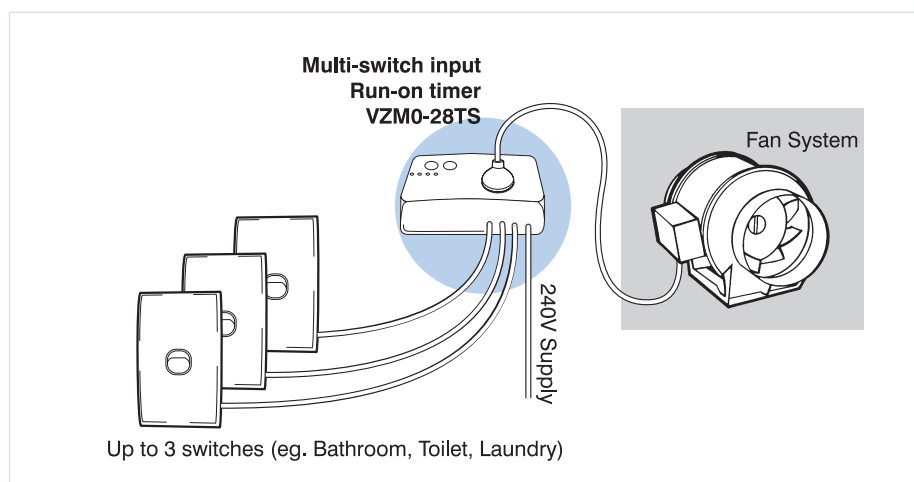

4-PIN PLUG SUPPLY WITH PLUG-IN OUTLET TYPE - VZ-PL



Description

The VZ6-4PL plug-in run-on timer is designed to permit the supply of electricity to motors so they can continue to operate for a predetermined time.

This unit is designed for single-phase fans fitted with a 3-pin plug. The VZ6-4PL has a 900mm lead and 4-pin plug for connection to a 4-pin outlet.

Run-on time is fixed at 6 minutes.

Warning

Not to be used with fans with EC motors or inverters.

Technical Data

Model Number	Run-On Time	Start Delay	Max. Amps	Enclosure Size, mm
VZ6-4PL	6 min	n/a	5	153W x 110H x 60D

Suggested Wiring Arrangement

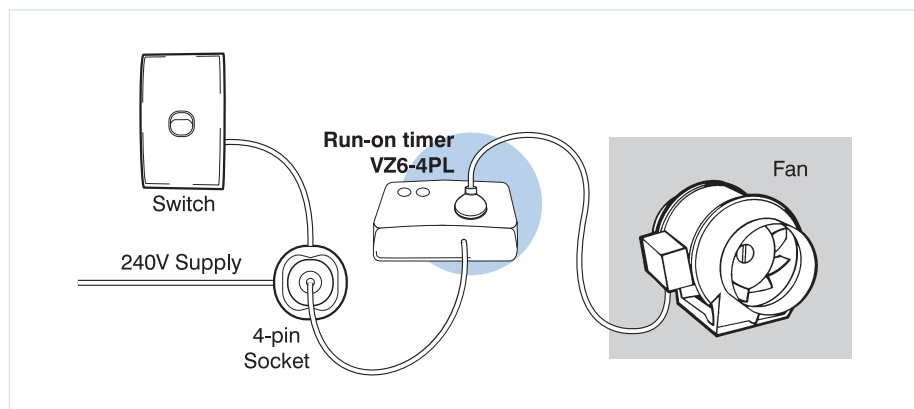

RUN-ON TIMERS

4-PIN PLUG SUPPLY WITH PLUG-IN OUTLET FITTED WITH SPEED CONTROLLER TYPE - VA-VZ



Technical Data

Model Number	Run-On Time	Start Delay	Max. Amps	Enclosure Size, mm
VA2.0/VZ6-4PL	6 min	50 sec	1.25	110W x 66H x 36D

Suggested Wiring Arrangement

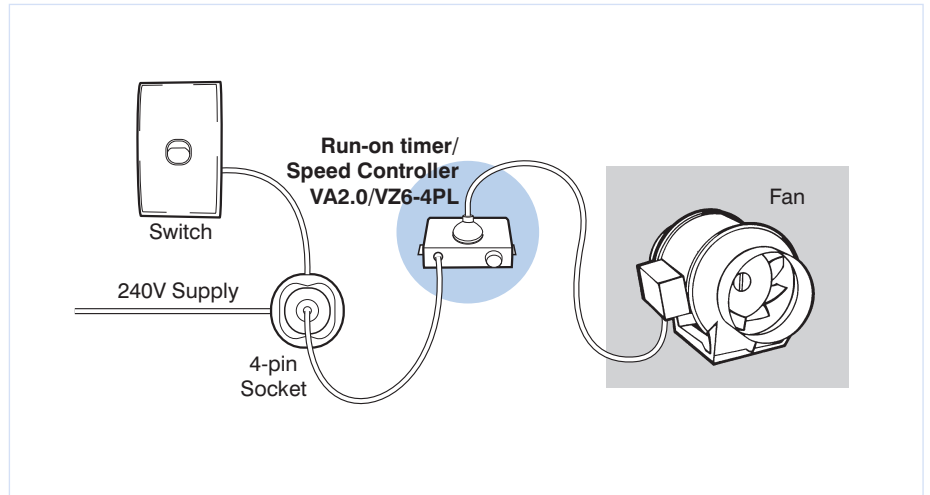

Description

The VA2.0/VZ6-4PL plug-in run-on timer and speed controller is designed to permit the supply of electricity to motors so they can continue to operate for a predetermined time. The speed controller provides infinite variation of fan speed to suit the exhaust air requirements.

This unit is designed for single-phase fans fitted with a 3-pin plug. The VA2.0/VZ6-4PL has a 900mm lead and 4 pin plug for connection to a 4-pin outlet.

Run-on time is fixed at 6 minutes and speed variation is between 30 and 100% of full speed.

Warning

Not to be used with fans with EC motors or inverters.

RUN-ON TIMER CONTROLLER WITH ON/OFF PUSH SWITCH



Technical Data

Model Number	Protection Degree	Input Power	Mount Type	Max. Relative Humidity	Ambient Temp.	Dimensions, mm (W x H x D)
TIMER	IP40	230V~ 50-60 Hz	Wall	90% at 35°C	from -5°C to +35°C	78 x 78 x 19.8

Description

The electronic timer controller is equipped with a relay output and it is suitable to adjust the run-on operation time of a fan.

It comes with a front knob to adjust the overrun time (from 30 seconds to 25 minutes) and an ON/OFF push button. Front yellow LED standby light indicates that the load is active. Controller can be surface or recess mounted. Max. load 2A.

POWER SENSE SWITCH & FAN CONTROL THERMOSTAT

POWER SENSE SWITCH TYPE - VZ-ISNSE



Description

The VZ-ISNSE is a 240V AC power sense switch that provides automatic on/off control of a fan or exhaust fan system. The unit detects the current of an appliance such as a clothes dryer, closing and opening the switched output relay when the load sense range parameters are met. Can be used with the VZ2-10TS, VZM0-28TS, VZ6-4PL or as a stand alone unit.

LED's indicate when load is activated.

Warning

Not to be used with fans with EC motors or inverters.

Technical Data

Model Number	Load Sense Range	Switched Output Max. Amps	Enclosure Size, mm
VZ-ISNSE	On = 2.5 - 15 amp Off = 0 - 1.5 amps	5	153W x 110H x 60D

Suggested Wiring Arrangement

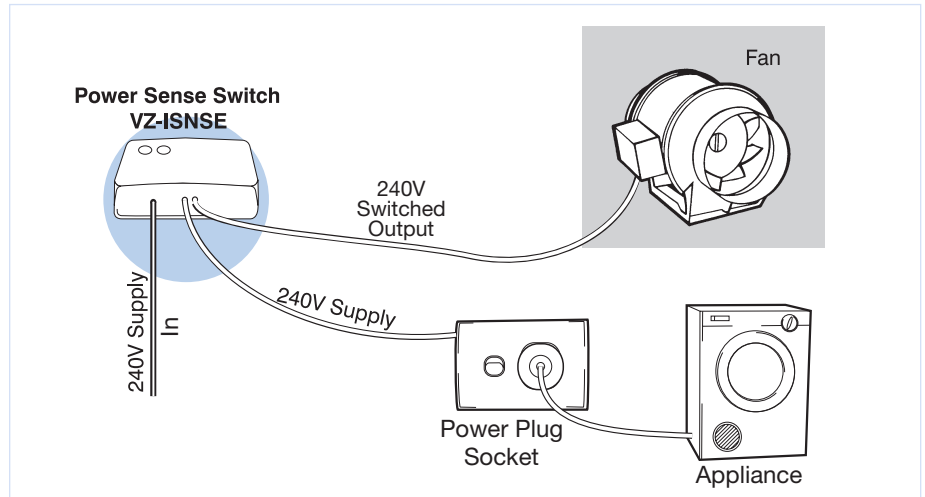

FAN CONTROL THERMOSTAT



Description

The Fan Control Thermostat has been developed to control the operation of a 240-volt fan based on the setting made on the thermostat dial.

It can be set to turn on a fan when the room temperature is either higher or lower than the set point. This makes it an ideal addition for Heat Transfer Kits as it turns on the fan to efficiently transfer warm air from one room to another when the temperature falls below the thermostat's set point. It can also be used with supply air systems to provide fresh air to a given space when the temperature reaches the dial setting.

The Thermostat can also be used in applications such as computer server rooms, switch rooms and commercial kitchens where the accumulation of hot air needs to be extracted through the use of a ceiling, wall-mounted or in-line fans.

Technical Data

Model Number	Temperature range	Mounting	Maximum Amps	Dimensions, mm
TFC6	5°C to 30°C	Wall mountable	6.0	86W x 86H x 33D

Selection Table

The TFC6 is suitable for most 240-volt fans.

The TFC6 can be set in two modes:

Cool mode - will start the fan when the room temperature is higher than the set point.

Heat mode - will start the fan when the room temperature is lower than the set point.

Wiring Diagram

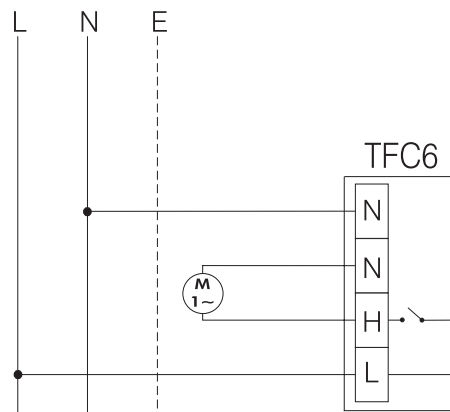

MULTIFUNCTION CONTROLLER

MULTI-FUNCTION CONTROLLER WITH LCD DISPLAY



Technical Data

Model Number

Dimensions, mm

CTRL-DSP

135W x 111H x 26D

Description

The multi-function control panel has a clean design that includes a LCD display. The simple to use buttons help the user navigate through a range of fan functions. It is easy to install and setup for use.

EC CONTROLLERS

PREMIUM MODULE



Description

The Premium Module expands an EC motor to be fully configurable and multipurpose. The Premium Module provides an integrated MODBUS interface and enables sensors to be connected directly to the EC fan.

Features

- Quick and easy to install
- Pre-set parameters control the fan's speed in proportion to demand
- Plug in Premium Module expands input/output interface on an EC fan
- Provides MODBUS interface that allows integration into existing MODBUS-RTU networks
- Premium Module is pre-configured to project specifications by Elta

The following Inputs/outputs can be connected to the AM Premium Module

- 2 x Digital input
- 2 x Analogue Input
- 1 x Analogue output
- 1 x 24V DC output (70mA)
- 1 x 10V DC output (10mA)
- 1 x Relay output (Configured to N.O. or N.C.)
- 1 x MODBUS (RS-485)

Technical Data

Model Number	Functional Extension	Configuration
DCV-CU-PREM	Via cable	pre-configured by Elta

Wiring Diagram

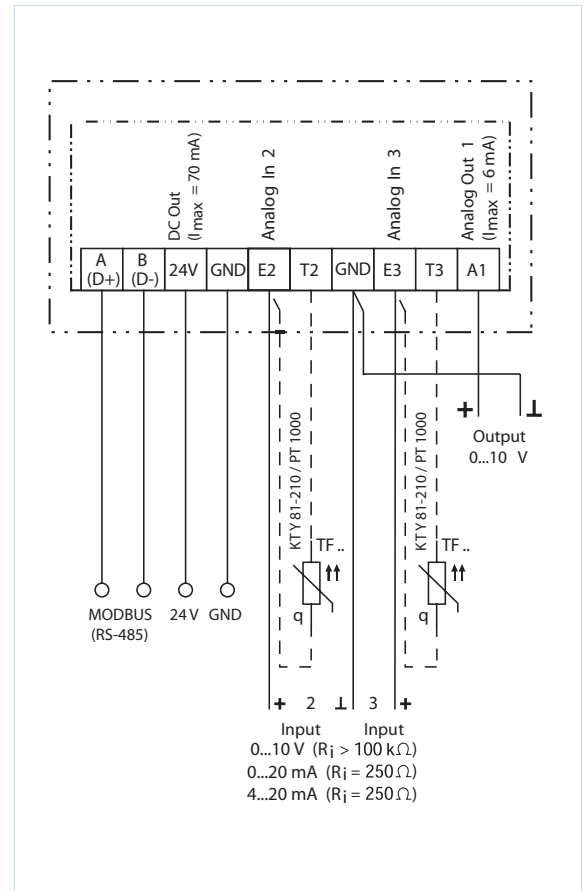

TEMPERATURE CONTROLLER



Description

The temperature controller combined with matching sensors can be used in a range of applications including extraction and supply air systems.

Features

- Quick and easy to install and commission
- Pre-set parameters control the fan's speed in proportion to demand
- EC fans with integrated control can be activated directly
- 24V supply from control unit
- Voltage input (10-24 V DC) for switch over between Set point 1 and Set point 2 (e.g. for day / night, summer / winter)

Technical Data

Model Number	Measuring Range	Mount Type	Protection Class	Dimension, mm
DCV-CU-CTG-150AV	- 50°C to +150°C	Wall	IP54	114W x 108H x 56D

Wiring Diagram

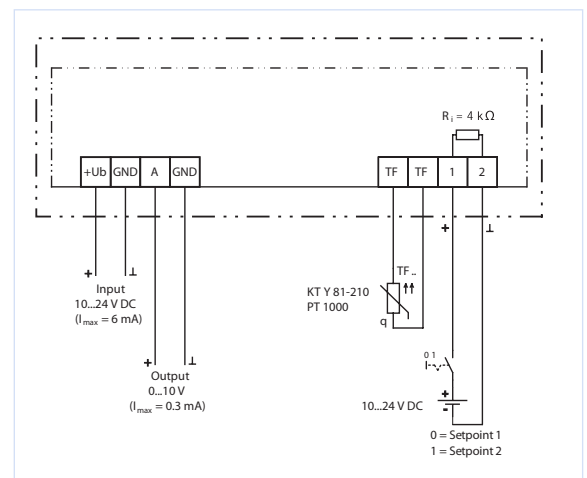

EC CONTROLLERS

UNIVERSAL CONTROLLER



Description

The Universal Controller helps create a demand control ventilation system. A complete universal controller which includes temperature, CO₂, differential pressure, air velocity and air volume control.

Features

- Quick and easy to install and commission
- Pre-set parameters control the fan's speed in proportion to demand
- Connection facility for 2 sensors
- 2 outputs 0-10 V for activation of a subsequent speed controller
- 5 digital outputs (relay) programmable (e.g. status signals, threshold values)
- 5 digital inputs programmable (e.g. enable function, target value 1/2, controller output limitation, automatic/manual switch over)
- Integration into bus system via RS485 interface, MODBUS-RTU
- Supply as either 24V supply from control unit or 240V from AC supply

Technical Data

Model Number	Input Power	Mount Type	Clock	Protection Class	Dimensions, mm (W x H x D)
DCV-CU-CXE-AV	1~ 230V 50/60Hz	Wall	-	IP54	223 x 200 x 115
DCV-CU-CXE-AVE	1~ 230V 50/60Hz	Panel mount	-	IP54	166 x 106 x 105 (max)
DCV-CU-CXE-AVC	1~ 230V 50/60Hz	Wall	Real-time clock	IP54	223 x 200 x 115
DCV-CU-CXG-48AV	24V AC	Wall	-	IP54	223 x 200 x 115
DCV-CU-CXG-48AVE	24V AC	Panel mount	-	IP54	166 x 106 x 105 (max)
DCV-CU-CXG-24AV	24V DC	Wall	-	IP54	223 x 200 x 115
DCV-CU-CXG-24AVE	24V DC	Panel mount	-	IP54	166 x 106 x 105 (max)
DCV-CU-CXE-400AV	3~ 400V 50/60Hz	Wall	-	IP54	223 x 200 x 115
DCV-CU-CXE-400AVC	3~ 400V 50/60Hz	Wall	Real-time clock	IP54	223 x 200 x 115

Wiring Diagram

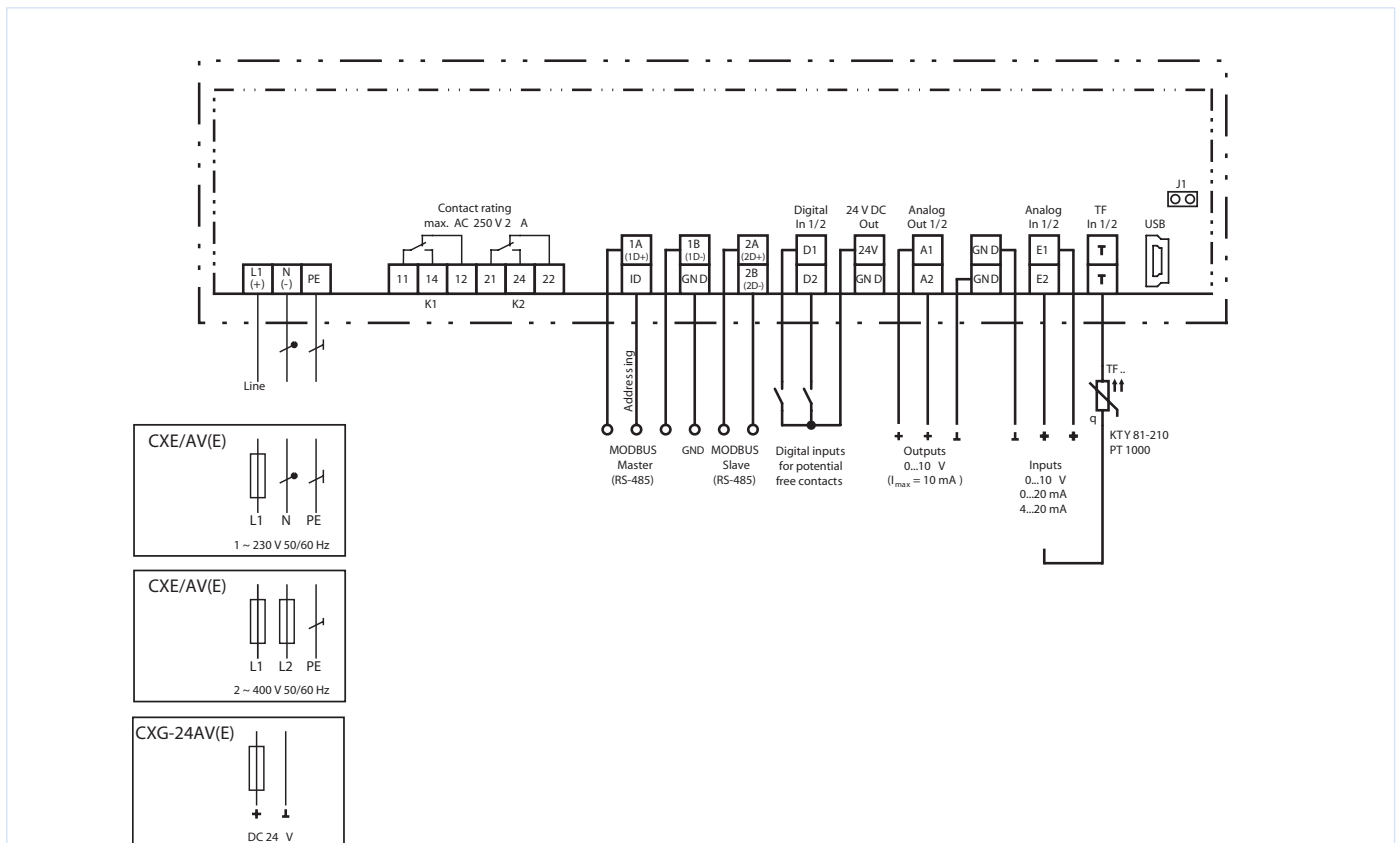

EC CONTROLLERS

PRESSURE CONTROLLER



Wiring Diagram

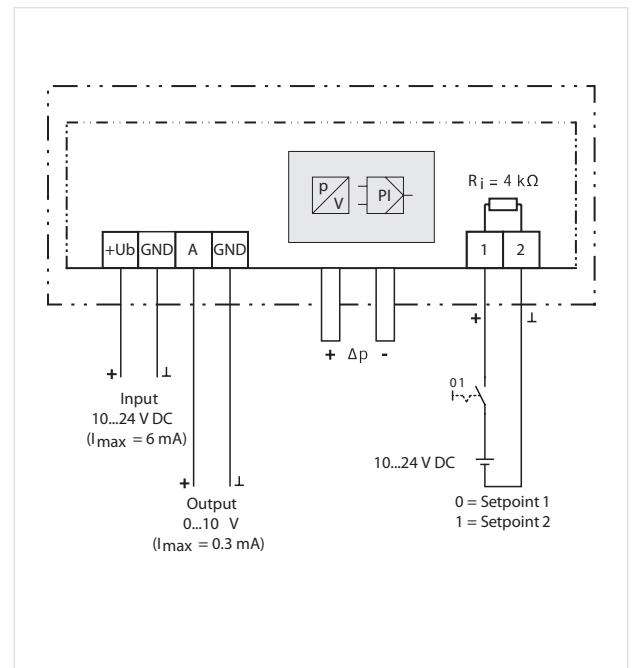

Description

The differential pressure controller (non-aggressive gas) can be configured with four measuring ranges. Depending on the desired set point value and control range, the sensor control module generates 0-10 V to control the EC fan.

Features

- Quick and easy to install and commission
- Pre-set parameters control the fan's speed in proportion to demand
- 24V supply from control unit
- Digital input (10-24V DC) for switch over between Set point 1 and Set point 2 (e.g. for day / night, summer / winter)

Technical Data

Model Number	Measuring Range	Mount Type	Protection Class	Dimensions, mm
DCV-CU-CPG-200AV	0-50/100/150/200 Pa	Wall	IP54	114W x 108H x 56D
DCV-CU-CPG-1000AV	0-200/300/500/1000 Pa	Wall	IP54	114W x 108H x 56D

0-10V EC SPEED CONTROLLER



Wall mounted



Standalone

Technical Data

Model Number	Max. mA	Mounting	Dimensions, mm
DCV-POT10K-WM	25	Recess	72W x 117H x 40D
DCV-POT10K-FM*	25	Standalone	110W x 35H x 135D

*The DCV-POT10K-FM is designed to be mounted on or near the fan enclosure.

Description

The manually adjustable, 0-10V speed controller has been specially developed for stepless speed adjustment of EC fans that accept a 0-10V control signal. It is available as a wall mount switch plate and a standalone controller for mounting on or near the fan enclosure.

Features

- Quick and easy to install.
- Incorporates an enable/disable switch.
- EC fans with integrated speed control can be activated directly.

Additional Information

The 0-10V speed controller is designed for 10VDC only. It requires a 10V (25mA) power supply.

Wiring Diagram

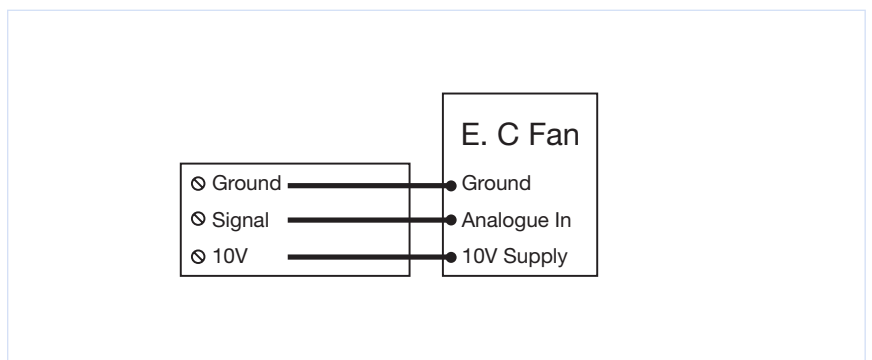

EC SENSORS

TEMPERATURE SENSORS



TFR / TFR-E

Room sensor with plastic housing for outdoor and industrial use.



TFW

Room sensor with plastic housing for indoor use only.



TFT / TFT(XL)

Immersion sensor with brass sensor rod and immersion sleeve.



TFA

Contact sensor with stainless steel sensor rod.



TFK

Duct sensor with plastic housing and stainless steel sensor rod.

Description

The Elta range of temperature sensors measure ambient air according to parameters set in the control unit.

- These sensors use a silicon PTC element that changes its resistance depending on the ambient temperature
- All TF temperature sensors are passive sensors, so they do not require power

Wiring Diagram

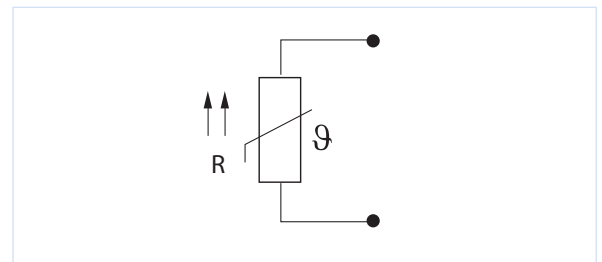

Technical Data

Model Number	Permissible Temperature Range	Protection Class	Sensor Sleeve/ Material	Dimensions, mm	Connection Cable Length, m
DCV-TEMP-TFR	-20°C to +60°C	IP54	-	75W x 75H x 37D	-
DCV-TEMP-TFR-E	-20°C to +60°C	-	-	Built-in sensor of TFR	-
DCV-TEMP-TFW	-35°C to +70°C	IP20	-	84W x 84H x 23.5D	-
DCV-TEMP-TFT	-20°C to +105°C	IP43	Ø7mm x 50mm/ Brass	-	1.9
DCV-TEMP-TFT-XL	-20°C to +105°C	IP43	Ø7mm x 50mm/ Brass	-	4.0
DCV-TEMP-TFA	-20°C to +85°C	IP67	Ø6mm x 50mm/ Stainless steel	-	2.0
DCV-TEMP-TFK	-50°C to + 120°C	IP65	Ø7mm x 135mm/ Stainless steel	50W x 65H x 44D	-

EC SENSORS

DIFFERENTIAL PRESSURE SENSORS



Description

Designed for measuring differential pressure in air ducts, fan inlet nozzles and roof mounted fans. The differential pressure sensor is connected to the ventilation system by two pressure connections and can regulate the air pressure or air volume flow via the control unit.

Features

- Output of 0 - 10V signal proportionally over the respective measuring range
- Suitable for non-aggressive, gaseous mediums
- Comes with 0.5m connection cable.
- Vertical mounting position is recommended

Wiring Diagram

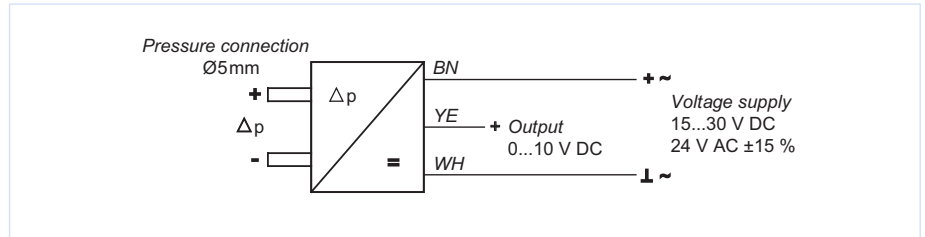

Technical Data

Model Number	Measuring Pressure Range (Pa)	Protection Class	Dimensions, mm
DCV-PA-DSG50	0 - 50	IP65	70W x 70H x 50D
DCV-PA-DSG200	0 - 200	IP65	70W x 70H x 50D
DCV-PA-DSG500	0 - 500	IP65	70W x 70H x 50D
DCV-PA-DSG1000	0 - 1000	IP65	70W x 70H x 50D

AIR VELOCITY SENSORS



Description

The air velocity range of sensors has been specially optimised for non-aggressive gaseous mediums. The measuring head can be positioned within the duct in any direction. The air velocity sensor is available as 2 options; with a Ø12mm x 200mm adjustable extension and with a 2 metre sensor cable.

Features

- Very high measuring accuracy from 0.15m/s.
- Output of 0 - 10V or 4 - 20mA, proportionally over the respective measuring range.
- Easy to mount using the mounting flange included
- Requires 24V supply from control unit.
- Measuring range and response time can be selected by altering the jumper settings.

Wiring Diagram

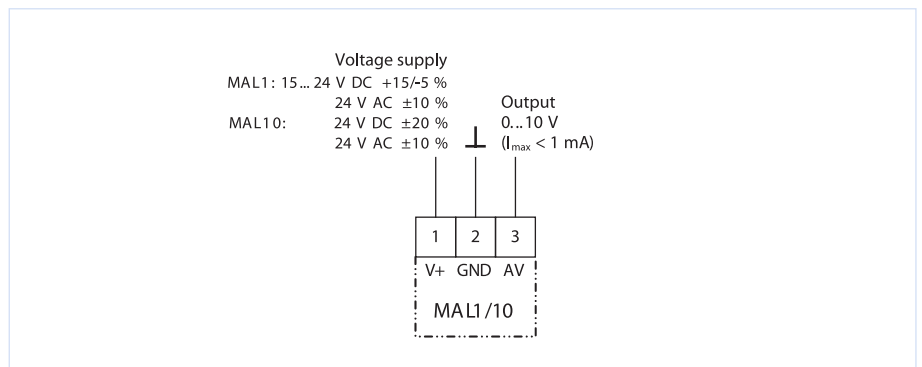

Technical Data

Model Number	Protection class	Sensor head, mm	Sensor Post, mm	Sensor Cable, mm	Velocity Range, m/s
DCV-AV-MAL1	IP65 (Head IP20)	80W x 80H x 35D	Ø12 x 200	-	0-2
DCV-AV-MAL1X	IP65 (Head IP20)	80W x 80H x 35D	-	2000	0-2
DCV-AV-MAL10	IP65 (Head IP20)	80W x 80H x 35D	Ø12 x 200	-	0-20

EC SENSORS

COMBINED HUMIDITY AND TEMPERATURE SENSOR



Technical Data

Model Number	Permissible Temperature range	Protection class	Sensor Head, mm	Sensor Post, mm
DCV-HT-MFTG-100V	-40°C to +60°C	IP65	80W x 80H x 37D	Ø12 x 82

Description

Can provide accurate measurement of both relative humidity and temperature in air conditioned and refrigerated conditions. The sensing element contains a special protective coating for use in polluted environments.

Features

- Relative humidity measurement range: 0-100%.
- The temperature measurement is made by the change in resistance on the built-in PTC (Positive Temperature Coefficient) element (KTY81-210).
- High grade sintered stainless steel element acts as a filter against contaminants.

Wiring Diagram

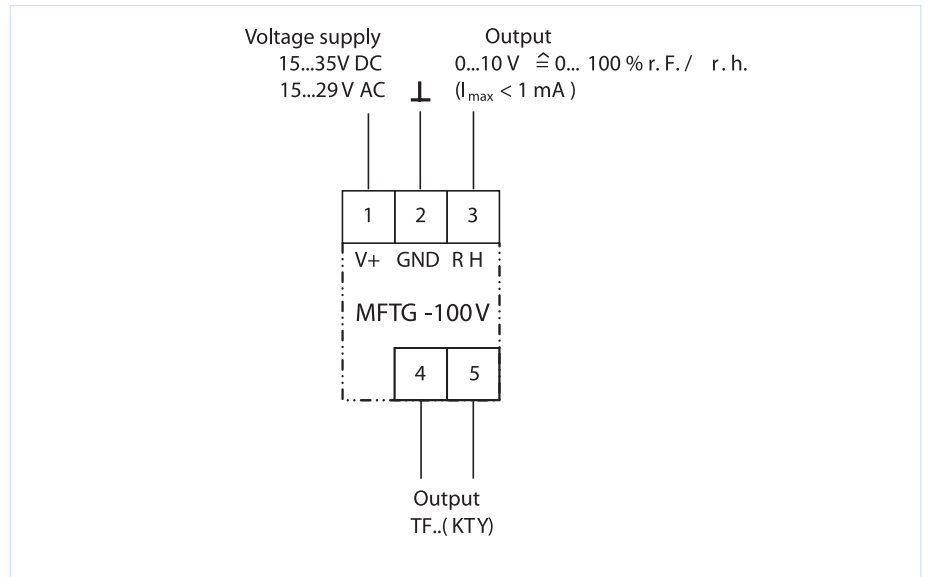

COMBINED CO₂, HUMIDITY AND TEMPERATURE SENSOR



Technical Data

Model Number	Protection Class	Sensor Head, mm
DCV-CB-MCFTG-3AV	IP20	80W x 100H x 26D

Description

A combined sensor designed to measure CO₂ concentration, relative humidity and temperature. Typical applications include occupied spaces such as office buildings, conference rooms and education centres. Measurements can be taken either separately or combined.

Features

- Values are shown alternatively on an integrated display.
- Measurement range:
 - CO₂: 0-2000 ppm
 - Humidity: 0-100%
 - Temperature: 0°C to +50 °C
- 24V AC ±20 %

Wiring Diagram

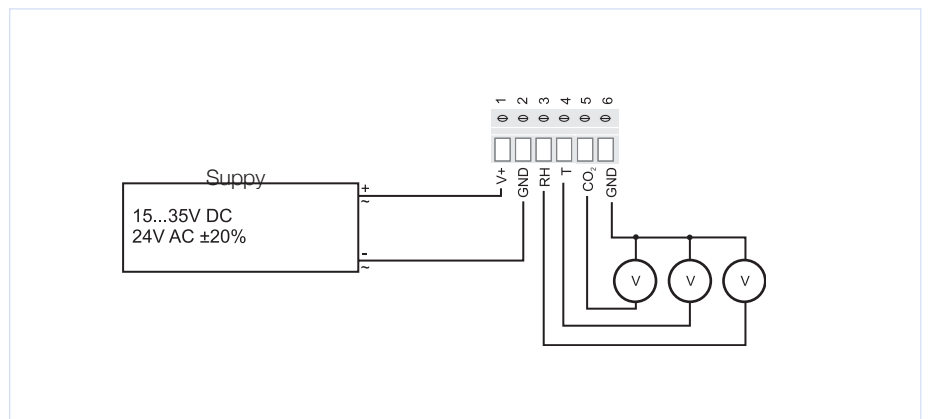

EC SENSORS

DIFFERENTIAL PRESSURE SWITCH



Description

High-precision switch for monitoring differential pressure and negative pressure of gaseous and non-corrosive media.

Features

- The desired switching point between NO and NC is set by a rotary switch (scale 0.2 to 3 mbar).
- Vertical mounting position is recommended

Applications

- Pressure control for central extraction and variable air volume systems (VAV).
- Airflow monitoring of warm air heaters.
- Frost protection for heat exchangers.
- Vee-belt and filter monitoring.
- Controlling and monitoring gas boilers.

Wiring Diagram

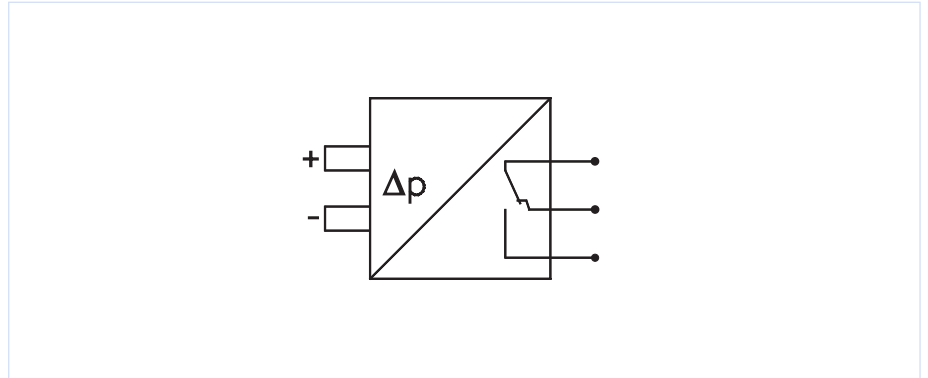

Technical Data

Model Number	Measuring range (Pa)	Protection Class	Head, mm
DCV-PA-MPR300	20-300	IP54	88W x 88H x 53D

HUMIDISTAT CONTROLLER WITH ON/OFF SWITCH

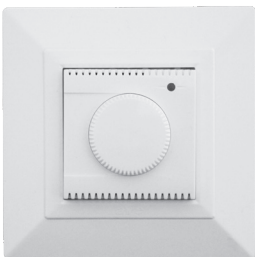

Technical Data

Model Number	Protection Class	Input Power	Mount Type	Max. Relative Humidity	Ambient Temp.	Dimensions, mm (W x H x D)
SEN-HY	IP40	230V~ 50-60 Hz	Wall	95% at 35°C	from 0°C to +35°C	78 x 78 x 19.8

Description

The electronic humidistat controller is designed to automatically activate/deactivate the fan when the relative humidity goes over/beneath the set threshold.

User can adjust the humidity threshold between 50% and 95% R.H. Integral over-run timer adjustable from 1 to 25 minutes. Front yellow LED standby light indicates that the load is active. Controller can be surface or recess mounted. Max. load 2A.

EC SENSORS

CONTROLLER WITH INFRARED SENSOR



Technical Data

Model Number	Protection Class	Input Power	Mount Type	Max. Relative Humidity	Ambient Temp.	Dimensions, mm (W x H x D)
SEN-PIR	IP40	110-240V~ 50-60 Hz	Wall	90% at 35°C	from 0°C to +35°C	78 x 78 x 19.8

Description

The controller comes with an infra-red sensor and four different operation modes: Automatic, Twilight, Forced ON and Semi-automatic. The sensor is equipped with a Fresnel lens plus control buttons to set the time and various thresholds.



Elta Asia Sdn Bhd

Tel +603 7846 0340
Email info@elta.asia

elta.asia

CVSRT-01-2026 Issue A



FS 676456