



Car Park Ventilation

**ELTA**

Mechanically vented car parks are designed to operate with either traditional ducted or modern impulse ventilation systems. Our car park fans operate on well-proven tunnel ventilation principles, producing a high velocity jet that, as it diffuses, imparts thrust to the surrounding air through mixing and entrainment.

**We manufacture a range of fans including axial and centrifugal variants for both general ventilation and emergency situations in car park applications.**

Our JetVent range includes induction and impulse ventilation models specifically developed to operate as both general ventilation and for once-only, emergency extract mode at temperatures of up to 400°C.

The product design eliminates the requirement for ducted systems, making efficient use of the limited space of enclosed car parks, in addition to reducing power consumption and the associated running costs.

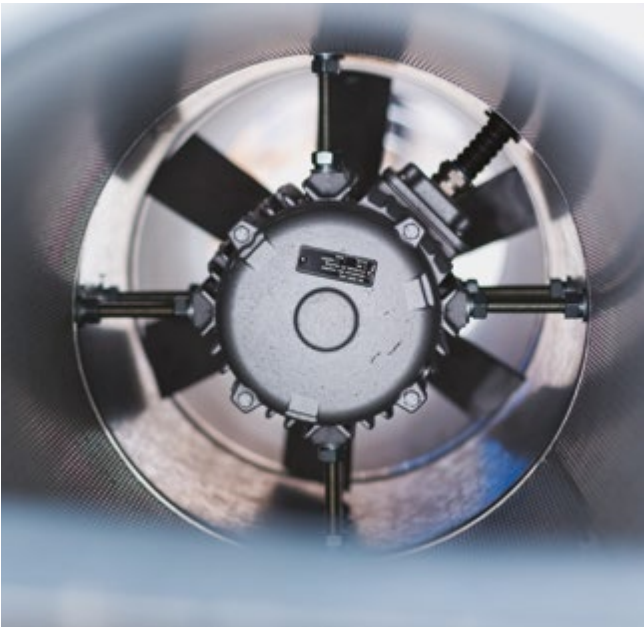



# PART OF ELTA GROUP

**Across all of our people, in all of our businesses, on all continents on which we operate, Elta Group has one purpose: To enhance life through air.**

For 20 years we have been a proudly independent, family-owned group, but our foundations were laid over 45 years ago. Our foundations were built on an entrepreneurial spirit and a clear vision of meeting market needs and improving air quality. These have seen us become a leader in high-integrity solutions that move, filter, treat and distribute air, from agriculture to building services to applied technology. We're never standing still, always living and breathing our cause, and looking to the horizon.

[eltagroup.com](http://eltagroup.com)

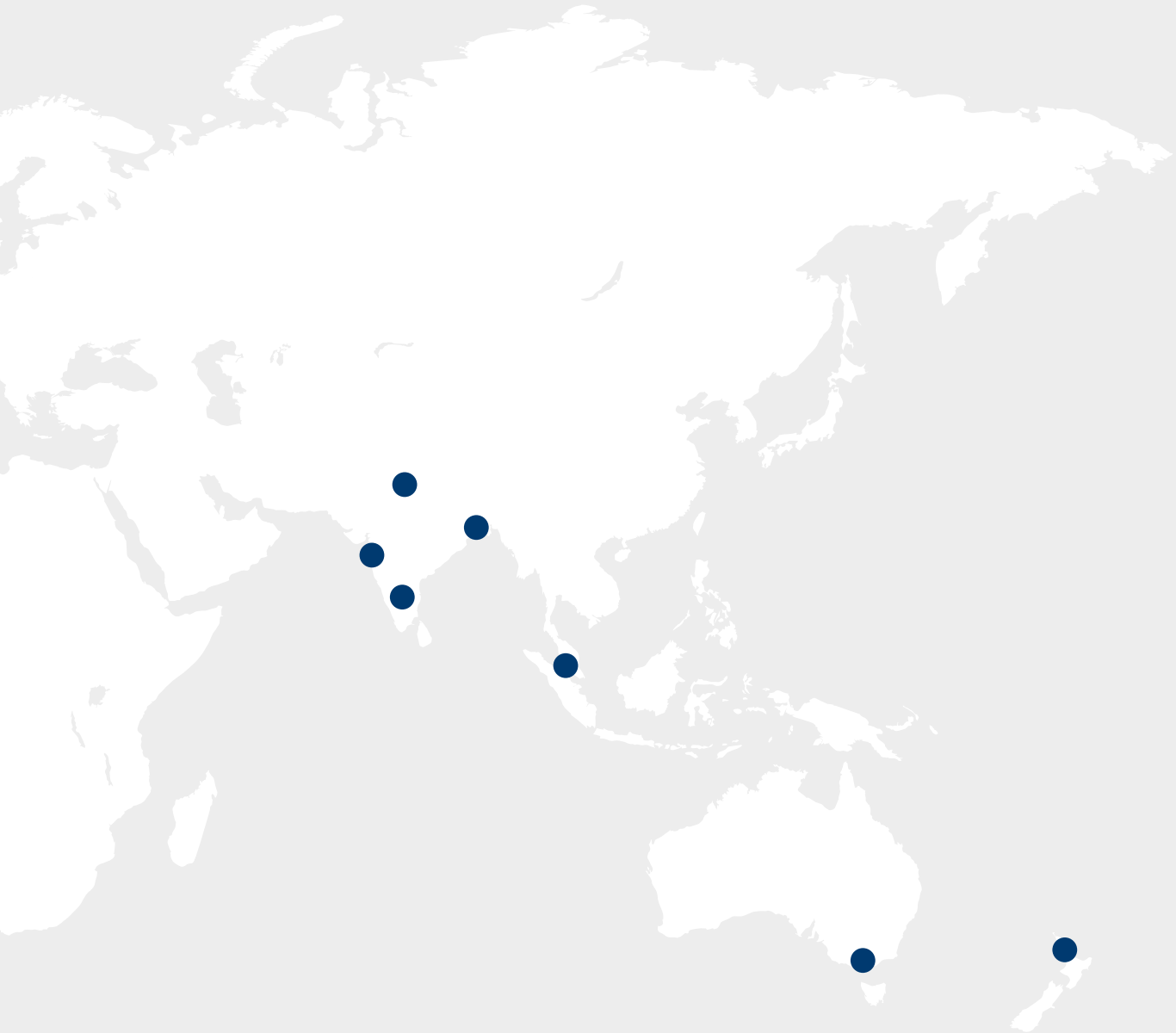

Europe  
Asia  
Australasia  
**REGIONS**

Building Services  
Applied Technology  
Agriculture  
International  
**MARKETS**

Fans  
Air Handling  
Heat Recovery  
Filtration  
Natural Ventilation  
Acoustics  
Air Distribution  
Controls  
Heating  
Cooling  
Welfare  
Lighting  
**PRODUCTS**





# Impulse Ventilation

**The impulse ventilation system is based on a number of small, strategically located high velocity fans in place of the distribution ductwork traditionally used in car parks.**

Impulse fans operate on well-proven tunnel ventilation principles, producing a high velocity jet which thrusts against the air in front of the fan imparting momentum to all the surrounding air through entrainment as it diffuses. The volume of entrained air is significantly greater than that passing through the fan. The impulse fans are carefully positioned to direct the airflow towards the main extract fan intake points.

# JetVent Axial Impulse Fans

**JetVent Axial Impulse fans have been specifically designed to provide a high velocity airflow to help overcome problems caused by obstructive structural beams and low overall ceiling heights found in car parks. The innovative design of JetVent Axial Impulse fans provides major benefits in terms of reduced installation and running costs as well as effective smoke control.**

Technical excellence and innovation in design are the cornerstones of an Elta product - JetVent is no exception to this approach. The harmony of our engineering excellence and technical sophistication combine to provide a first class product which meets demanding smoke, as well as general fume, applications.

With tomorrow's technology at our finger tips, utilising market leading software, Elta can pinpoint, analyse and make design changes and improvements without the expense of conventional prototyping, working with our customers to meet their specific needs.

# Conventional & Impulse Ventilation

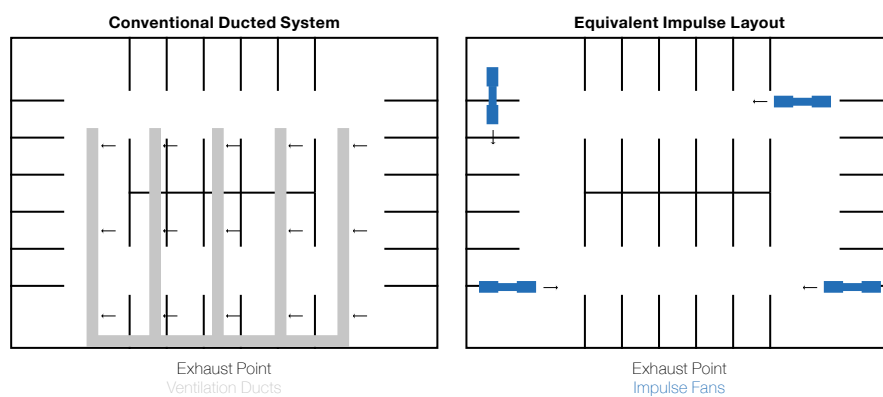

The distribution ducting used in traditional systems is replaced by a number of small JetVent impulse fans to direct the airflow across the designated area. Without the distribution duct resistance, smaller exhaust and supply fans and / or motors can be used.

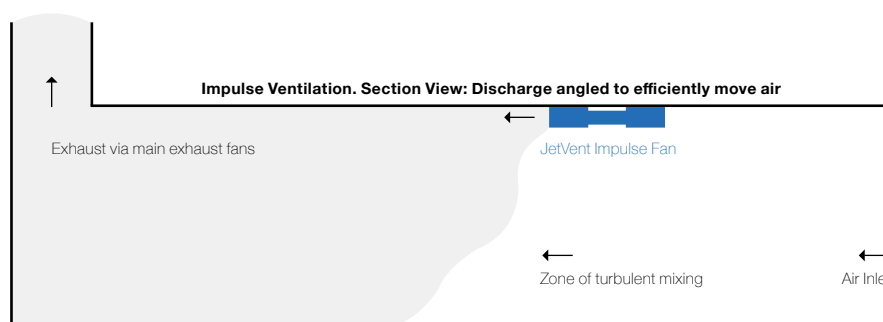

# Features & Benefits

**The JetVent Axial Impulse fan range is available with either unidirectional or truly reversible airflow. JetVent can run in either normal extract mode or once only smoke operation at up to 400°C for 2 hours which means cost savings as a single fan provides both general and smoke extract requirements.**

## Better Security

The elimination or reduction in ductwork means a safer, lighter environment with better security due to the increased visibility.

## Low Maintenance

With no ductwork, maintenance costs are reduced as there is no ducting to become blocked, damaged or subject to leakage.

## Design Appeal

The integral bell mouth inlet has a streamlined appearance for improved performance and sound.

## No Ductwork

By adding momentum to the air, JetVent thrusts air towards the desired extract points to ensure stagnant fumes and smoke are cleared effectively and efficiently. This principle eliminates the requirement for ductwork within a car park, as the JetVent effectively transfers the polluted air, allowing for better use of limited space in underground facilities.

## Cost Effective

JetVent provides the scope for reduced installation and overall construction build costs compared with traditional ducted systems. The high efficiency impellers make this a very economical method of moving high volumes of air.

## Robust Design

JetVent axial fans are of a robust, heavy duty construction for added strength and durability. Fan casings are heavy gauge, sheet steel, roll formed and welded and hot dipped galvanised after fabrication to BS EN ISO 1461.



# Performance & Dimensional Data

Motors shown below are suitable for the following:

- A** General use at temperatures (ambient) +40°C
- B** One off high temperature use of 300°C for 2 hours
- C** 400Volt / 3 Phase / 50Hz Electrical Supply
- D** All thrust figures are measured under test conditions
- E** Volume flow and velocity figures shown may have been calculated in accordance with test requirements
- F** All the test data shown has been prepared in accordance with ISO 13350 1999 / BS 848-10-1999

## Flanged Units

### JetVent Unidirectional High Thrust

Product Code	Thrust Newtons	Volume Flow Rate m <sup>3</sup> /s	Velocity m/s	Sound Pressure dBA @ 1m	Speed r/min	Motor Power kW	FLC Amps	SC Amps	Absorbed Power kW
LCS-031-CPU 2/4-3	34/9	1.49/0.77	19.20/9.90	68/50	2836/1460	1.30/0.28	2.65/0.80	14.80/3.61	1.16/0.18
LCS-035-CPU 2/4-3	53/14	2.12/1.08	21.40/10.90	71/53	2909/1484	2.53/0.58	5.25/1.70	27.80/5.44	2.04/0.31
LCS-040-CPU 2/4-3	86/22	3.04/1.55	24.20/12.30	71/54	2898/1478	2.53/0.58	5.25/1.70	27.80/5.44	2.52/0.38

Product Code	A	B	C	D	E	F	G (max)	Weight (kg)
LCS-031-CPU 2/4-3	250	300	315	265	447	9	1751	51
LCS-035-CPU 2/4-3	348	400	355	305	443	9	1839	60
LCS-040-CPU 2/4-3	339	400	400	350	523	9	2323	72

#### Dimensional Drawing

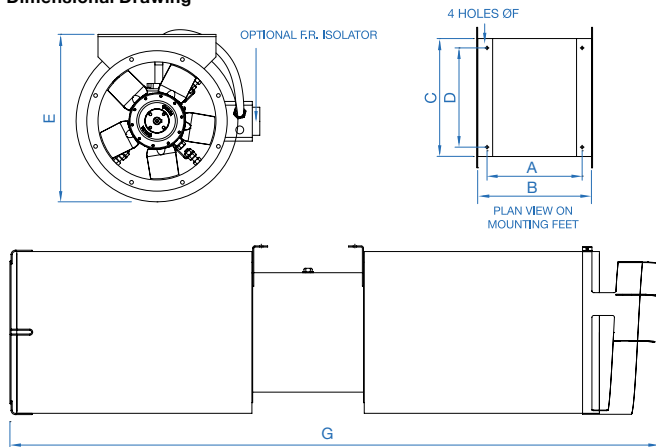

#### Wiring Diagram

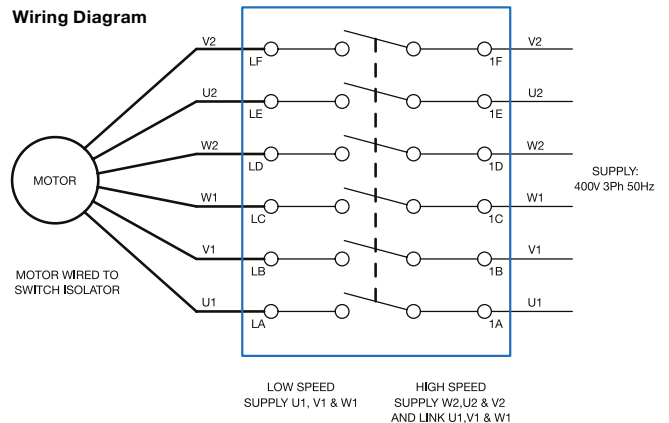

# Flanged Units

## JetVent Truly Reversible High Thrust

Product Code	Thrust Newtons	Volume Flow Rate m <sup>3</sup> /s	Velocity m/s	Sound Pressure dBA @ 1m	Speed r/min	Motor Power kW	FLC Amps	SC Amps	Absorbed Power kW
<a href="#">LCS-031-CPR 2/4-3</a>	24/6	1.26/0.64	16.10/8.20	66/48	2895/1470	1.30/0.28	2.65/0.80	14.80/3.61	0.86/0.13
<a href="#">LCS-035-CPR 2/4-3</a>	43/11	1.91/0.96	19.30/9.70	70/53	2946/1488	2.53/0.58	5.25/1.70	27.80/5.44	1.54/0.23
<a href="#">LCS-040-CPR 2/4-3</a>	79/20	2.91/1.48	23.10/11.80	72/55	2900/1476	2.53/0.58	5.25/1.70	27.80/5.44	2.52/0.38

Product Code	A	B	C	D	E	F	G (max)	Weight (kg)
<a href="#">LCS-031-CPR 2/4-3</a>	250	300	315	265	447	9	1876	52
<a href="#">LCS-035-CPR 2/4-3</a>	348	400	355	305	443	9	2045	60
<a href="#">LCS-040-CPR 2/4-3</a>	339	400	400	350	523	9	2440	73

### Dimensional Drawing

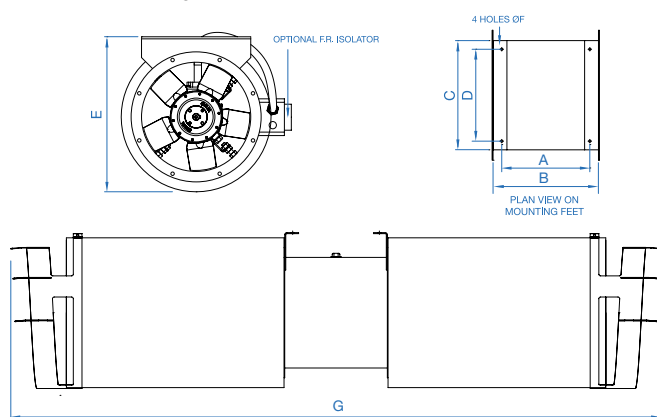

### Wiring Diagram

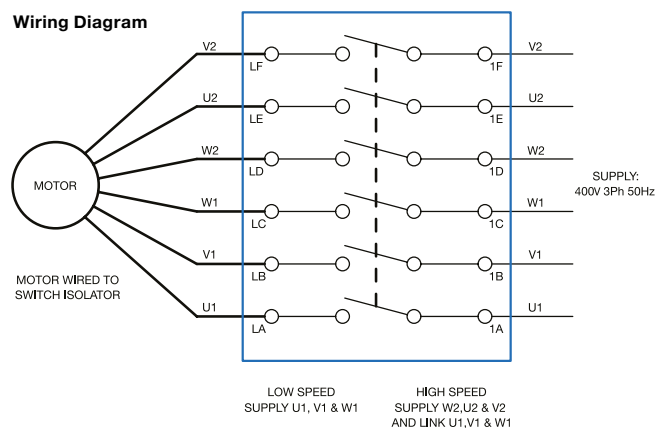

### Notes

- All dimensions are expressed in mm.
- All dBA figures shown are free field sound pressure levels at 45° to inlet/outlet.
- All starting currents shown are direct online (DOL). Air density used in all figures is 1.2kg/m<sup>3</sup>.
- Low speed provisions provided by use of inverters.





# Induction Ventilation

The ventilation level to be provided within the car park (in order to limit the concentration of carbon monoxide and other vehicle emissions and to remove smoke in the event of a fire) can be found in the relevant Building Regulations and in BS 7346-7:2006 Components for smoke and heat control systems. Code of practice on functional recommendations and calculation methods for smoke and heat control systems for covered car parks.

# The Principles of JetVent

**JetVent induction fans have been specifically designed to provide a high velocity, laminar airflow in a reduced height profile to help overcome problems caused by obstructive structural beams and low overall ceiling heights found in car parks. The innovative design of JetVent induction fans provides major benefits in terms of reduced installation and running costs as well as effective smoke and contaminant removal.**

The induction ventilation system is based on a number of small, strategically located high velocity fans in place of the large and expensive distribution ductwork traditionally used in car parks. Induction fans operate on well-proven tunnel ventilation principles, producing a high velocity jet which adds momentum to the air in front of the fan imparting thrust to all the surrounding air through mixing and entrainment as it diffuses. The volume of entrained air is significantly greater than that passing through the fan.

The induction fans are carefully positioned to direct the airflow towards the main extract fan intake points. The main extract fans are sized to provide the required flow rates, however, given the reduced need for, or complete elimination of ducting, the resulting reduction in system resistance means they are typically smaller and consume less energy.

Induction fan performance is rated in terms of the thrust developed by the fan, which is the product of the mass flow rate times the change in velocity, i.e. volume flow rate times the air density times the fan outlet velocity, and is measured in Newtons.

# Conventional & Induction Ventilation

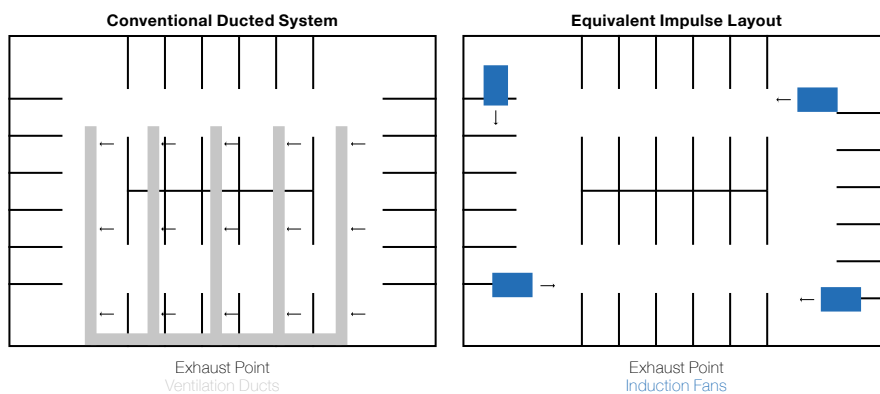

The distribution ducting used in traditional systems is replaced by a number of small JetVent centrifugal induction fans to direct the airflow across the designated area. Without the distribution duct resistance, smaller exhaust and supply fans and / or motors can be used.

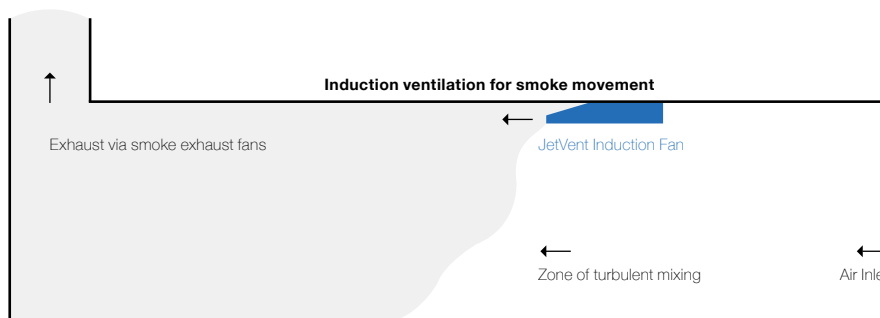

# Features & Benefits

**The JetVent centrifugal induction range comprises 50N or 100N thrust types that conform to European Standard EN12101-3. The range is suitable for ambient temperature operation as well as once only, 2 hour high temperature smoke conditions up to 400°C. The two speed motor is suitable for frequency inverter speed control on high speed.**

## Cost Effective

JetVent provides the scope for reduced installation and overall construction build costs compared with traditional ducted systems. The high efficiency impellers make this a very economical method of moving high volumes of air.

## Rigorous Testing

JetVent is independently tested to meet the exacting standards of EN 12101-3 for operating at 300°C for 2 hours. Performance is tested to BS848 - 10:1999 Fans for general purposes - Performance testing of jet fans.

## Air Quality

JetVent induction fans provide an improvement in air quality achieved by mixing the air more effectively, which means the potential risk of contaminant accumulation (beyond specific requirements) is overcome.

## Ingress Protection

A minimum protection to IP55 on electrics improves reliability and ease of cleaning by means of pressure washing components. The unit is supplied as standard with a fitted IP55 terminal box or an optional lockable fire rated isolator.

## Robust Design

The powder coated mild steel fan casing provides a robust construction, which is very resistant to potential corrosion. The integral guard is designed to protect against the rotating impeller parts. The guard is finger proof and bright zinc plated.

## Slim Profile

The slim profile design of JetVent allows designers to overcome problems caused by obstructive structural beams and low overall ceiling heights, without compromising performance characteristics.

## Better Security

The elimination or reduction in ductwork means a safer, lighter environment with better security due to the increased visibility.

## Low Maintenance

With no ductwork, maintenance costs are reduced as there is no ducting to become blocked, damaged or subject to leakage.



# Performance, Electrical & Wiring Data

Motors shown below are suitable for the following:

- A General use at temperatures (ambient) +40°C
- B One off high temperature use of 300°C for 2 hours
- C 400Volt / 3 Phase / 50Hz Electrical Supply
- D All thrust figures are measured under test conditions
- E Volume flow and velocity figures shown may have been calculated in accordance with test requirements
- F All the test data shown has been prepared in accordance with ISO 13350 1999 / BS 848-10-1999
- G dBA figure are free field sound pressure levels at 45° to the outlet

## JetVent Centrifugal

Product Code	Thrust Newtons	Volume Flow Rate m³/s	Velocity m/s	Sound Pressure dBA @ 1m	Speed r/min	Motor Power kW	FLC Amps	SC Amps	Absorbed Power kW
JISU-2-CPC-50N	54/12	1.63/0.80	28.82/14.05	75/59	1447/733	1.38/0.35	3.20/1.36	16.0/4.08	1.13/0.25
JISU-2-CPC-100N	98/18	2.65/1.35	33.19/16.87	76/60	1423/729	2.42/0.61	5.42/2.12	30.4/7.21	2.38/0.45

### Wiring Diagram

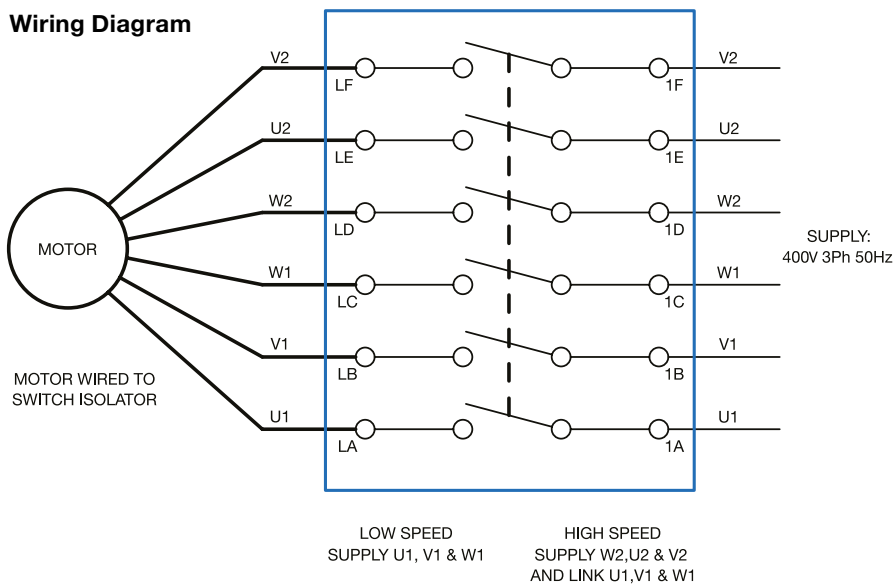

# Dimensional Data

Product Code	A	B	C	D	E	F	Weight (kg)
JISU-2-CPC-50N	1265	784	271	72	836	931	86
JISU-2-CPC-100N	1830	1262	333	70	1203	1297	160

## JISU-2-CPC-50N

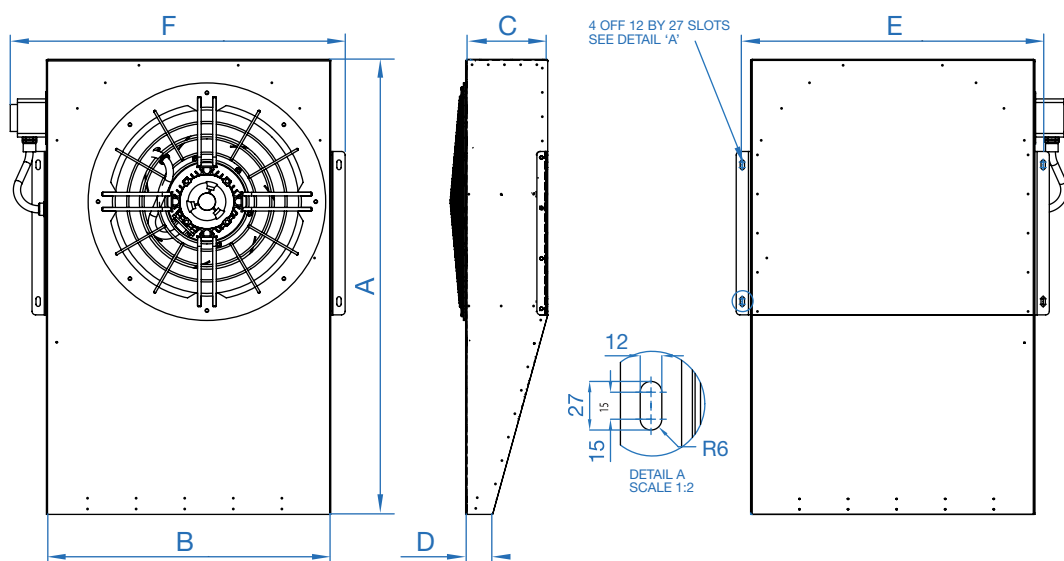

## JISU-2-CPC-100N

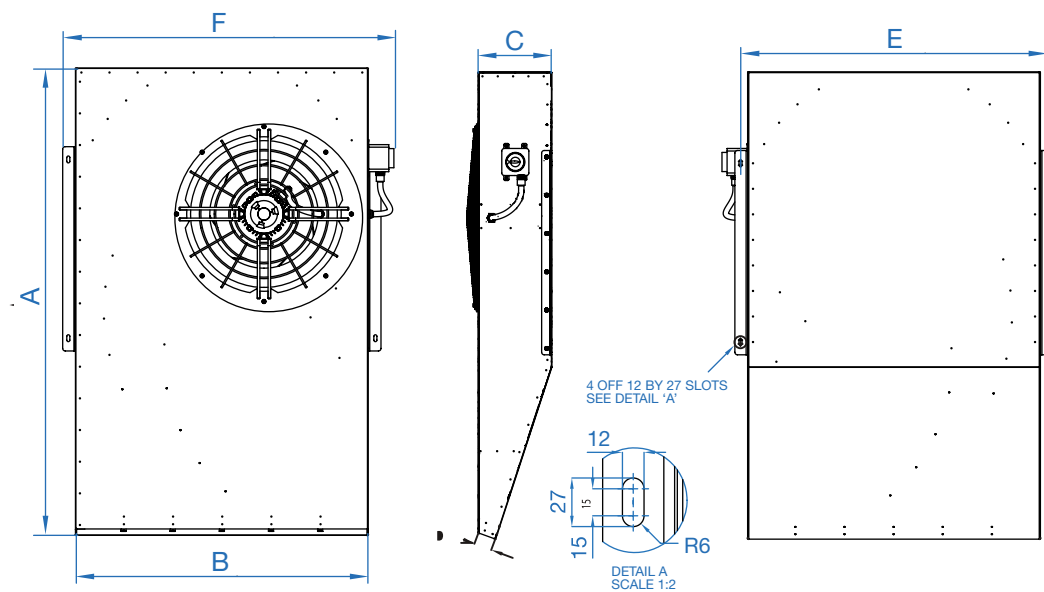



# Emergency Extract Ventilation

**Elta have been manufacturing fans for over 40 years and are one of the founding members of the Smoke Control Association, which has been instrumental in shaping modern legislation. We were also the first company to have our entire range accredited to EN12101-3 the standard to which all four of our sites across the world manufacture.**

The SmokeVent range of axial flow fans has been specifically developed for emergency smoke spill extract systems to overcome hazardous fire, smoke and fume conditions. They may operate as part of the main extract system or as dedicated fans for emergency clearance.

Our fans are of especially high design and manufacturing integrity and are made bespoke for the individual demands of the application in order to assure the safety and operation of the structure and its occupants. As high temperatures and smoke particulates can damage components, our fans have been robustly designed for continued operation in this arduous environment.

## **SmokeVent Fans**

**Our comprehensive range of SmokeVent fans are supplied for free-standing operation in ducted systems and are also suitable for installation in roof extract units. All fans are designed in accordance with EN12101-3 standards and can also be supplied to meet additional region or project specifications as required.**

With a broad range of sizes and variants we can flexibly supply models for new and refurbishment projects.

**Please contact Elta for more information on +603 7846 0340.**

# Fan Selection Program

The Elta Fan Selection Program has been designed to make fan selection faster and more efficient.

Developed from the ground up, the selection program makes it quicker and easier for you to select fans from our expansive range of products. Whether you've used the program previously or this is your first time, you will find this program a helpful part of your processes.

## Navigating the Program

To navigate between the main areas of the program, simply use the main navigation buttons at the top. The program highlights the button to show which area of the program you are in. A dedicated help source is available with the ability to define common default settings.

## Selecting a Fan

**Basic mode:** allows you to use a 5 step process to determine suitable fans, or alternatively, use a single Product Code.

**Advanced mode:** gives you complete control over the criteria for selecting your fan.

## Silencers & Acoustic Analysis

Silencer selection is available in both basic and advanced modes allowing a simple 5 step process to determine a suitable silencer or complete control over the criteria of the silencer type required.

The acoustic analysis tool allows calculations on simple systems to be made to provide a rough approximation of what noise level can be expected.

**Our Fan Selection Program has become the essential software for consultants and contractors who want fast and accurate fan and silencer selections.**

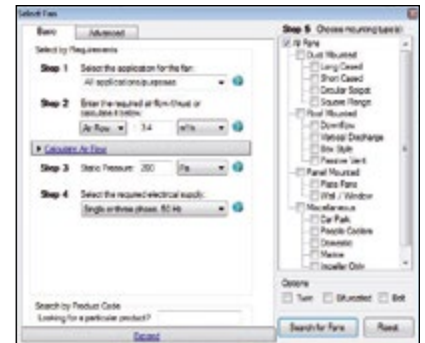

Basic Mode

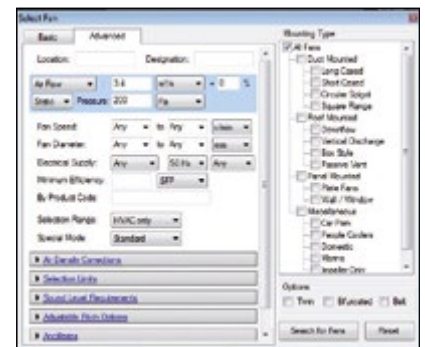

Advanced Mode

## Key Features

The latest version has been designed to make it easier for you to select, compare and schedule fans and silencers with a number of powerful new features that will help you save time.

- ✓ **A more user-friendly interface**  
Easier to find what you need based on a wide choice of criteria
- ✓ **Basic and advanced user modes**  
With guidance, use the program at the level that suits you
- ✓ **Revolutionary support for variable speed fans**  
Helps you design more energy efficient systems
- ✓ **Store all 2D .dwg and .dxf**  
For a project in a folder in one quick step
- ✓ **Conveniently view technical data**  
In a single screen and recall it at any time
- ✓ **Easily select energy efficient fans**  
And calculate running costs
- ✓ **Fully integrated PDF and Excel output**  
Promoting the efficient electronic flow of data and further compliment paperless offices

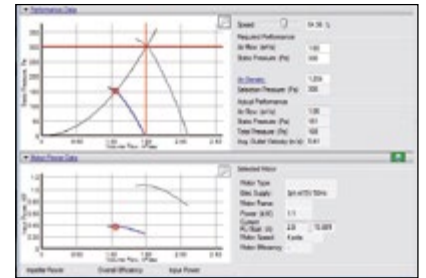

## Revolutionary Support

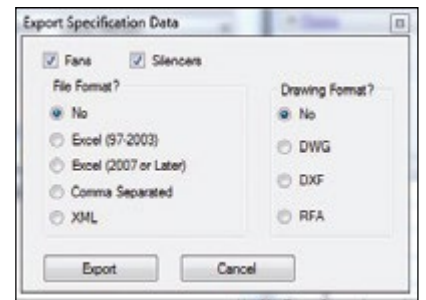

## Store All Files

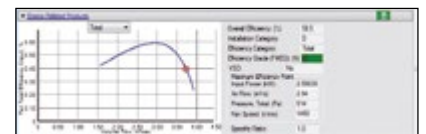

Model	Type	Flow Rate (m³/s)	Pressure Drop (Pa)	Power (W)	Efficiency (%)	Cost (£)	Energy (kWh)
LC230K-P5-20	Lang Canal A	600	1440	0.76	400	70%	80
LC230K-P5-18	Lang Canal A	600	1440	1.1	400	50%	85
LC230K-P5-16	Lang Canal A	600	1440	1.1	400	50%	85
LC230K-P5-14	Lang Canal A	600	1440	1.1	400	50%	85
LC230K-P5-12	Lang Canal A	600	1440	1.1	400	50%	85
LC230K-P5-10	Lang Canal A	600	1440	1.1	400	50%	85
LC230K-P5-8	Lang Canal A	600	1440	1.1	400	50%	85
LC230K-P5-6	Lang Canal A	600	1440	1.1	400	50%	85
LC230K-P5-4	Lang Canal A	600	1440	1.1	400	50%	85
LC230K-P5-2	Lang Canal A	600	1440	1.1	400	50%	85

## Convenient Data View



## PDF Output

Product	Type	Flow Rate (m³/s)	Pressure Drop (Pa)	Power (W)	Efficiency (%)	Cost (£)	Energy (kWh)
LC230K-P5-20	Lang Canal A	600	1440	0.76	400	70%	80
LC230K-P5-18	Lang Canal A	600	1440	1.1	400	50%	85
LC230K-P5-16	Lang Canal A	600	1440	1.1	400	50%	85
LC230K-P5-14	Lang Canal A	600	1440	1.1	400	50%	85
LC230K-P5-12	Lang Canal A	600	1440	1.1	400	50%	85
LC230K-P5-10	Lang Canal A	600	1440	1.1	400	50%	85
LC230K-P5-8	Lang Canal A	600	1440	1.1	400	50%	85
LC230K-P5-6	Lang Canal A	600	1440	1.1	400	50%	85
LC230K-P5-4	Lang Canal A	600	1440	1.1	400	50%	85
LC230K-P5-2	Lang Canal A	600	1440	1.1	400	50%	85

## Select Efficient Fans

# Customer Service

**At Elta, we pride ourselves on our integrity and reliability as a supplier. We respect that this is your project. To ensure that your project is the best it can be, when working with us, you get a partnership with as much or as little involvement from us as you need.**

We have a dedicated sales team with individuals who are specifically trained to be experts in their individual market. When you place an order with us, you are allocated a direct point of contact to ensure consistency throughout the sales process. Our dedicated projects team constantly monitor projects, giving customers updates on their order as often as they need them.

From order processing to manufacture and all the way through to delivery, our dedicated aftersales team follow an established process to ensure we don't lose visibility of the project at any stage.



# Certifications

Elta are committed to conforming to the highest standards. We hold a number of internationally recognised accreditations and certifications, in accordance with EN12101-3, including:

[Certificate of Constancy of Performance 0086-CPR-587097](#)

We are also active members of professional organisations that help to shape and direct the research, legislation, trends and issues of the present and future including:

[AMCA](#)

# ELTA



Elta Asia Sdn Bhd

147, Jalan Tudm, Kampung Subang Baru,  
40150 Shah Alam, Selangor, Malaysia

Tel **+603 7846 0340**  
Email **info@elta.asia**  
**elta.asia**

CPV-05-2026 Issue A