

GIVE A FAN A CHANCE

Installation Dos & Don'ts

GIVE A FAN A CHANCE

Installation Dos & Don'ts

Choosing the right fan for the right application is paramount, which is why every product in our range is designed and manufactured to provide characteristics that are specific to the application it has been designed for. We vigorously test all of our products before they leave our warehouse but an incorrect installation can greatly affect performance.

The installation guide given here illustrates a number of situations that should be avoided when installing fans and attenuators. This guide is not comprehensive enough to be used in place of an installation manual. If you are in doubt, please download the installation & maintenance guide for your product from our website at elta.asia or send a copy of your proposed installation to info@elta.asia so that our engineers can assess it and provide any necessary feedback.

AXIAL FANS

As a result of design improvements, Axial Flow Fans can offer higher efficiencies and lower noise levels than previous designs; typically compact, easy to install and competitively priced, they are suitable for a multitude of applications. The air flow is straight through the fan (i.e. in an axial direction).

Figure 1: Inlet cones

Use inlet cones for Axial Fan free air intakes to improve performance and noise level.

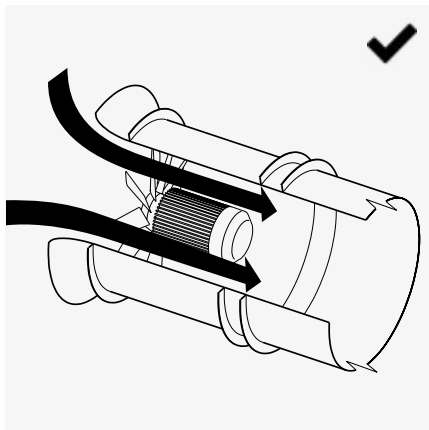

By fitting a correctly designed inlet cone, the airflow to the impeller will be uniform resulting in the performance being optimised and minimum noise level generated.

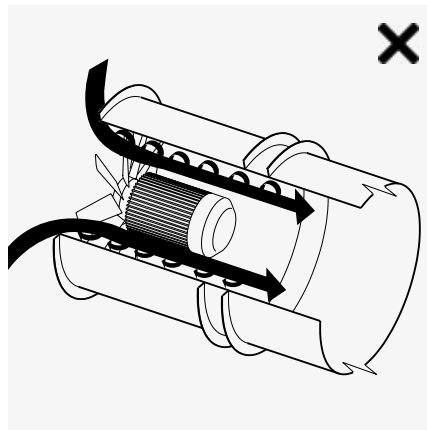

An abrupt entry will generate turbulence at the impeller. Please note: blade tips will be starved of air which reduces pressure development capability, induces stall and increase the noise level generated by the fan.

Figure 2: Turning vanes at sharp bends

Fit turning vanes in elbows adjacent to axial fans.

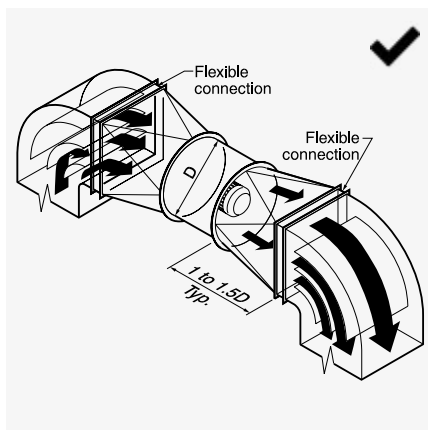

Square-to-round transitions and turning vanes in elbows assists uniform airflow; this is a compromise only and is by no means ideal.



Eccentric flow conditions at both inlet and outlet will result in part of the impeller being starved of air and the fan not operating satisfactorily.

Figure 3: Flexible connection to fan

Flexible connections must be taut or turbulence at the fan inlet, noise level and pressure will all be increased.

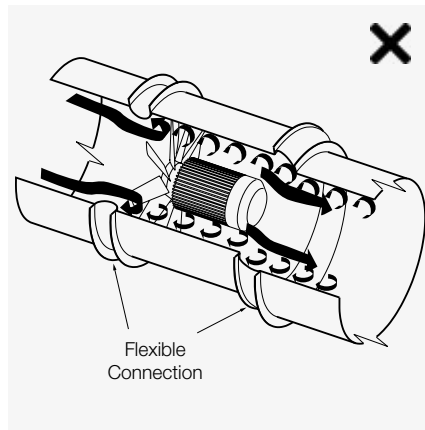
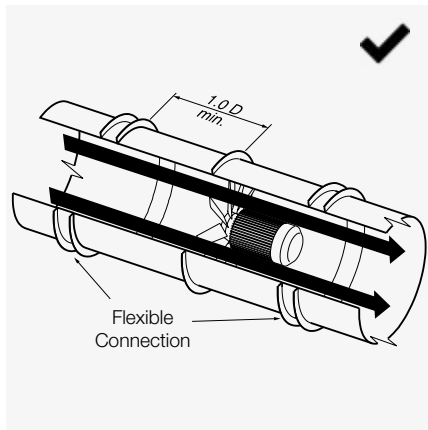

If flexible connectors are fitted they should be remote from the fan and ensure they are taut. The air to the impeller tips is then not obstructed allowing the fan to operate to its optimum with minimal noise generation.

Slack or misaligned flexible connectors reduce the effective duct area. This generates turbulence and the blade tips are starved of air. Fan performance is reduced and noise levels increased.

Figure 4: Duct restrictions at fans

Ducts significantly smaller than the fan diameter create turbulence if transitions connect directly to the fan.

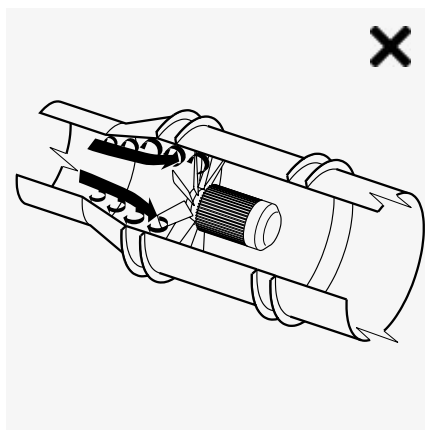
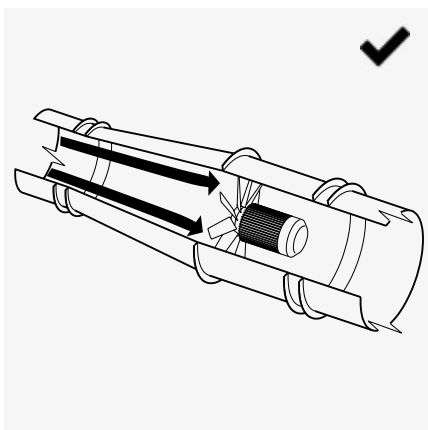

Duct expansion on the inlet to Axial Flow Fans should be avoided where at all possible. If essential the transition should have an included angle of not more than 15°.

An abrupt duct expansion at fan inlet causes air separation from the duct, starves the impeller tips, creates turbulence, reduces performance and generates increased noise.

Figure 5: Pressure recovery

Look for opportunities for pressure recovery at axial exhaust fan outlets.

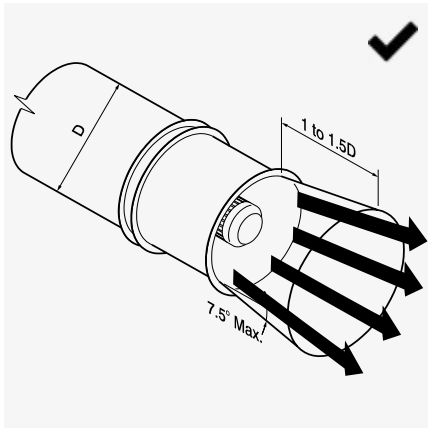

With a correctly designed discharge diffuser the pressure recovery in the diffuser will reduce the system total pressure. Included angle of diffuser to be 15° or less. This arrangement substantially reduces discharge losses.

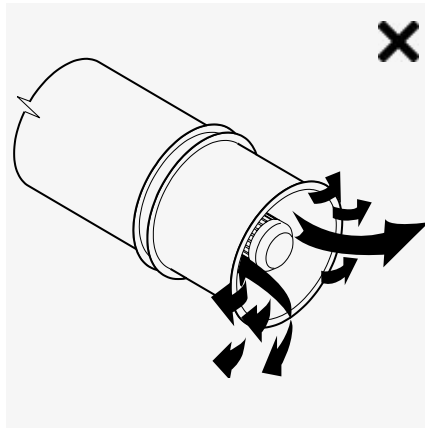

To determine the system resistance the discharge losses have to be added before selecting the fan. Discharge losses are highest in this arrangement and are equivalent to one velocity head.

Figure 6: Obstructions at fan outlet

Don't obstruct fan outlet.

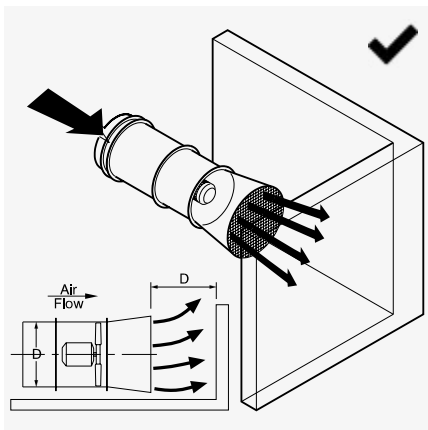

Allow a gap of at least one fan diameter between fan outlet and obstruction and fit a diffuser on the discharge.

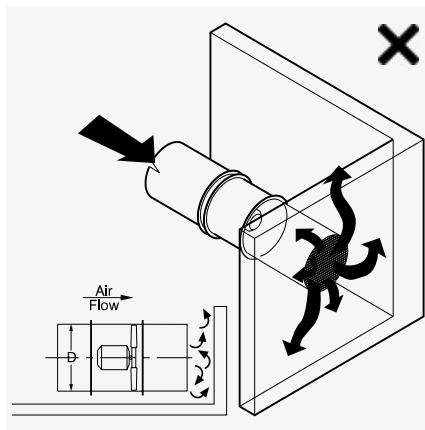

When the discharge is too close to a wall the obstruction generates noise and increases discharge losses.

Figure 7: Obstruction at fan inlets

Don't obstruct fan inlets.

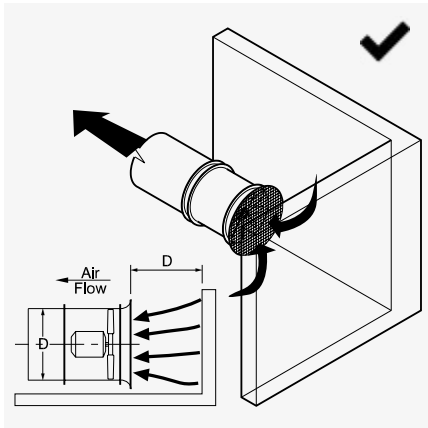

Allow a gap at least equal to one fan diameter between the fan intake and nearby obstructions, even then fan performance can be less than rated. Always fit an inlet cone on open Axial Fan inlets.

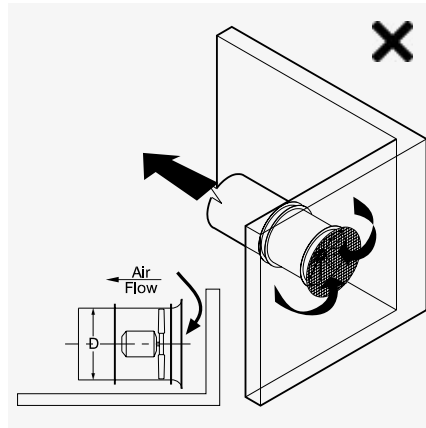

The impeller can be starved of air when the inlet to the fan is obstructed. This effectively increases the system resistance thereby reducing the air flow being handled by the fan. This applies to all fan types.

Figure 8: Guards

Safety of personnel around rotating machinery is crucial.

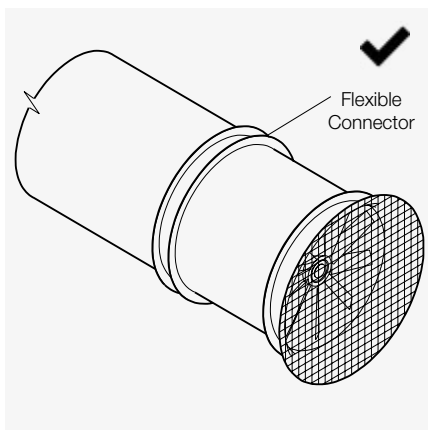

Ensure open fan inlets are fitted with suitable guards. These should be designed to comply with local regulations and not only protect against injury but lessen the risk of a foreign object entering the fan and causing damage.

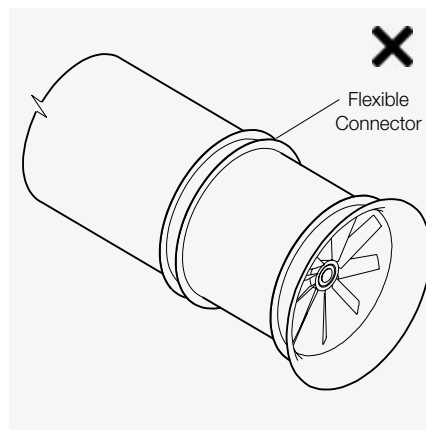

Don't leave open fan inlets unguarded. This is unsafe to personnel and machinery. In addition it may be illegal and leave the building owner or installer open to prosecution.

CENTRIFUGAL FANS

Centrifugal Fans are so called due to the centrifugal nature where energy is imparted on the air and the airflow is radial in direction. These fans typically provide higher pressure development than Axial Fans. The two main types of centrifugal are forward curved and backward curved.

Figure 9: Pressure recovery

Look for opportunities for pressure recovery at centrifugal exhaust fan outlets.

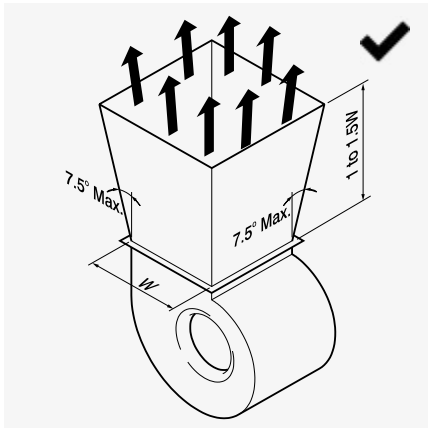

With a correctly designed discharge diffuser the pressure recovery in the diffuser will reduce the total system pressure. Included angle of diffuser to be 15° or less. Discharge losses reduced by up to 75% in this arrangement.

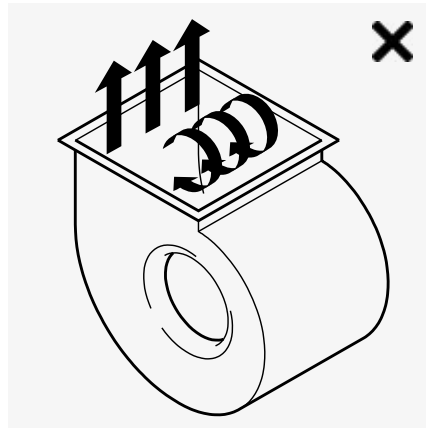

To determine the system resistance the discharge losses have to be added before selecting the fan. Discharge losses are highest in this arrangement and are equivalent to one velocity head.

Figure 10: Bend on fan discharge

Bends near fan discharge should be in direction of wheel rotation to prevent needless pressure loss.

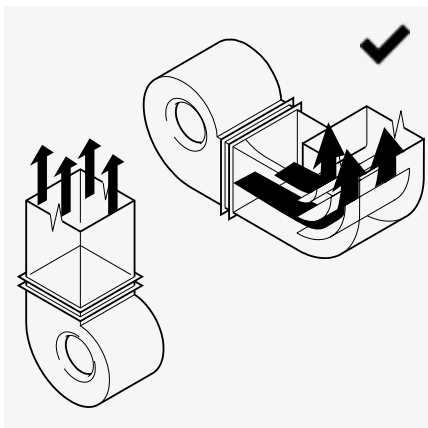

Improved discharge arrangement with radiused bends and splitters or different fan mounting position will reduce system losses. Bends should 'rotate' in the same direction as the impeller.

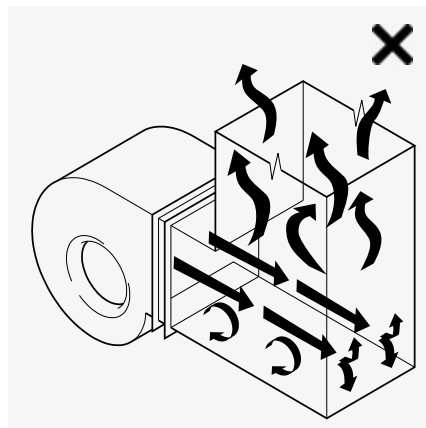

Air moves faster at the outside of the fan housing and is not evened out before striking the abrupt bend. This results in a very high pressure loss.

Figure 11: Spinning of air at inlet connection

Ensure spinning of air at fan inlet does not take place.

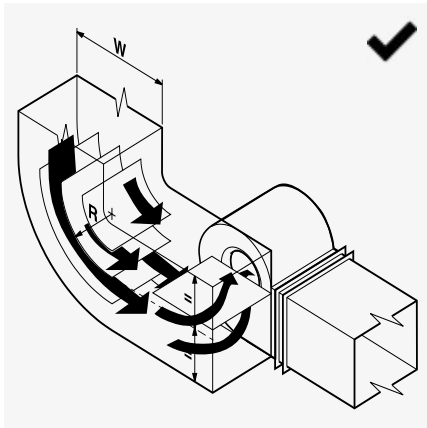

Splitters at the inlet help prevent spinning flow. Turning vanes, where $R/W < 1.0$ improves uniformity of flow approaching the fan inlet. Inlet boxes should be amply sized.

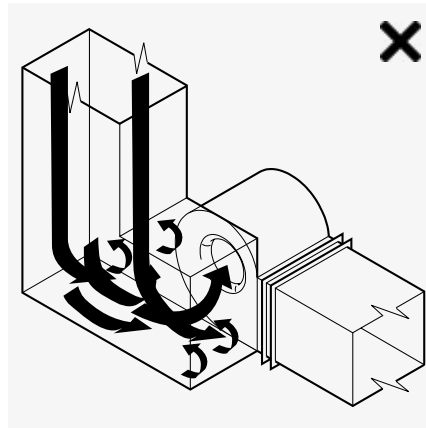

A poorly designed inlet box can generate spinning of the air which can reduce performance by around 25%. Make sure to avoid small inlet boxes as they can cause surging.

Figure 12: Eccentric inlet flow

Do ensure inlet air to the fan is evenly distributed.

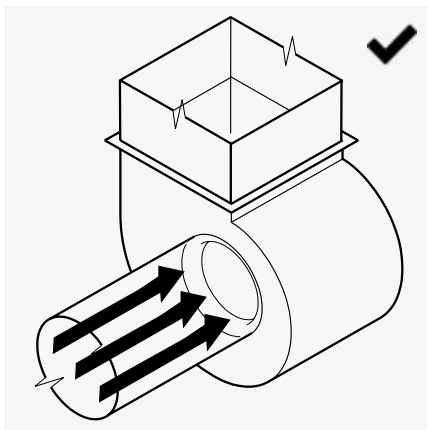

Rated fan performance is only achieved when air flows evenly into the fan impeller.

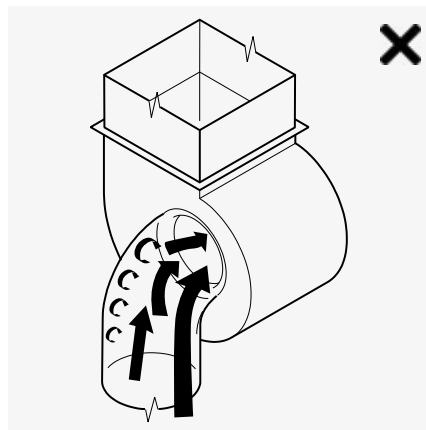

Eccentric air distribution at fan inlet diminishes fan performance by up to 45% because the main flow is accelerated through an effectively smaller duct area on one side while turbulence and high intensity pressure fluctuations occur on the other. Noise level is also increased.

ROOF FANS

Roof Fans are specifically designed to offer ventilation through roof outlets. The range includes models designed to offer high levels of volume flow or pressure in axial, centrifugal or mixed flow configuration.

Figure 13: Roof ventilator short-circuiting of air

Ensure the roof ventilator base has an airtight seal.

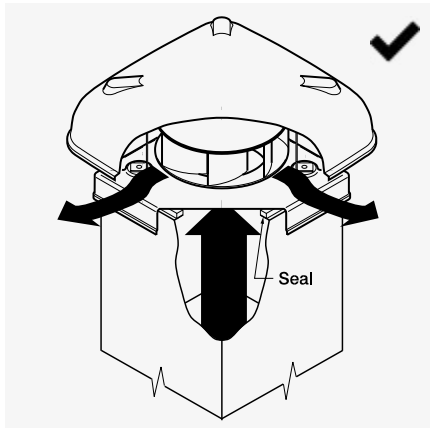

An airtight seal between the upstand and the fan base prevents short-circuiting of outside air ensuring the fan is exhausting from the designated space.

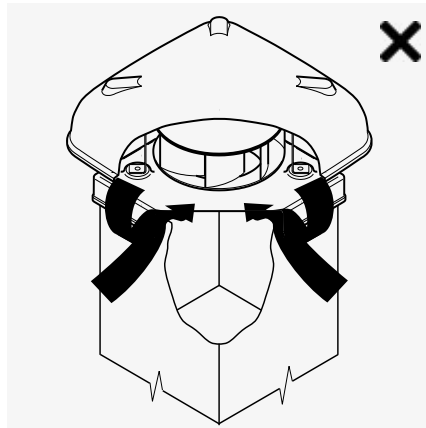

If the unit does not have an airtight seal between the base and the upstand, short-circuiting of outside air can occur thereby reducing the amount exhausted from the building.

Figure 14: Maximum mounting angle for roof units

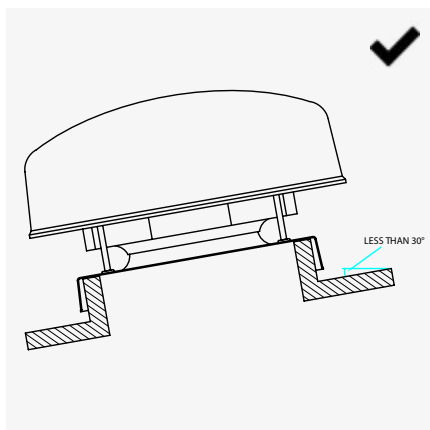

Do ensure the upstand, and therefore fan, is at an angle less than 30°. Some fans may require an angle less than 30° or a completely horizontal upstand - refer to the relevant product page.

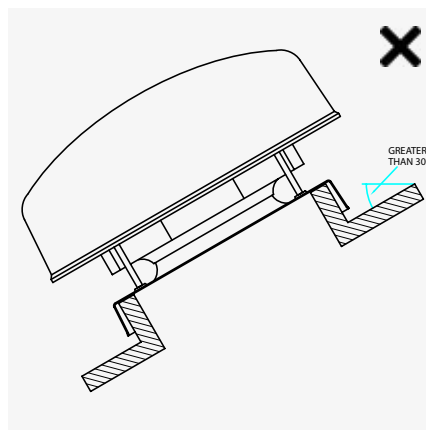

Don't mount the fan on an upstand or curb with an angle greater than 30°.

Figure 15: Backdraught shutters

Butterfly backdraught shutters on a roof unit should be installed so that the gravitational effect on each leaf is the same.

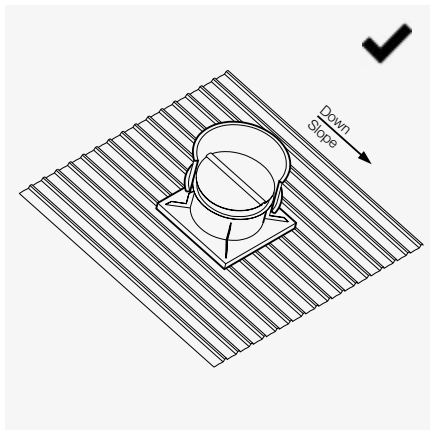

Each leaf has the same gravitational effect when shutters are parallel with roof fall.

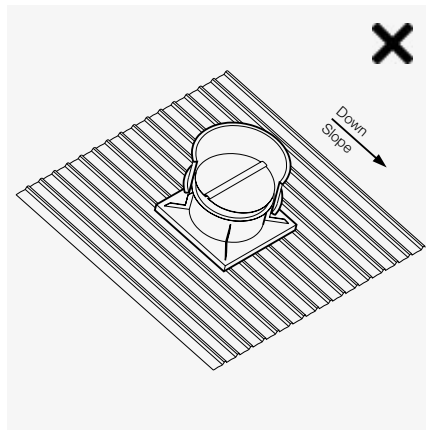

Don't have shutters at 90° to roof fall. The lower shutter must overcome a greater gravitational effect to even airflow and the top damper may go over top dead centre and not close.

Figure 16: Prevailing winds

Mechanical roof ventilator units perform best if influence of prevailing wind is minimal.

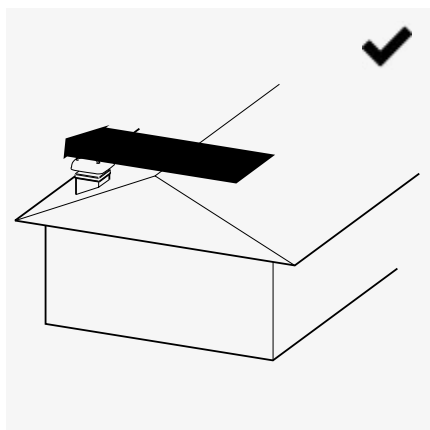

Roof units relatively sheltered from prevailing winds suffer less from back-pressure effects.

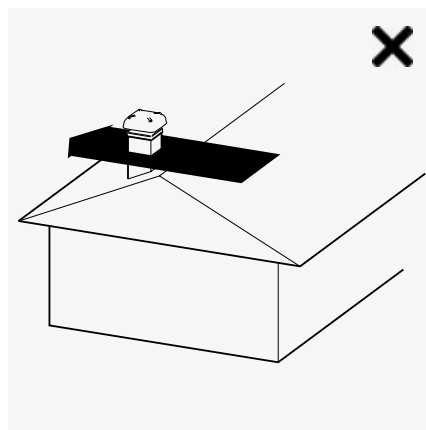

Units that are installed above the ridge are exposed to crosswinds and exhaust capacity may therefore be reduced due to back-pressure effects.

NOISE CONTROL

All fans that move air, generate pressure and absorb power will create sound. Sound cannot be avoided but it can be minimised or reduced. When a fan is poorly installed, or the system is badly designed, an unwanted noise is created. Airborne and duct-borne noise can be reduced by using attenuators and structure-borne noise can be reduced by isolating the fan from the structure and duct. Using lined fan types and duct lining can also alleviate breakout of duct-borne noise.

Figure 17: Transitions

Ensure symmetrical transitions from the duct equipment to fan inlet.

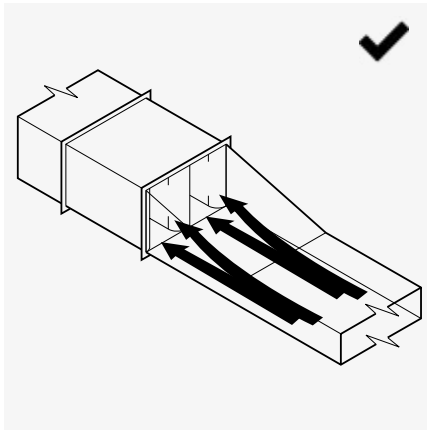

Ensure transitions close to attenuators are gradual or, preferably, remote.

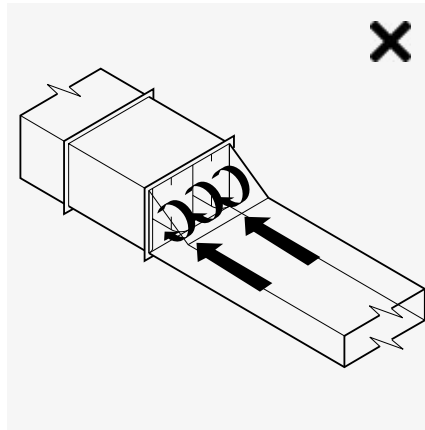

Abrupt transitions immediately adjacent to an attenuator will cause the attenuator pressure to increase.

Figure 18: Volume Control Dampers

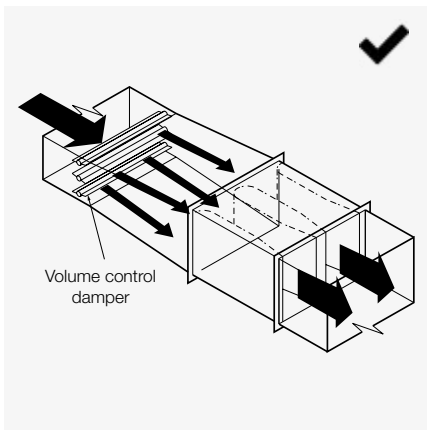

Allow for a settling duct between volume control dampers and attenuators.

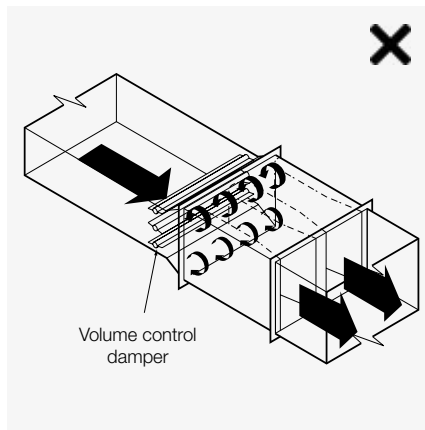

Don't site volume control dampers or fittings too close to attenuators as they can cause a dramatic increase in attenuator pressure drop.

Figure 19: Attenuators in relation to bends

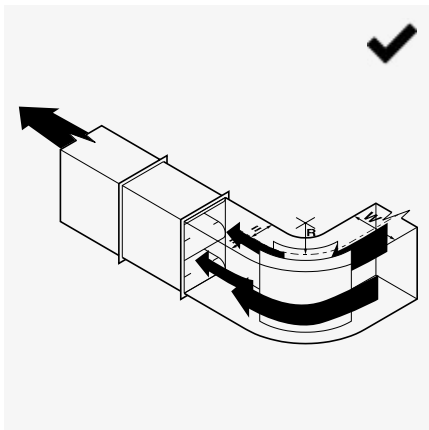

Do ensure attenuator splitters are in the plane of the bend as shown. Fit turning vanes if $R/W < 1.0$.

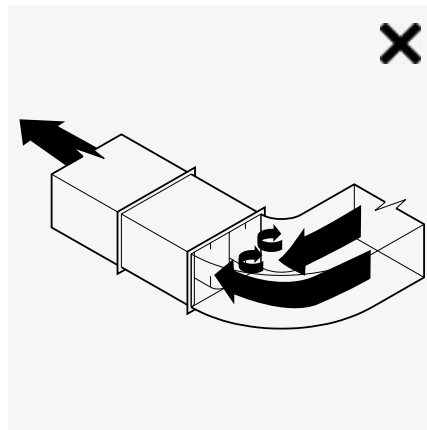

Don't use attenuator splitters as shown when sited close to a bend as the pressure loss across it will be greater than expected.

Figure 20: Attenuator position relative to Axial Fans

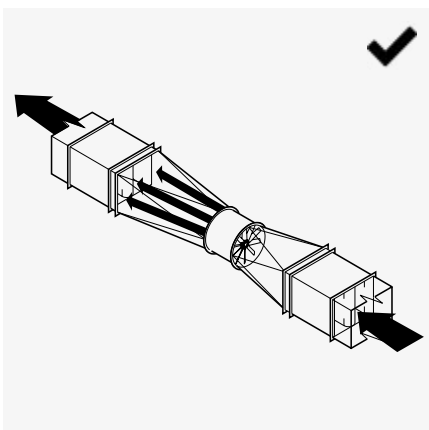

Do allow adequate distance between attenuators and fan.

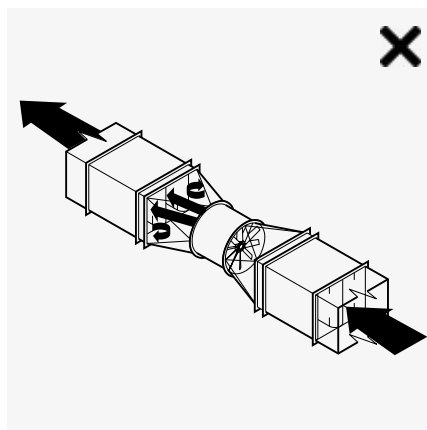

Don't site a rectangular attenuator close to an Axial Fan intake or discharge. Air is accelerated through an attenuator and fan discharge air is uneven and swirling.

Figure 21: Attenuator position relative to Axial Fans

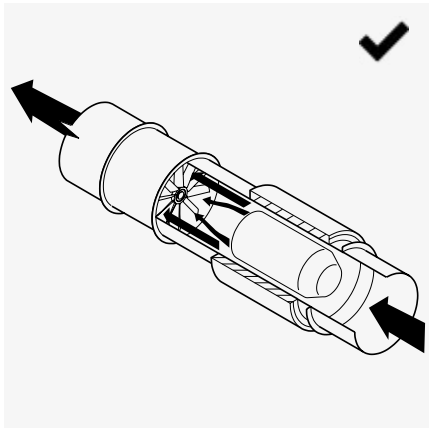

Do allow one diameter of straight duct between pod attenuator and the fan inlet to ensure impeller obtains an even flow of air.

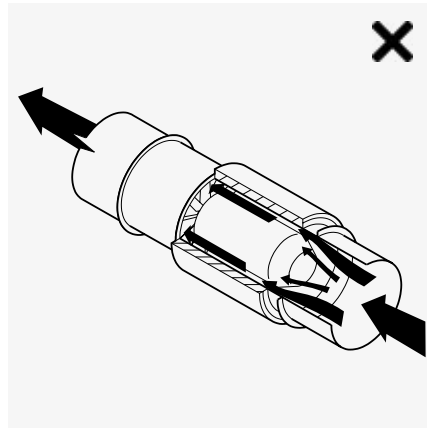

Don't site pod attenuators immediately upstream of the fan as the attenuator pod will block the airflow to fan impeller. However, if the pod is the same size or smaller than the impeller hub bolting directly to the fan is acceptable.

Figure 22: Attenuator position relative to centrifugal fans

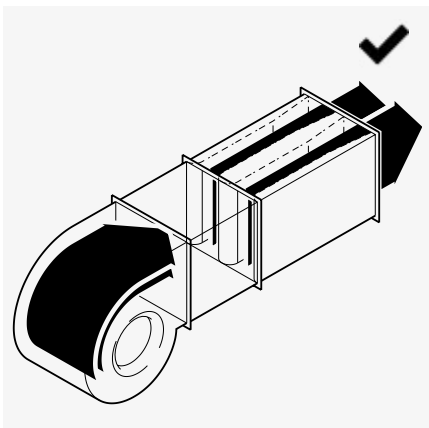

Do place a spacer between the fan and the attenuator, and rotate the splitter orientation by 90°

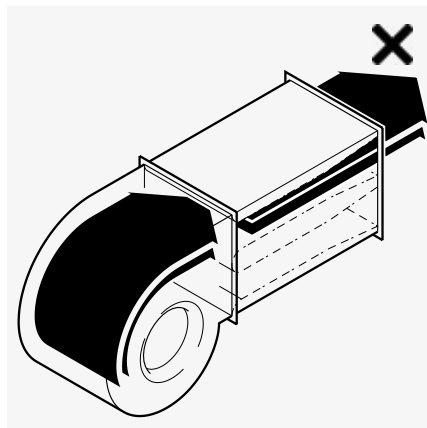

Don't place a rectangular attenuator hard against the discharge of a Centrifugal Fan. Note: the splitter orientation.

Figure 23: Acoustic sealing of silencers to achieve low noise levels



Do place a concrete sleeve around the silencer to increase the acoustic seal between rooms. For less stringent requirements, pack around the silencer with a resilient material to affect a complete seal between the attenuator and the opening.

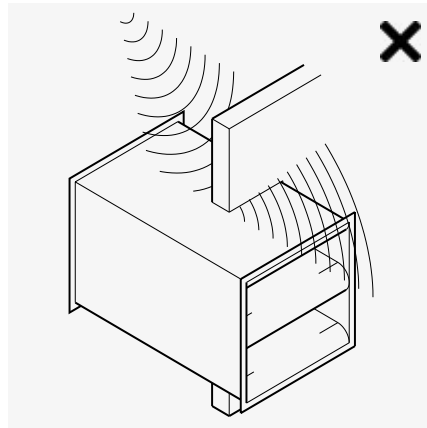

Don't use an inadequate seal between the silencer and the wall opening when trying to achieve very high attenuation or very low noise levels (e.g. NR20).

Figure 24: Isolated walls

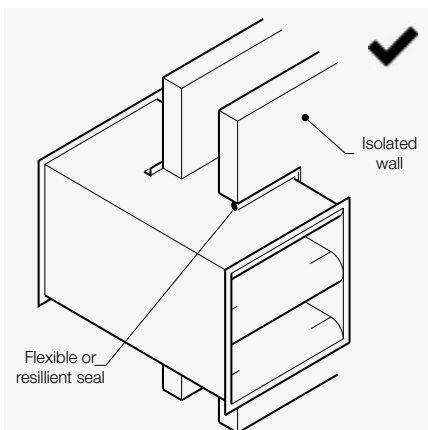

Do fix the silencer to one wall only and place a flexible or resilient seal on the isolated wall.

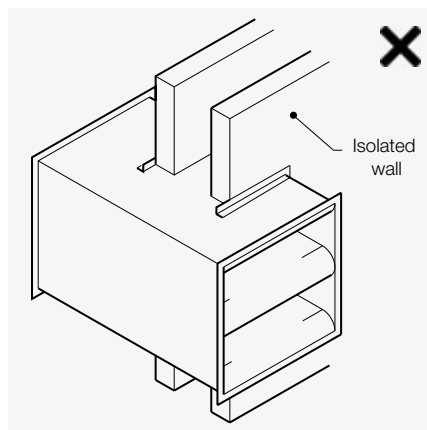

Don't bridge the isolated wall to the non-isolated wall with the silencer fixings.

Figure 25: Louvres on silencer discharge

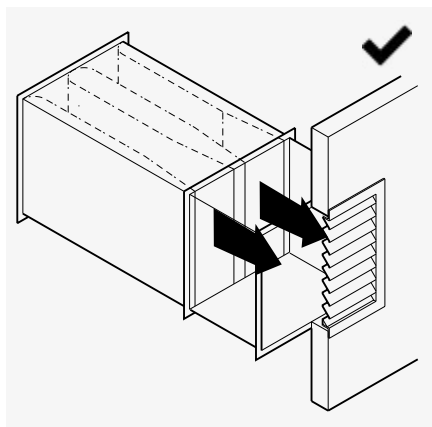

Do ensure that the splitter orientation is at 90° to the louver orientation and place a spacer between the silencer and discharge louver.

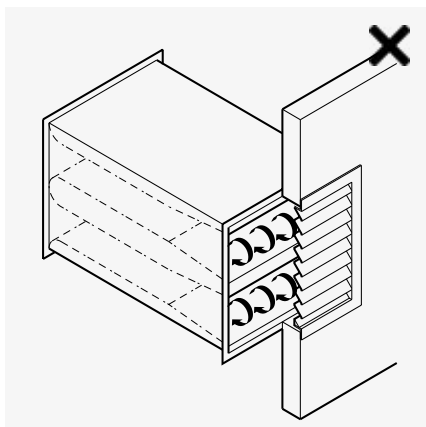

Don't place a silencer immediately in front of a louver.

Figure 26: Louvres on silencer inlet

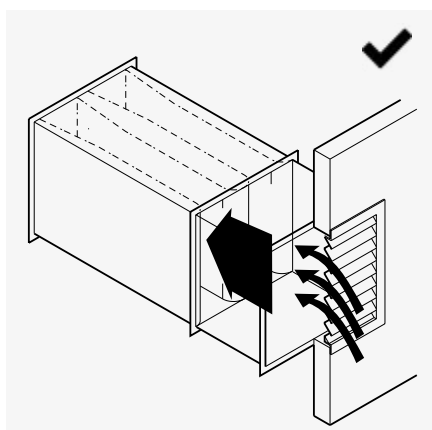

Do place a spacer between the louver and the silencer and ensure that the splitter orientation is at 90° to the louver orientation.

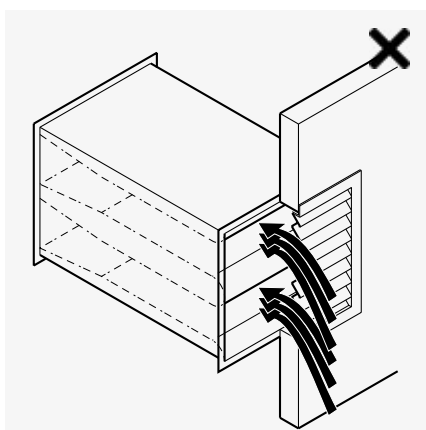

Don't place a silencer immediately downstream of a louver.

Figure 27: Fan positions relative to noise sensitive areas

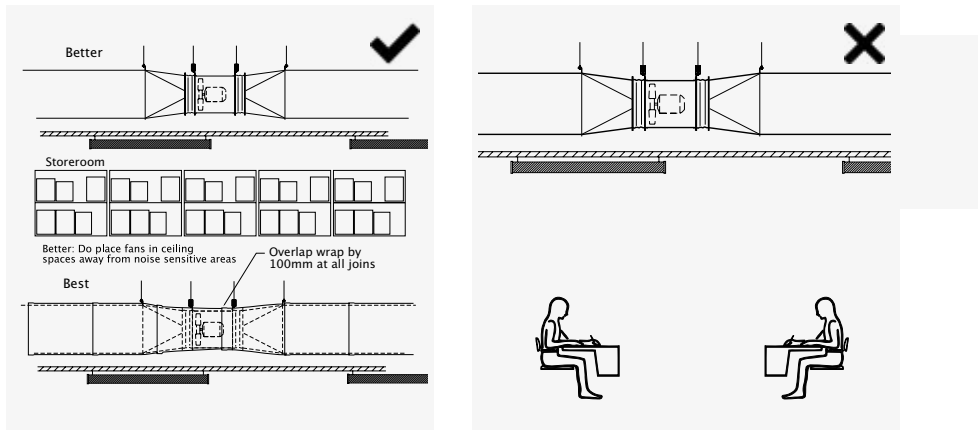

If a fan cannot be relocated, wrap the fan and surrounding ductwork with a noise barrier material (when wrapping fans pay particular attention to ensuring there are no holes at the joints). Allow sufficient overlap in the wrap to ensure adequate coverage. Remember that flexible connections will be the weakest link.

Do not place fans in ceiling spaces directly above noise sensitive areas.

Figure 28: Flanking transmission

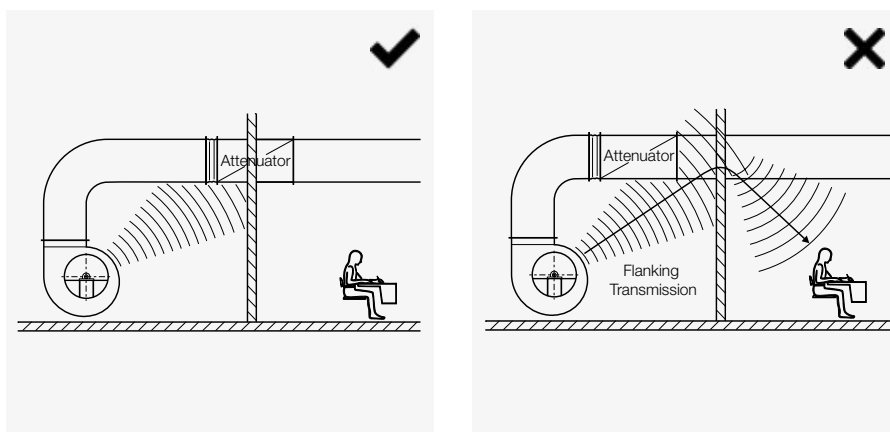

Do install the attenuator through or against a wall to minimise the chance of flanking transmission via the duct system, ensuring the expected performance is achieved.

Do not install the attenuator as shown, as noise from the fan can bypass the attenuator and enter the conditioned space. This is known as flanking transmission and will negatively impact on the expected attenuator performance.

Figure 29: Airflow generated noise from silencers

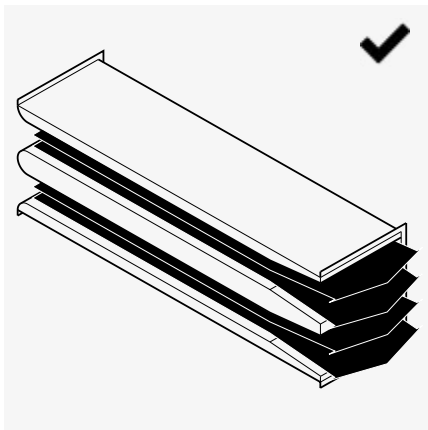

Do check silencer airflow generated noise levels when these conditions occur. If airflow generated noise is too high, try using a longer silencer with a larger open area to get the same attenuation at a lesser airflow generated noise, or acoustically treat the duct after the silencer.



Don't select a silencer with high attenuation and low percentage open area without checking the airflow generated noise level.

Figure 30: Changing direction of airflow

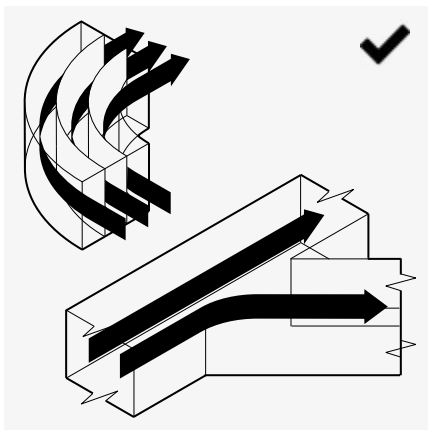

Do use sweeping bends and takeoffs. Use long chord turning vanes where possible. Keep velocities low to reduce airflow generated noise levels.

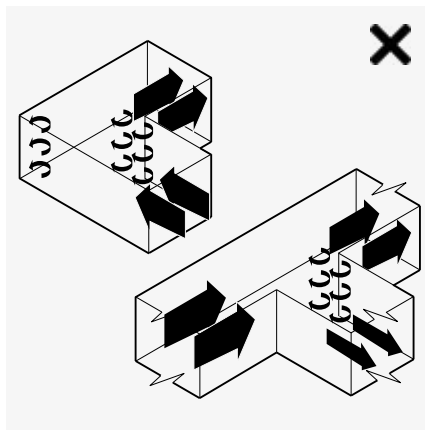

Don't use sharp bends or takeoffs.

Figure 31: Reduction of external noise generated from roof units

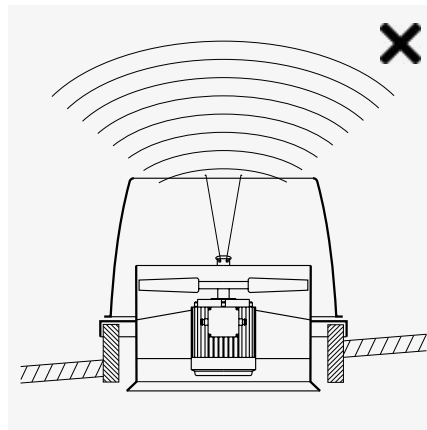
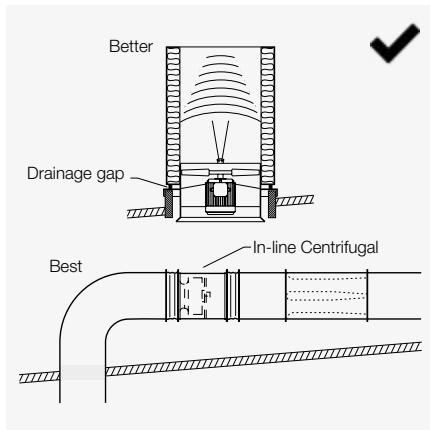

Do change to an inline fan running parallel to the roof, and place a rectangular silencer on the outdoor side. Direct the duct opening away from noise sensitive areas.

When a quieter fan is not possible to select, generated external background noise can be a problem at the outlet of the fan.
Caution: No acoustic treatment.

Figure 32: Reduction of internal noise from non-ducted roof units

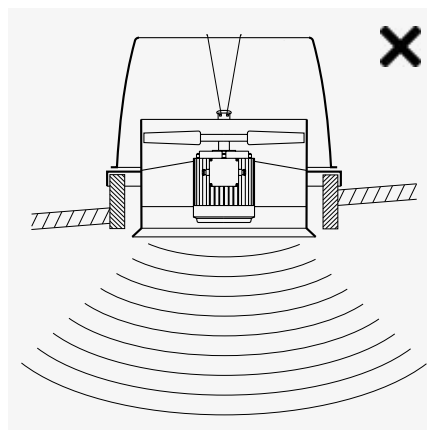
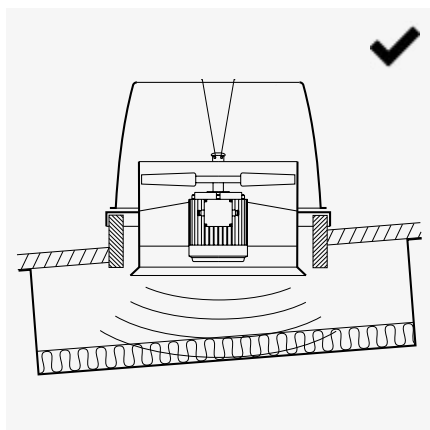

Do place an acoustic baffle below the fan inlet / discharge to limit internal background noise.

When a quieter fan is not possible to select, generated internal background noise can be a problem at the outlet of the fan.
Caution: No acoustic treatment.

Figure 33: When noise generated by grilles could cause a problem

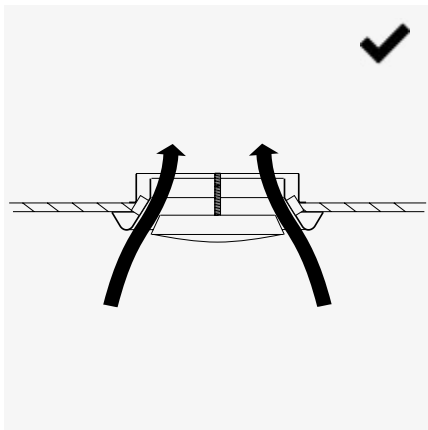

Do ensure velocities through supply and exhaust grilles are low by increasing the grille size or number of grilles. Size the ductwork for constant static pressure to each grille, thus eliminating or minimising the need for balancing damper adjustment (which can generate excessive noise).

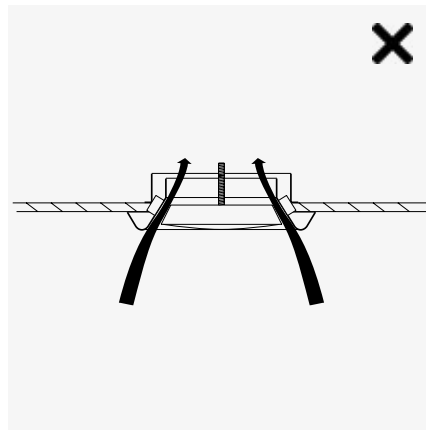

Don't allow high velocity air to pass through grilles.

VIBRATION ISOLATION

A fan will inevitably vibrate, this will cause vibration through the structure it is mounted to. To overcome this, vibration isolators are offered. These should be selected to offer the minimum deflection required and be suitable for the fan and its environment where it will be operating. Flexible duct connectors are also available to aid in the reduction of both noise and vibration.

Figure 34: Isolating vibrating fans

Vibration transmission through building structures is a frequent problem.

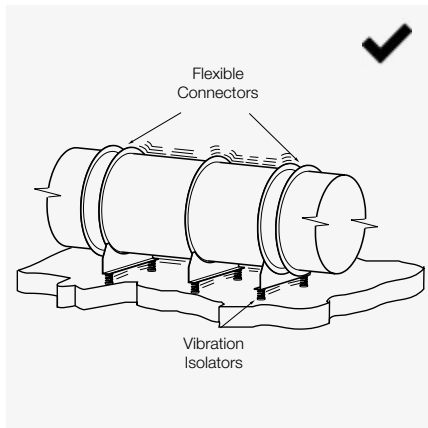

Do isolate fan and duct from the building structure with fan on neoprene or spring isolators and suitable flexible connectors.

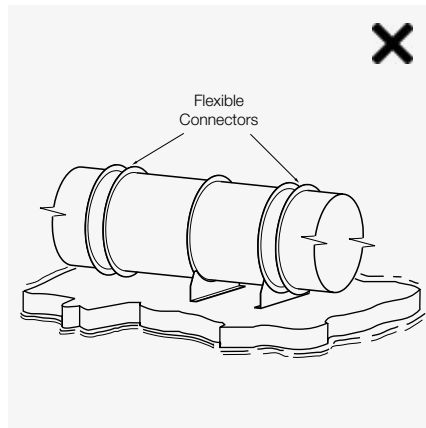

Don't bolt the fan directly to the building structure as noise and vibration can be transmitted directly to the building fabric.

Figure 35: Isolation of roof mounting fans

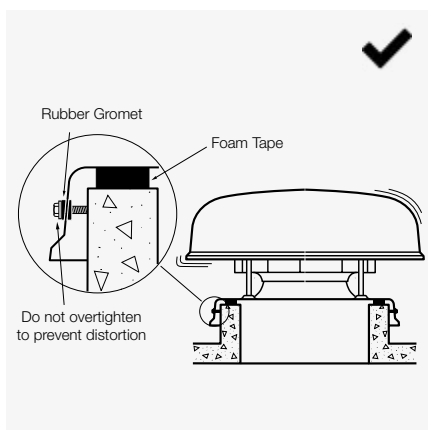

Do isolate roof mounted fans from the duct work and upstand by using a foam tape between the top of the upstand and the fan. Where the fan is fixed to the upstand with bolt and screws use rubber / neoprene grommets.

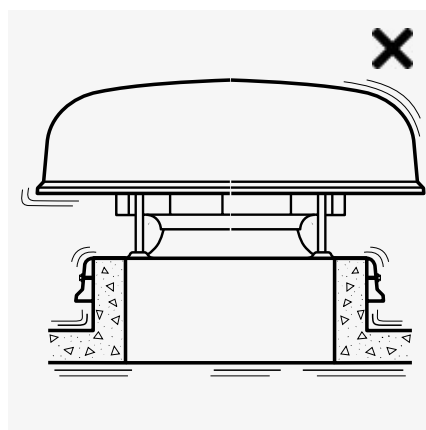

Don't hard mount roof mounted fans to upstands.

Figure 36: Correct sizing of spring mounts

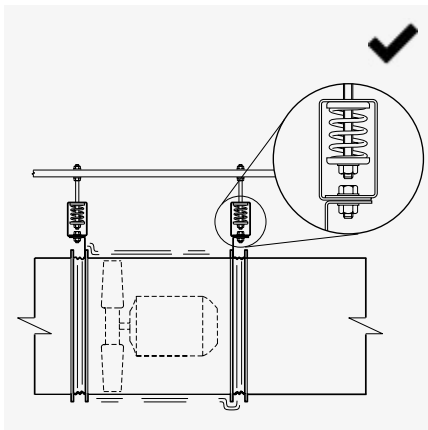

Do ensure that spring mounts are sized correctly for the job. Be careful to include the weight of ductwork (and any other piece of equipment) if they are going to be supported by the vibration isolators. Also ensure spring mounts incorporate neoprene or rubber pads to eliminate noise which can travel through a steel spring.

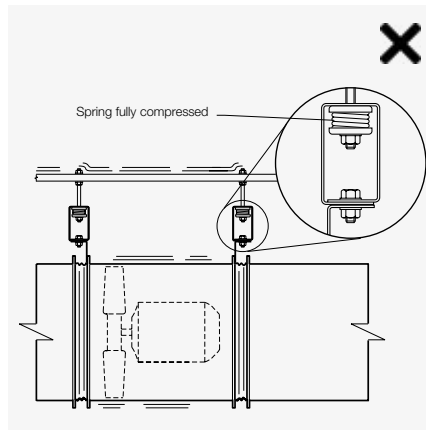

Don't overload spring mounts.

Figure 37: Short circuiting of vibration mounts

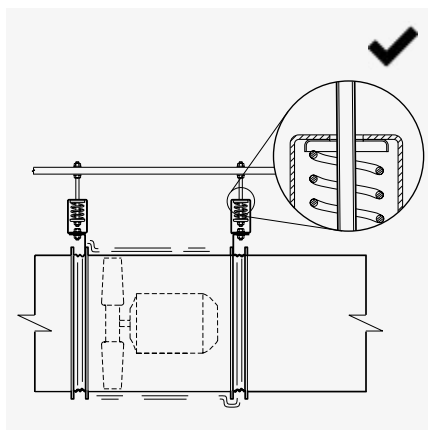

Do ensure vibration mounts are free from short circuiting by making sure that the hanger rods are central and not in contact with the hanger cage. Ensure no debris, or other connection is creating another path through which the vibration could transmit.

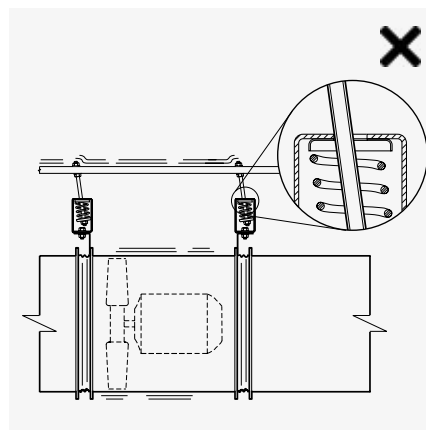

Don't allow short circuiting of vibration mounts.

Figure 38: Transitions

Ensure symmetrical transitions from the duct equipment to fan inlet.

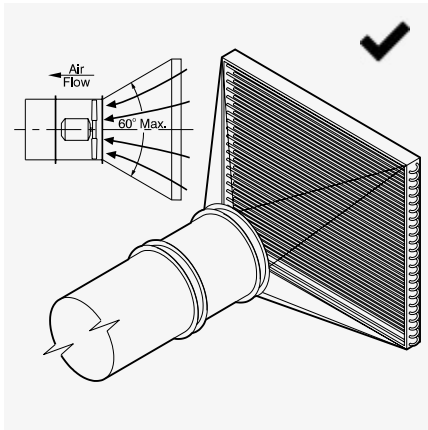

Do centralise the fan to ensure uniform airflow through the coil.

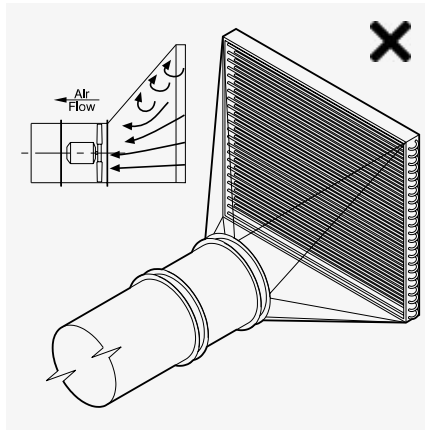

Do not install the fan off-centre as this will result in little or no airflow through the top of the coil.

Figure 39: Airflow dead zones

Unducted air extract fans require careful location to obtain an even airflow across the room.

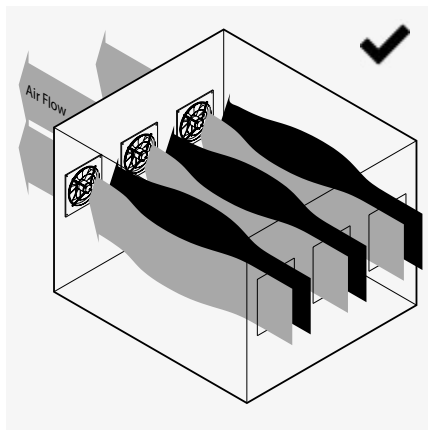

Do ensure cross-flow ventilation so that air circulation and the quality of ventilation is optimised.

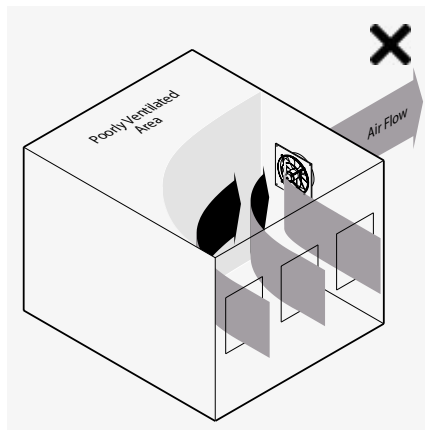

Do not leave rooms vulnerable to dead zones where areas are starved of ventilated air.

Figure 40: Inlet plenums

Ensure eccentric flow is not caused by inlet plenum.

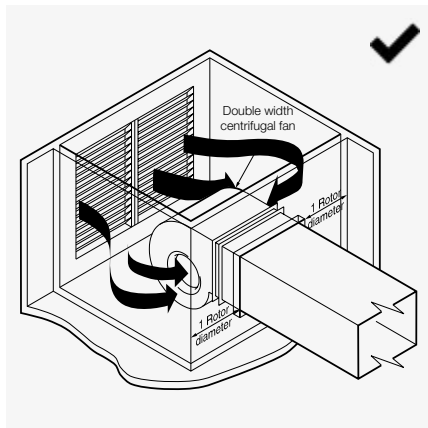

Do select a double inlet fan to improve airflow. Central positioning of the fan and plenum entry grille will also assist.

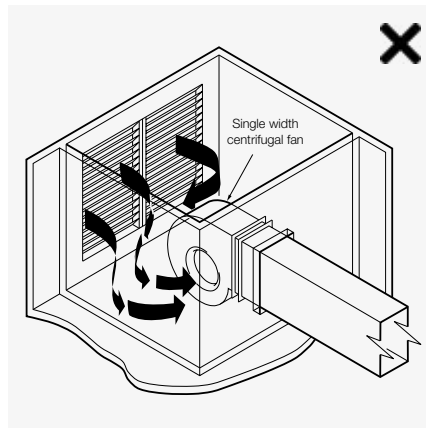

Do not select a single width fan as the airflow takes a single turn to enter it and eccentric flow is created.

Figure 41: The correct fan for the application

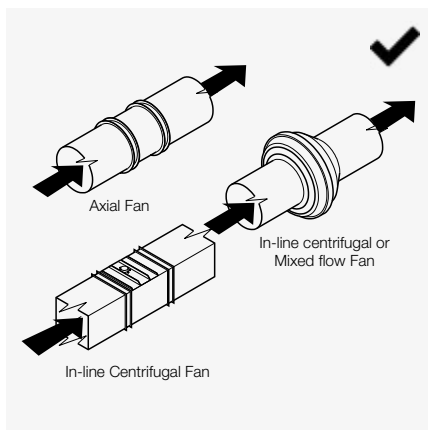

Do consider the space saving advantages of an inline fan. It can be centrifugal, mixed flow or axial, this selection being governed by the fan duty and noise level required.

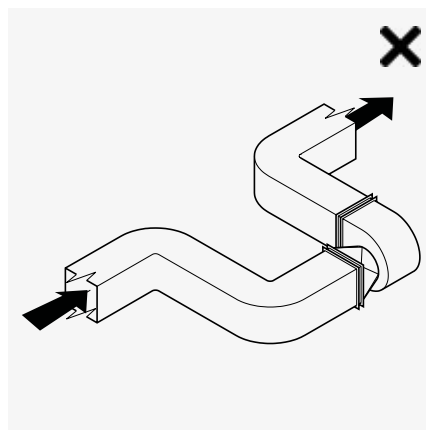

Don't use a centrifugal blower if space is at a premium and avoid unnecessary bends.

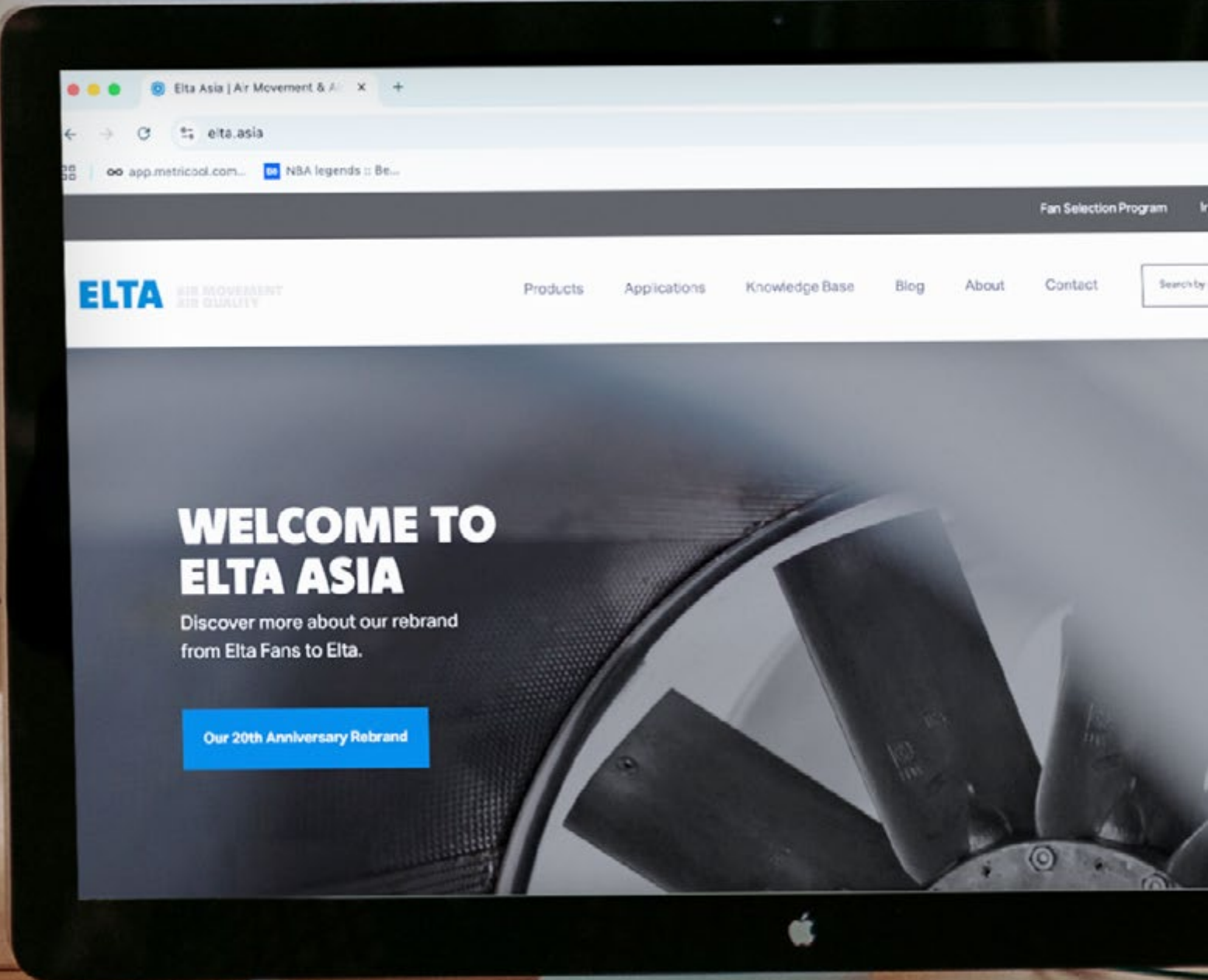

Visit the downloads page on our website at elta.asia to download the full installation & maintenance manual for your product.

