



CF SERIES

Compact Axial Fan

CF SERIES



Description

The CF Series of compact axial fans is designed for use in applications ranging from computer equipment cooling to the ventilation of light boxes and switchboards.

For specific applications, sizes other than those shown are available on request.

Typical Applications

Designed to ventilate and cool equipment such as computers, light boxes and switchboards.

Features

- Compact and robust construction.
- High performance with low noise levels.
- Electrophorescent baked enamel finish on surfaces subject to corrosion.
- Can be mounted at any angle.

Construction

The fan housings are made of pressure die-cast aluminium, resulting in a robust and durable product. All surfaces subject to corrosion have an electrophorescent baked enamel finish which is resistant to impact and abrasion.

Motor

Type - external rotor shaded pole motor.
 Electrical supply - 230V, single-phase, 50Hz.
 Ball Bearing - sealed for life.
 These fans are not speed-controllable.
 Class A insulation

Internal Thermal Protection

Impedance protected.

Testing

Airflow testing Model CF112: DIN 24 163
 Model CF132: AMCA A210/85

Noise Testing

Model CF112: ISO 3745
 Model CF132: ISO 3744:2010

Suggested Specification

The fans shall be of the CF series as supplied by Elta Fans
 Housings shall be of injection-moulded aluminium with a corrosion resistant finish.

Model CF112 shall be fully tested to DIN 24 163 for airflow and ISO 3745 for noise.

Model CF132 shall be fully tested to AMCA A210/85 for airflow and ISO 3744:2010 for noise.

Ancillary Equipment



FG - Finger Guards
 Ref. Section J-9

How To Order

Select the fan that exhausts the closest to your requirements. If the performance falls between the two models, select the fan that handles the most air.

Technical Data

Model Number	Fan Speed CF.. rev/sec	Avg. dB(A) @ 1m	CF.. 1 ph. Watts	Amps	Max. °C
112	55	42	4.4	0.05	75
132	46	50	46	0.30	70

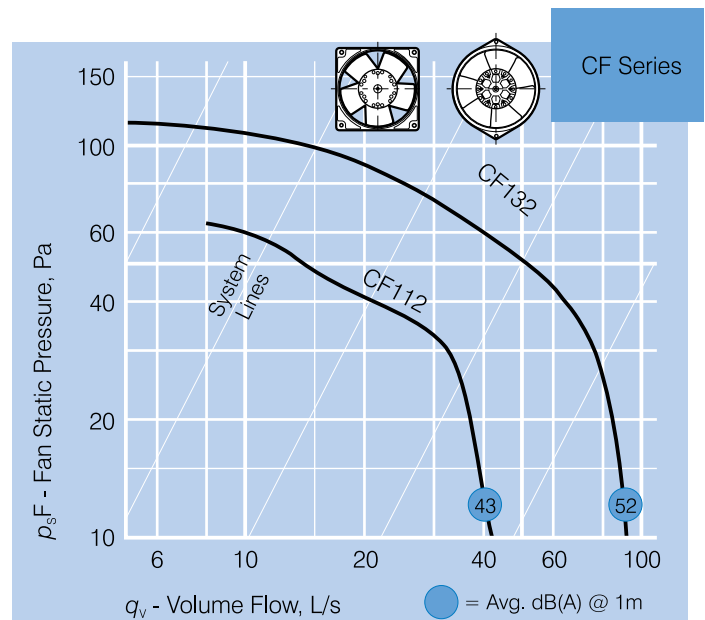

Dimensions

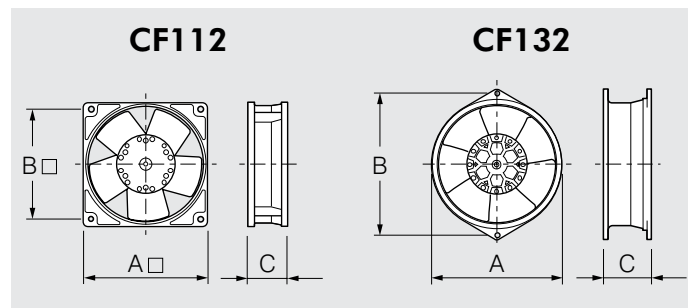

Model Number	Dimensions, mm	Approx. weight kg.
CF..	A □ B □ C	
112	119 119 38	0.25
132	150 162 55	1.20

Elta Fans Malaysia Sdn Bhd

Tel **+603 7846 0340**

Fax **+603 7842 1132**

Email **info@eltafans.asia**

No. 147, Jalan TUDM Kampung
Baru Subang, 40150 Shah Alam,
Selangor West Malaysia, Malaysia

eltafans.asia

CF-08-2019 Issue A



FS 676456