

# hydor

# Hi-Flow Wall Circulation Fan



90°  
turning arc

3  
speed

The large Hi-Flow Wall air circulation fans are designed for use in a wide variety of agriculture and horticulture applications.

Wall mounted units are highly suitable for mounting in milking parlours, holding areas and calf housing. Whether it is for your dairy herd or staff, Hydor wall mounted fans provide powerful, cool, yet effective, positive air movement, thereby improving the environmental conditions for both humans and animals.

## Features & Benefits

- Control of insects in the summer months – many insects and flies are discouraged by the constant airflow created by the circulating fans
- Provides a reduction in livestock heat stress, thereby reducing veterinary expenses
- Air circulation results in improved root growth and a healthier plant in horticulture applications
- Air circulation moves fumes away from animals, circulating gases to a higher level for extraction at roof level
- Wall mounted fan reduces trip hazards
- 3 speed settings
- Black meshed guard for protection

# Hi-Flow Wall Circulation Fan

Model	Speed (r/min)	Airflow (m <sup>3</sup> /s)	Power (W)	FLC (Amps)	dBA @ 3m	Maximum Tilt
HWFA650 Low	890	1.83	130	0.56	46	30°
HWFA650 Med	1050	2.83	140	0.62	50	30°
HWFA650 High	1380	3.83	170	0.80	59	30°

## Dimensions

Model	A	B	C	D	E	F	G	H	J	K	L	Weight (kg)
HWFA	190	114	12.5	112	690	445	30°	360	525	590	90°	14.3

Dimensions in mm.

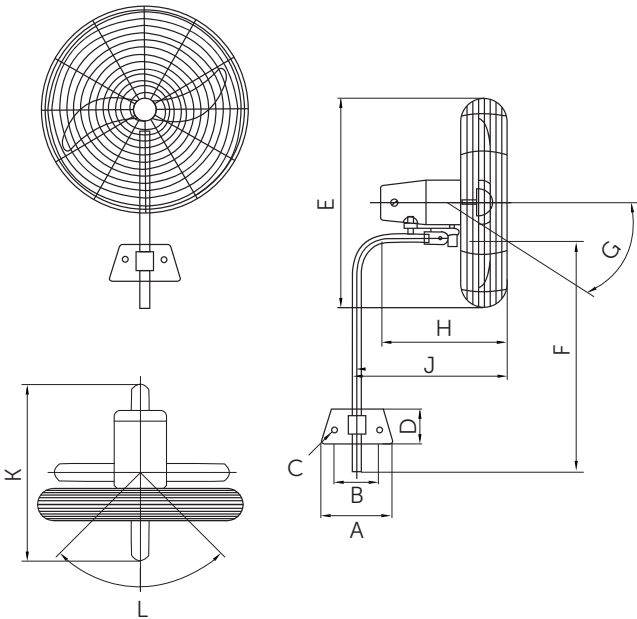

ISSUE 3. SEP.2019.