

Agri-Max Tube Fan

Installation and Maintenance Instructions.

THESE INSTRUCTIONS MUST BE READ FULLY BEFORE COMMENCING INSTALLATION.

Owner / installer: The life of this apparatus and its efficiency will be increased if its use and maintenance is carried out in accordance with these instructions and current statutory requirements. The installation and initial adjustments should be carried out by a qualified and competent technician. Hydor Limited should be consulted before substituting or fitting parts from another manufacturer. It is the responsibility of the installer to verify that the installation is in accordance with all current statutory requirements and the owner is given the current User's Manual.

Any modifications to the fan or its installation, even the smallest modification, change or elimination of security components or pieces that influence the efficiency or loss of ventilation, will result in the CE Certification and Hydor's warranty being cancelled.

Please take note of the following symbols used within this document:



Warning: Hazards associated with electric current and high voltages



Important: Important information

Hydor's policy is one of continual improvement and the right to change a specification at any time without notice is reserved. Whilst every care has been taken to ensure that the contents of this document are correct at time of publication, Hydor shall be under no liability whatsoever in respect of such contents.

Hydor cannot guarantee the operation of any equipment unless all documented instructions are complied with, without variation.

Hydor is a registered trademark of EG Agri Ltd and is a member of Elta Group. All other trademarks, trade names or company names referenced herein are the property of their respective owners.

1. General

- 1.1 It is important these Installation and Maintenance Instructions are fully adhered to.
- 1.2 Full details of the unit supplied are shown on the product nameplate. If in doubt about any detail contact Hydor or its agents for clarification.
- 1.3 All electrical installation must be carried out by suitably qualified and competent personnel in accordance with all current statutory requirements.
- 1.4 These instructions cover only the Hydor product and do not include the supply or installation of any safety equipment that may be required e.g. adequate guarding or protection from rotating parts and proper electrical isolation.
- 1.5 Any declarations made by Hydor about product installation and safety, are dependant on the fan equipment being used within installations which themselves meet the requirements of the relevant Standards and Directives of your region.
- 1.6 The fan is designed for use in an ambient temperature of up to 70°C (fixed speed), 55°C (speed controlled) and up to 95% relative humidity (non-condensing). The fan is not suitable for corrosive or explosive atmospheres.
- 1.7 The installer should provide easy access to the fan to facilitate future maintenance.
- 1.8 The installer should ensure the fan is adequately supported.
- 1.9 This product is not intended for use by young children or infirm persons unless they have been adequately supervised by a responsible person to ensure that they can use the product safely. Young children should be supervised to ensure that they do not play with the appliance.



WARNING: The fan must be isolated from the power supply during installation and maintenance. The fan must be earthed in accordance with the local regulations.

2. Installation

- 2.1 The Agri-Max range of fans is normally supplied assembled. The single phase units are supplied with the Capacitor loose.
- 2.2 Upon receipt, the fan equipment should be visually inspected to check for any damage. Ensure that the impeller is free to rotate.
- 2.3 If there are any queries concerning the fan equipment, Hydor should be contacted prior to the installation.
- 2.4 The fan must be mounted securely in position.
 - 2.4.1 **Replacement** - Lift the fan sub assembly into place, locating arms in to the Chimney mounting brackets. Tighten arm to bracket fixings. Ensure impeller is centrally located in the chimney and free to rotate.
 - 2.4.2 **New install** - Using the Chimney mounting brackets supplied, mark and drill the Chimney at 90 degree intervals (such that the bottom of the bracket is 130mm from the bottom opening) with 8mm holes to suit two sets of M6 Fixings per bracket. Bolt the Chimney fixings in place, ensuring the M6 Penny washers are on the outside, spreading the weight. Lift the fan sub assembly into place, locating arms into the Chimney mounting brackets. Tighten arm to bracket fixings. Ensure impeller is centrally located in the chimney and free to rotate.

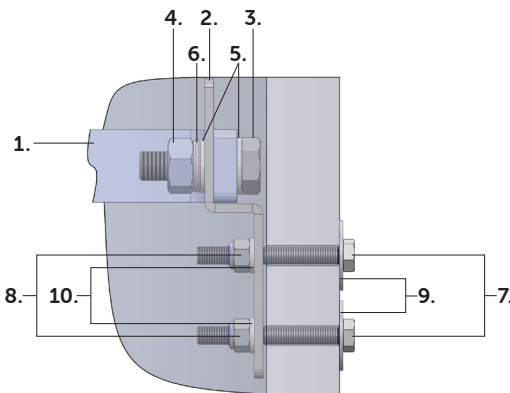
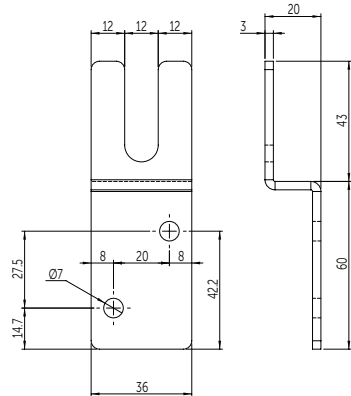
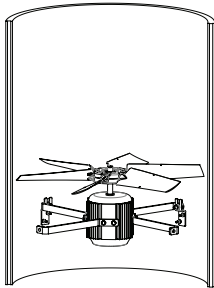

1. Arm-to-bracket
3. 4off M10X40 hexagonal screw
4. 4off M10 full nut
5. 8off M10 flat washer form B
6. 4off M10 single coil washer
2. Bracket to casing/chimney
7. 8off M6x40 hexagonal screw
8. 8off M6 nyloc nut
9. 8off M6 penny washer
10. 8off M6 washer FORM A



IMPORTANT: Do not use the impeller as a lifting or leverage point.

- 2.5 Check the details on the motor rating plate to ensure that the correct power supply (voltage, current, frequency and phase) is available. An incorrect power supply or overload setting will lead to permanent damage to the fan motor.
- 2.6 Refer to the appropriate wiring diagram. Ensure that all earth connections are made.
- 2.7 Means for electrical disconnection must be incorporated in the wiring installation in accordance with the relevant wiring and electrical regulations.
- 2.8 Precaution must be taken to locate the exhaust discharge terminal so as to avoid the backflow of gases into the room from the open flue of gas or other fuel burning appliances.
- 2.9 If the fan is being used through a speed regulation device, either electrically or electronically. Please refer to the relevant control device instructions.

3. Start-up

- 3.1 Before power is supplied to the unit, check that the wiring is correct as per the fan connection diagram.
- 3.2 At initial start-up, check that impeller rotation and airflow direction is correct.
- 3.3 Check that the motor amperage draw does not exceed the nameplate rating.

4. Fan Maintenance

- 4.1 Inspection of the fan at least once every 12 months is recommended to ensure that the motor, fan blades, and supporting guards, are clean. Any build up of dust and deposits on the blades or guards should be removed using a non-abrasive cleaner.
- 4.2 All fastenings should be checked for tightness. In addition, all rotating items should be checked.
- 4.3 Bearings are of the 'sealed for life' type and will not need a detailed inspection.



WARNING: Only a suitably qualified and competent person may carry out maintenance after the electrical supply has been isolated. Particular care must be taken when automatic switching controls are used.

5. Wiring

- 5.1 Check that the fan unit supplied is suitable for the supply voltage and type of fan being replaced.
- 5.2 Remove the terminal plate on the motor which will provide access to the terminal connections. A suitably qualified and competent person should carry out the electrical installation in accordance with the current applicable regulations, in particular IEE 552-01-02/03. Particular attention should be paid to the connections of the capacitor.

NOTE: For motors with Integral connection box. **Single Phase** see 5.3. **Three Phase** see 5.4 on page 6. For **motors with flying leads with external terminal box**, see 5.5 on page 7 and 5.6 on page 8.

5.3 Single Phase

FORM "A" AIRFLOW MODELS

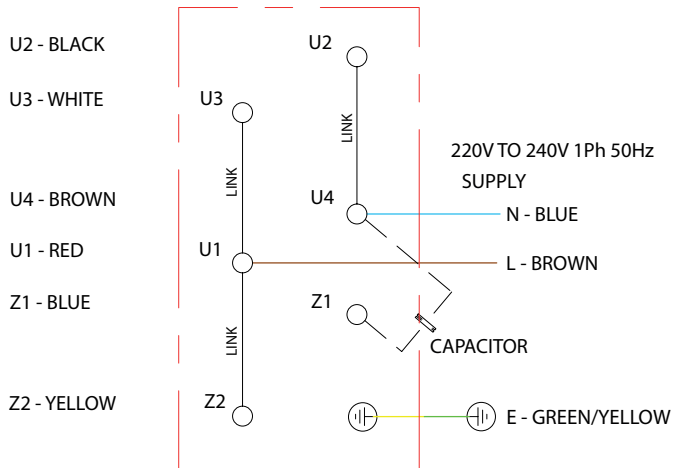

ANTI-CLOCKWISE ROTATION

5.4 Three Phase

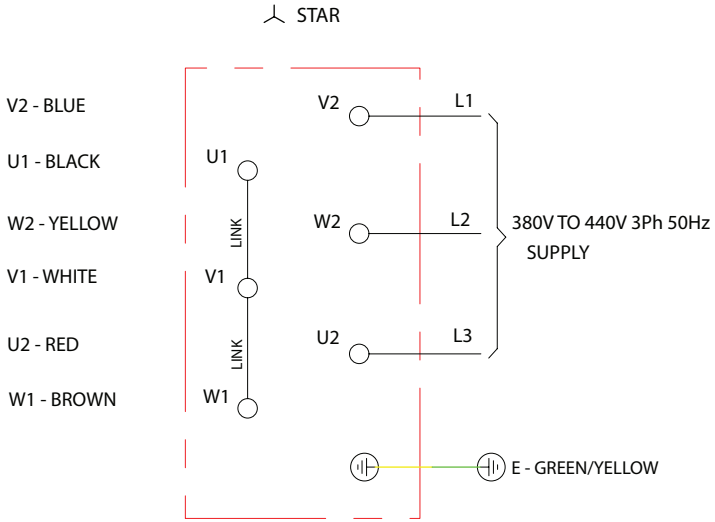

△ DELTA

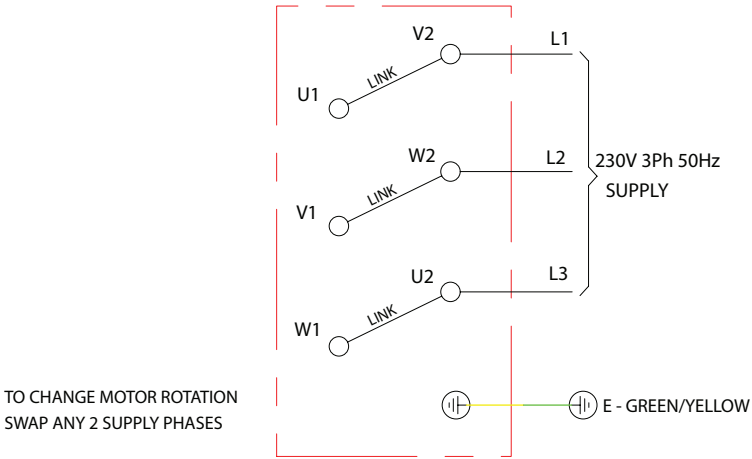

Replace the terminal cover and test run the fan unit, checking the rotation and fan currents.

5.5 Three Phase (motors with integral connection box)

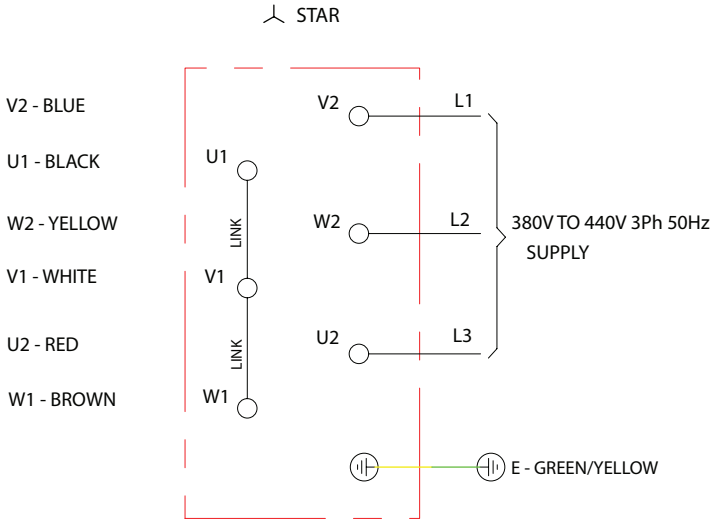

△ DELTA

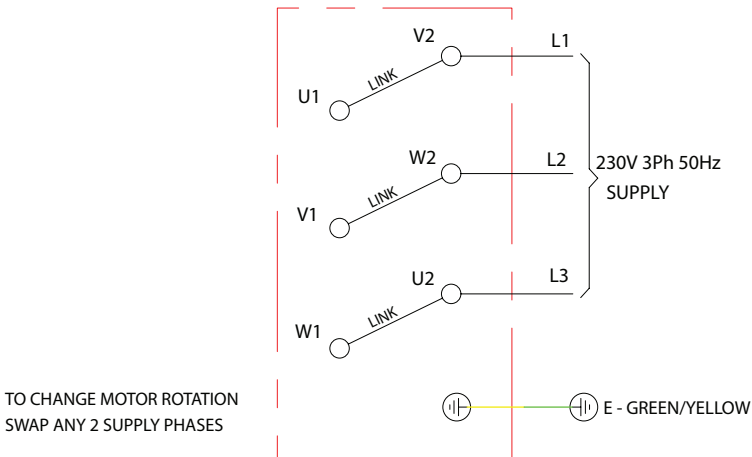

Replace the terminal cover and test run the fan unit, checking the rotation and fan currents.

5.6 Motors with flying leads with external terminal box

Single Phase

Form "A" Airflow Models Models

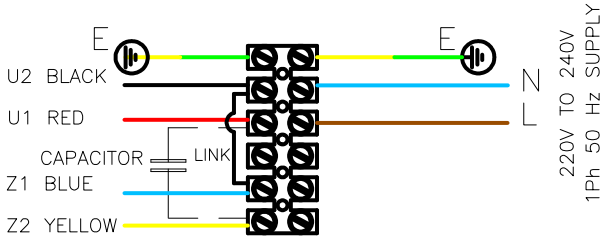

Anti-clockwise rotation (looking in the airflow direction)

To reverse the motor rotation interchange yellow & blue.
(Wires do not have markings)

Three Phase

DELTA (415V / 3Ph / 50Hz)

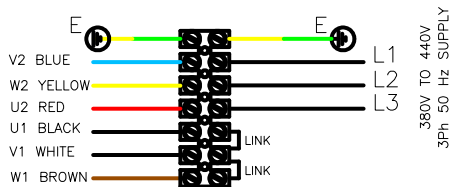

STAR (230V / 3Ph / 50Hz)

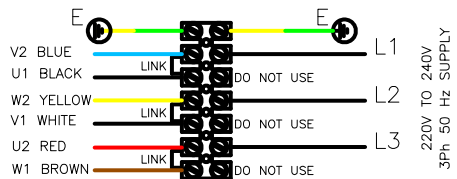

To reverse the motor rotation interchange any 2 supply phases
(wires do not have markings)

6. Dimensional Data

Model Number	A	B	C	ØD	E	F	G	H	J	Weight kg
HAF630	627	15	31.2	11.5	6	630	25	95	199	16
HAF710	704	15	31	11.5	8	709.5	25	95	198	18
HAF800	794	15	31	11.5	8	799.5	25	95	194	23

Dimensions in mm.

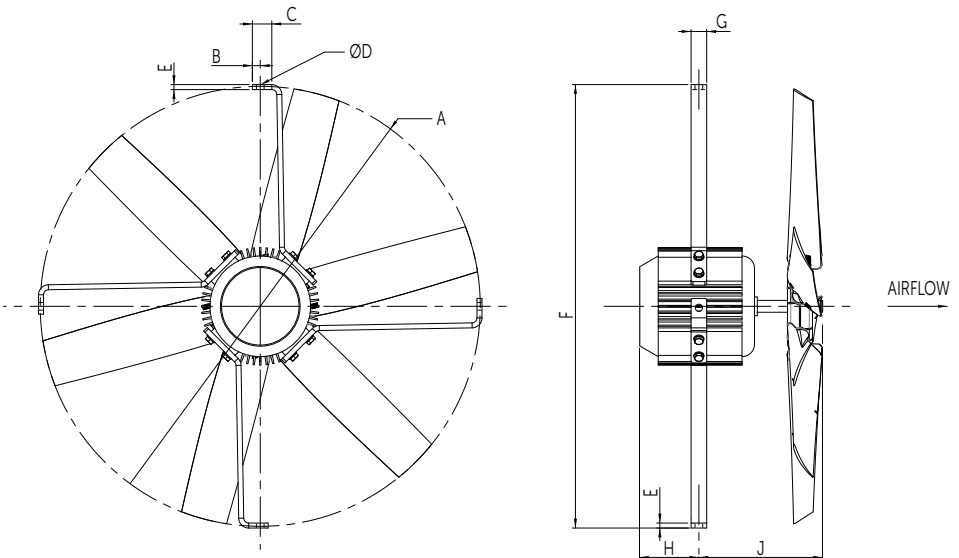

630mm unit will fit any 630-650mm tube or chimney.

710mm unit will fit any 710-730mm tube or chimney.

800mm unit will fit any 817-840mm tube or chimney.

You may need to use the included mounting hardware if the fan is not compatible with your existing mountings.

Guarantee

Hydor or its agents will, within a period of one year from the date of dispatch from their works, at its option, repair or replace any goods, which are proven to have defects as a result of defective materials or workmanship. The goods must be inspected by a Hydor official and if necessary returned, with a Returns Note Number, carriage paid, for further examination.

EG Agri Ltd

Hydor

Unit 8, Parkers Close, Downton Business Centre,
Downton, Salisbury, Wiltshire, SP5 3RB, UK

Tel: +44 (0) 1725 511422

Email: info@hydor.co.uk

Web: www.hydor.co.uk

Inst Issue 3: 03.23